



AX Control Company

www.axcontrol.com

Your Automation Supplier

PFXGP4303TAD

<http://www.axcontrol.com/automation/pro-face/gp-4000/PFXGP4303TAD>

Pro-face Xycom GP4000

PFXGP4303TAD

Pro-face Xycom GP-430xT GP430xT

Touch Screen Operator Interface 5.7 TFT Color LCD Display. Call Now!

1-800-991-7026

[**sales@axcontrol.com**](mailto:sales@axcontrol.com)

See Also:

<http://www.axcontrol.com/automation/pro-face/gp-4000>

<Panel Type/ Flat Mount : PFXGP4601TADR>

Installation with Installation Fasteners attached to the sides of the GP unit

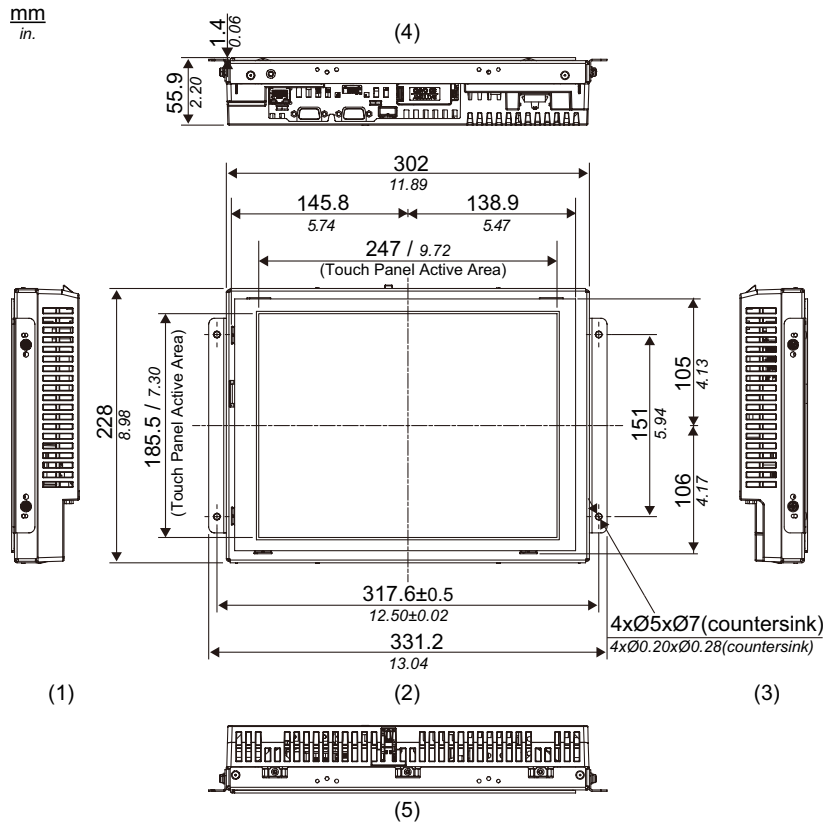

- 1 Right Side
- 2 Front
- 3 Left Side
- 4 Bottom
- 5 Top

<Panel Type/ Flat Mount : PFXGP4601TADR>

Dimensions with Cables

mm
in.

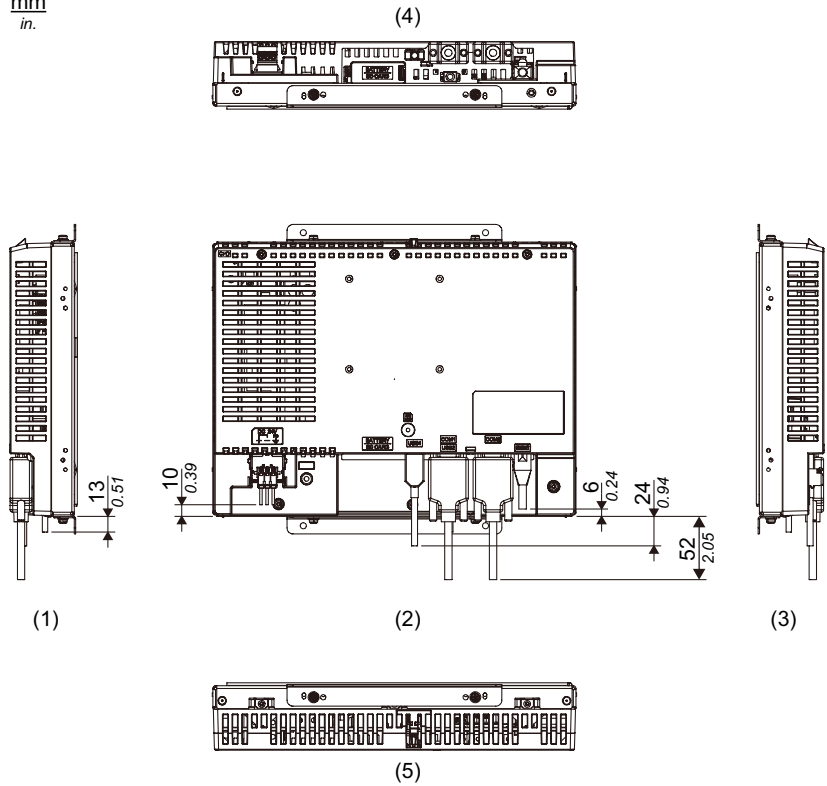

- 1 Right Side
- 2 Rear
- 3 Left Side
- 4 Bottom
- 5 Top

NOTE: All the above values are designed with cable bending in mind. The dimensions given here are representative values depending on the type of connection cable in use. Therefore, these values are intended for reference only.

<Resin BossType/ Standard Mount and Flat Mount : PFXGP4601TADR>

Installation with Installation Fasteners attached to the top and bottom surfaces of the GP unit

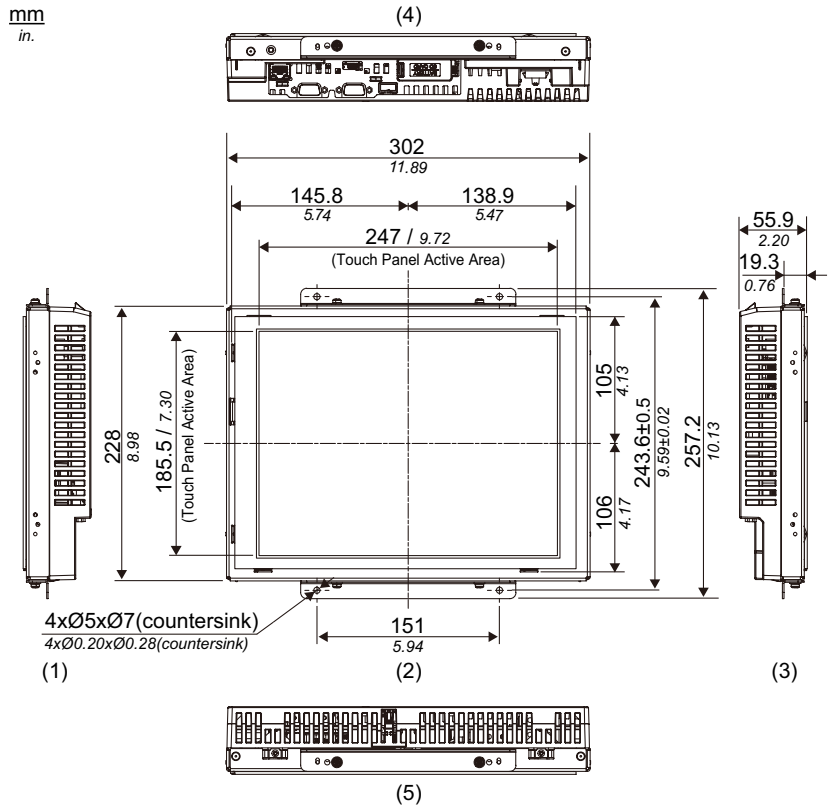

- 1 Right Side
- 2 Front
- 3 Left Side
- 4 Bottom
- 5 Top

<Resin Boss Type/ Standard Mount and Flat Mount : PFXGP4601TADR>
 Installation with Installation Fasteners attached to the sides of the GP unit

mm
in.

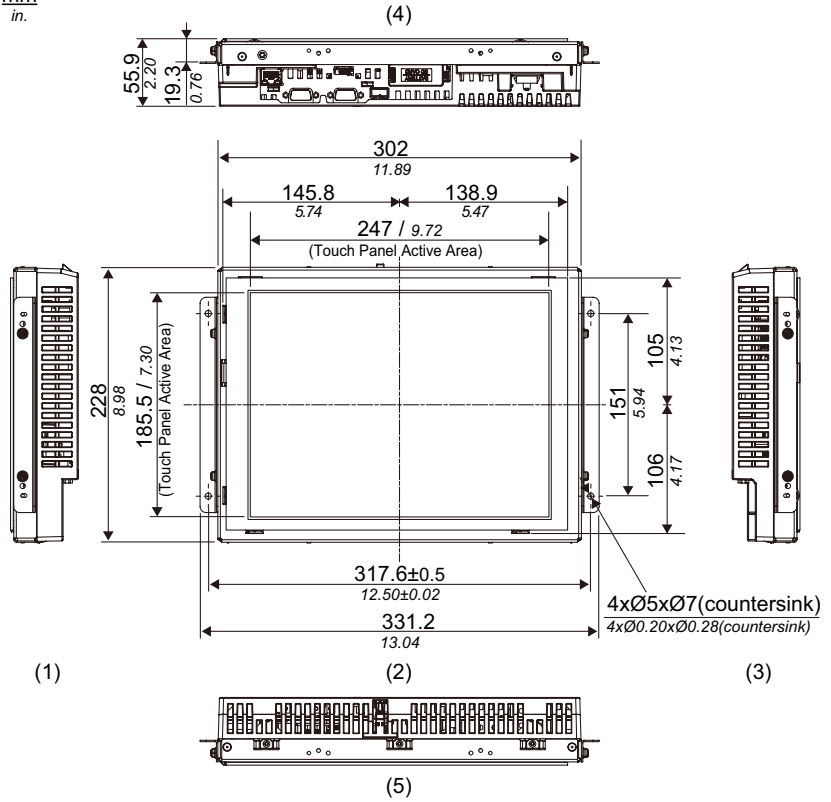

- 1 Right Side
- 2 Front
- 3 Left Side
- 4 Bottom
- 5 Top

<Resin Boss Type/ Standard Mount and Flat Mount : PFXGP4601TADR>

Dimensions with Cables

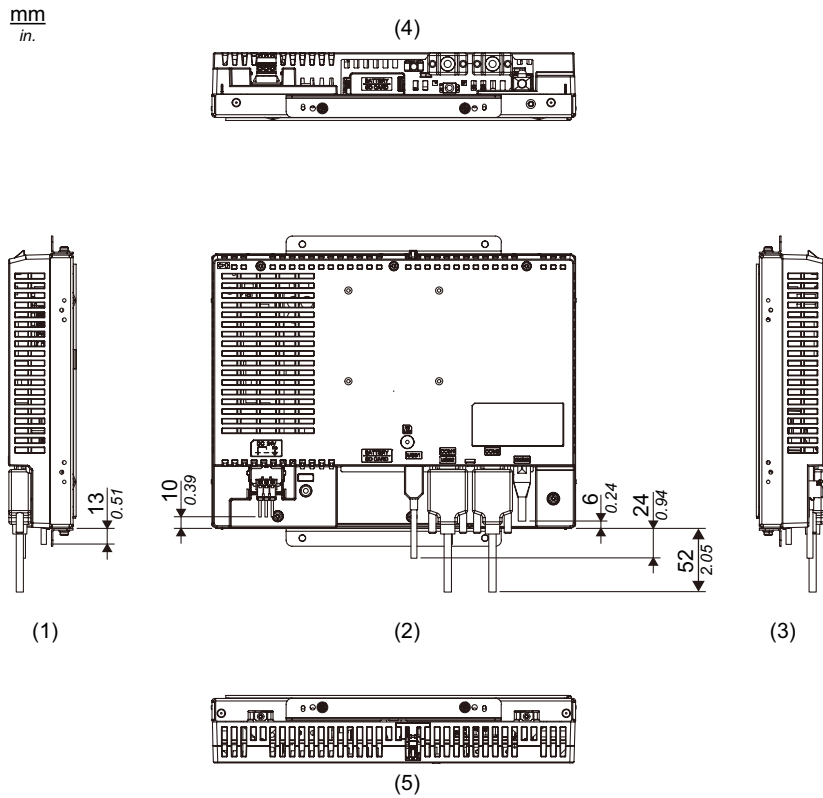

- 1 Right Side
- 2 Rear
- 3 Left Side
- 4 Bottom
- 5 Top

NOTE: All the above values are designed with cable bending in mind. The dimensions given here are representative values depending on the type of connection cable in use. Therefore, these values are intended for reference only.

7.7

Installation

Installation Method

Panel type	standard mount
	flat mount
Resin boss type	standard mount
	flat mount

Panel type: Weld the stud bolts to the panel, and then tighten the nuts to fasten the GP unit to the panel.

Resin boss type: Tighten the screws to attach the GP unit to the bosses of the resin boss-molded product.

Standard mount: The GP unit's screen is fixed within the inside of the panel or resin boss-molded product.

Flat mount: The GP unit's screen is fixed to the same surface of the panel or resin boss-molded product.

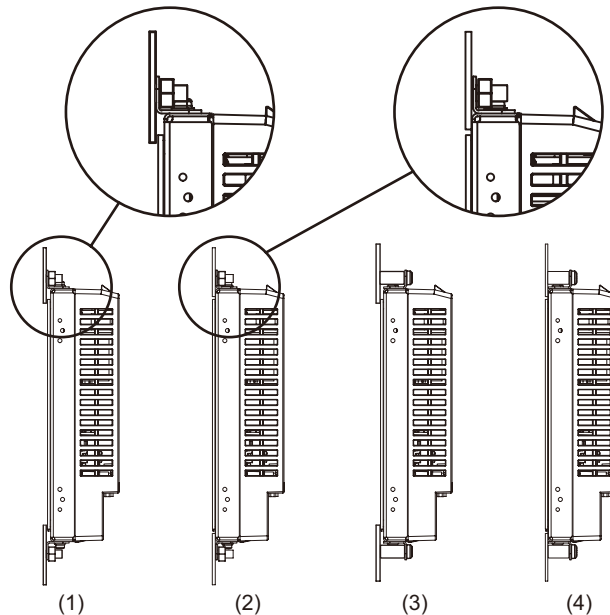

Installation diagrams (profile)

- 1) Panel type, standard mount
- 2) Panel type, flat mount
- 3) Resin boss type, standard mount
- 4) Resin boss type, flat mount

As shown in the figures, installation brackets can be attached at the top and bottom surfaces of the GP unit or on either side of the GP unit.

Installation Requirements

- Decide on the thickness of the enclosure wall, based on the level of strength required: For details, read chapter 3, "Panel Cut Dimensions" (see page 223).
- Even if panel thickness is within recommended range for "Panel Cut Dimensions", the panel could warp, depending on panel's material, size, and installation location of GP unit or other devices. To prevent panel warpage, the installation surface may need to be strengthened.
- Check that the installation panel or cabinet's surface is flat, in good condition and has no jagged edges.

Be sure that the surrounding air temperature and the ambient humidity are within their designated ranges. Surrounding air temperature:

0 to 55 °C (32 to 131 °F)

ambient humidity: 10 to 90%RH; wet bulb temperature: maximum 39 °C (102 °F).

When installing the GP unit in a cabinet or enclosure, the surrounding air temperature is the cabinet's or enclosure's internal temperature.

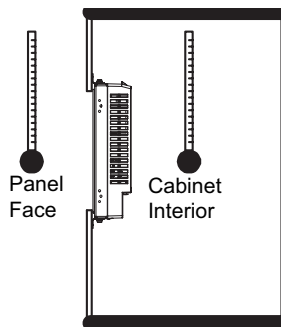

- Be sure that heat from surrounding equipment does not cause the GP unit to exceed its standard operating temperature.
- When installing the GP unit vertically, install the GP unit so that the power supply connector on the rear surface of the unit is at the top.

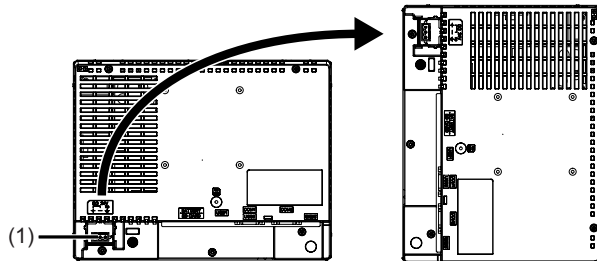

(1) Power Connector

- When installing the GP unit in a slanted position, the GP unit face should not incline more than 30°.

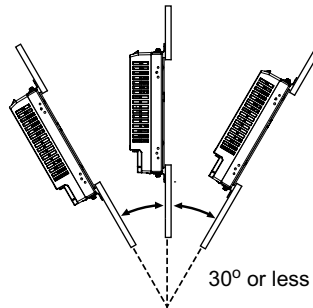

- When installing the GP unit in a slanted position with an incline more than 30°, the ambient temperature must not exceed 40 °C (104 °F). You may need to use forced air cooling (fan, A/C) to ensure the ambient operating temperature is 40°C or less (104 °F or less).
- For easier maintenance, operation and improved ventilation, install the GP unit at least 100 mm (3.94 in.) away from adjacent structures and other equipment as shown in the following illustration.

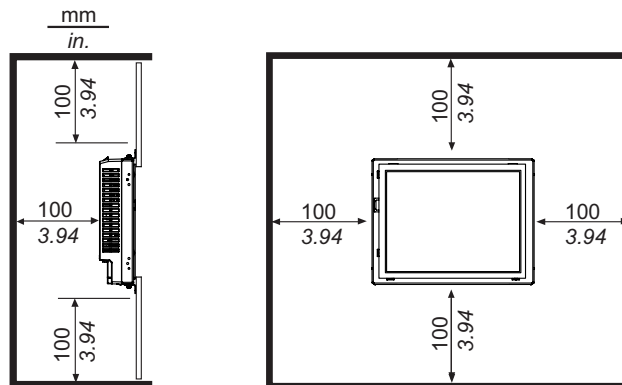

- The holes on the rear of the GP unit are not correspondent with VESA 75mm standards. Do not attach the GP unit to the commercial-type VESA arm.

Panel Cut Dimensions

- Standard mount

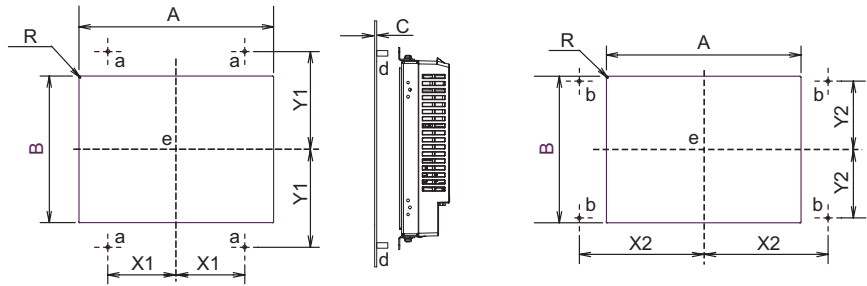

- Installation positions of stud bolts or positions of boss molds when attaching installation brackets at the top and bottom surfaces of the GP unit
- Installation positions of stud bolts or positions of boss molds when attaching installation brackets on either side of the GP unit
- 4-M4 x 10L stud bolts (no foreign material present on the base due to sparking or similar phenomena) or boss molds
- Center of the display area

	A	B	C		R
			Panel Type	Resin Boss Type	
PFXGP4301TADR	118.8mm (+0.5, -0mm) (4.68in.) [+0.02, -0in.]	90mm (+0.5, -0mm) (3.54in.) [+0.02, -0in.]	1.6mm (0.06in.) to 3.2mm (0.13in.)	2mm (0.08in.) or more	1mm (0.04in.) maximum
PFXGP4401TADR	155.3mm (+0.5, -0mm) (6.11in.) [+0.02, -0in.]	117.4mm (+0.5, -0mm) (4.62in.) [+0.02, -0in.]	SPCC (JIS G 3141) or SECC (JIS G 3313)		
PFXGP4501TADR	214.8mm (+0.5, -0mm) (8.46in.) [+0.02, -0in.]	162mm (+0.5, -0mm) (6.38in.) [+0.02, -0in.]	1.5mm (0.06in.) to 6mm (0.24in.) SUS304 (JIS G 4305)		
PFXGP4601TADR	249.6mm (+0.5, -0mm) (9.83in.) [+0.02, -0in.]	188.1mm (+0.5, -0mm) (7.41in.) [+0.02, -0in.]			

Note: If you are designing the panel with a material other than sheet metal, ensure that the material has sufficient strength.

Unit mm[in.]

	Attaching Installation Brackets on the Top and Bottom Surfaces of the GP Unit		Attaching Installation Brackets on the Sides of the GP Unit	
	X1	Y1	X2	Y2
PFXGP4301TADR	43 (±0.15) [1.69, (±0.01)]	69.5 (±0.15) [2.74, (±0.01)]	85.6 (±0.15) [3.37, (±0.01)]	43 (±0.15) [1.69, (±0.01)]
PFXGP4401TADR	43 (±0.15) [1.69, (±0.01)]	87.5 (±0.15) [3.45, (±0.01)]	109.8 (±0.15) [4.32, (±0.01)]	43 (±0.15) [1.69, (±0.01)]
PFXGP4501TADR	75.5 (±0.15) [2.97, (±0.01)]	108.55 (±0.15) [4.27, (±0.01)]	137.65 (±0.15) [5.42, (±0.01)]	75.5 (±0.15) [2.97, (±0.01)]
PFXGP4601TADR	75.5 (±0.15) [2.97, (±0.01)]	121.8 (±0.15) [4.80, (±0.01)]	158.8 (±0.15) [6.25, (±0.01)]	75.5 (±0.15) [2.97, (±0.01)]

Note: Note that the panel cut dimensions have been calculated with the display area, not the panel cut (A or B), as the reference.

● Flat mount

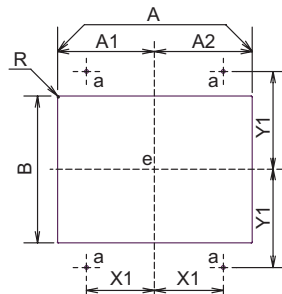

Rear panel (resin plate) surface

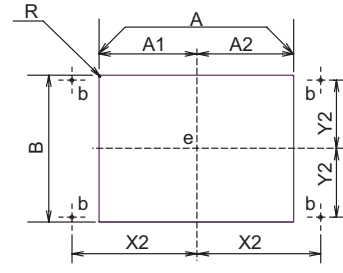
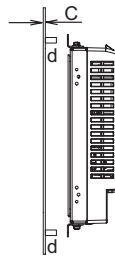

Rear panel (resin plate) surface

- a) Installation positions of stud bolts or positions of boss molds when attaching installation brackets at the top and bottom surfaces of the GP unit
- b) Installation positions of stud bolts or positions of boss molds when attaching installation brackets on either side of the GP unit
- d) 4-M4 x 10L stud bolts (no foreign material present on the base due to sparking or similar phenomena) or boss molds
- e) Center of the display area

	A		B	C		R
	A1	A2		Panel Type	Resin Boss Type	
PFXGP4301TADR	143mm (+0.5, -0mm) (5.63in.[+0.02, -0in.])		109mm (+0.5, -0mm) (4.29in. [+0.02, -0in.])	1.6 mm (0.06in.) SPCC (JIS G 3141) or SECC (JIS G 3313)	2 mm (0.08in.) maximum	1 mm (0.04in.) maximum
	70.5mm (+0.25, -0mm) (2.78in. [+0.01, -0in.])	72.5mm (+0.25, -0mm) (2.85in. [+0.01, -0in.])				
PFXGP4401TADR	174.5mm (+0.5, -0mm) (6.87in.[+0.02, -0in.])		134.2mm (+0.5, -0mm) (5.28in. [+0.02, -0in.])			
	86.3mm (+0.25, -0mm) (3.4in. [+0.01, -0in.])	88.2mm (+0.25, -0mm) (3.47in. [+0.01, -0in.])				
PFXGP4501TADR	241mm (+0.5, -0mm) (9.49in.[+0.02, -0in.])		188mm (+0.5, -0mm) (7.4in. [+0.02, -0in.])			
	119.2mm (+0.25, -0mm) (4.69in. [+0.01, -0in.])	121.8mm (+0.25, -0mm) (4.8in. [+0.01, -0in.])				
PFXGP4601TADR	289.4mm (+0.5, -0mm) (11.39in.[+0.02, -0in.])		214.4mm (+0.5, -0mm) (8.44in. [+0.02, -0in.])			
	142.4mm (+0.25, -0mm) (5.61in. [+0.01, -0in.])	147mm (+0.25, -0mm) (5.79in. [+0.01, -0in.])				

Note: If you are designing the panel with a material other than sheet metal, ensure that the material has sufficient strength.