



**MD65 AC Drive  
User Manual  
Version 2.0**

---

Instruction Manual D2-3519-2

---

**Rockwell**  
**Automation**

The information in this manual is subject to change without notice.

Throughout this manual, the following notes are used to alert you to safety considerations:



**ATTENTION:** Identifies information about practices or circumstances that can lead to personal injury or death, property damage, or economic loss.

**Important:** Identifies information that is critical for successful application and understanding of the product.

The thick black bar shown on the outside margin of this page is used throughout this manual to signify new or revised text or figures.



**ATTENTION:** Only qualified personnel familiar with the construction and operation of this equipment and the hazards involved should install, adjust, operate, or service this equipment. Read and understand this document in its entirety before proceeding. Failure to observe this precaution could result in severe bodily injury or loss of life.

**ATTENTION:** The drive contains high voltage capacitors that take time to discharge after removal of mains supply. Before working on the drive, ensure isolation of mains supply from line inputs [R, S, T (L1, L2, L3)]. Wait three (3) minutes for capacitors to discharge to safe voltage levels. Darkened display LEDs is not an indication that capacitors have discharged to safe voltage levels. Failure to observe this precaution could result in severe bodily injury or loss of life.

**ATTENTION:** The drive can operate at and maintain zero speed. The user is responsible for assuring safe conditions for operating personnel by providing suitable guards, audible or visual alarms, or other devices to indicate that the drive is operating, or may operate, at or near zero speed. Failure to observe this precaution could result in severe bodily injury or loss of life.

**ATTENTION:** The drive contains ESD- (Electrostatic Discharge) sensitive parts and assemblies. Static control precautions are required when installing, testing, servicing, or repairing the drive. Erratic machine operation and damage to, or destruction of, equipment can result if this precaution is not followed. Failure to observe this precaution can result in bodily injury.

**ATTENTION:** The user must provide an external, hardwired emergency stop circuit outside of the drive circuitry. This circuitry must disable the system in case of improper operation. Uncontrolled machine operation may result if this precaution is not followed. Failure to observe this precaution could result in bodily injury.

**ATTENTION:** The user is responsible for conforming with all applicable local and national codes. Failure to observe this precaution could result in damage to, or destruction of, the equipment.

**ATTENTION:** An incorrectly applied or installed drive can result in component damage or reduction in product life. Wiring or application errors, such as undersizing the motor, incorrect or inadequate AC supply, or excessive ambient temperatures may result in malfunction of the system.

MD65, VS Utilities, and Reliance are trademarks of Rockwell Automation.

©2004 Rockwell Automation. All rights reserved.

# CONTENTS

---

<b>Chapter 1 Introduction</b>	
1.1 Getting Assistance from Reliance Electric.....	1-1
<b>Chapter 2 About the MD65 Drive</b>	
2.1 Identifying the Drive by Model Number.....	2-1
2.2 MD65 Drive Ratings, Model Numbers, and Frame Sizes .....	2-2
2.3 Kits and Accessories .....	2-3
2.4 Storage Guidelines .....	2-4
<b>Chapter 3 Mounting the Drive</b>	
3.1 General Requirements for the Installation Site .....	3-1
3.1.1 Operating Conditions.....	3-2
3.1.2 Minimum Mounting Clearances .....	3-2
3.1.3 Mounting Dimensions for the MD65 Drive .....	3-3
3.2 Mounting the Drive.....	3-6
3.2.1 Protecting the Drive from Debris .....	3-6
<b>Chapter 4 Grounding the Drive</b>	
4.1 RFI Filter Grounding .....	4-2
<b>Chapter 5 Installing Power Wiring</b>	
5.1 Opening the Cover.....	5-1
5.2 Verifying Drive AC Input Ratings Match Available Power .....	5-2
5.2.1 Ungrounded Distribution Systems .....	5-2
5.2.2 Input Power Conditioning .....	5-4
5.3 Power Wiring Specifications .....	5-4
5.4 Power Terminal Block Connections.....	5-5
5.5 Fuses and Circuit Breakers .....	5-6
5.6 Motor Cable Types Acceptable for 200-600 Volt Installations .....	5-8
5.7 Reflected Wave Protection .....	5-10
5.8 Output Disconnect .....	5-10
<b>Chapter 6 Installing Control Wiring</b>	
6.1 Stop Circuit Requirements.....	6-1
6.2 Motor Start/Stop Precautions.....	6-2
6.3 I/O Wiring Recommendations.....	6-3
6.3.1 Maximum Control Wire Length Recommendations .....	6-3
6.4 Wiring the Control Terminal Block .....	6-4
6.4.1 I/O Wiring Examples.....	6-6

6.4.2 Typical Multiple Drive Connection Examples.....	6-9
6.5 Start and Speed Reference Control.....	6-10
6.6 Accel/Decel Selection .....	6-11

## Chapter 7 Completing the Installation

7.1 Checking the Installation Before Applying Power to the Drive .....	7-1
7.2 Powering Up After Installation is Complete.....	7-2

## Chapter 8 Using the Integral Keypad to Program and Control the Drive

8.1 Keypad Components .....	8-1
8.1.1 Display Description .....	8-2
8.1.2 LED Descriptions .....	8-2
8.1.3 Key Descriptions.....	8-3
8.2 About Parameters .....	8-4
8.3 How Parameters are Organized .....	8-4
8.4 Viewing and Adjusting Basic (P) and Advanced (A) Parameters .....	8-5
8.5 Viewing the Display (d) Parameters.....	8-6

## Chapter 9 Parameter Descriptions

9.1 Basic Program Group Parameters.....	9-2
9.2 Advanced Group Parameters .....	9-8
9.3 Display Group Parameters.....	9-46

## Chapter 10 Troubleshooting the Drive

10.1 Fault Codes.....	10-1
10.1.1 Manually Clearing Faults .....	10-2
10.1.2 Automatically Clearing Faults (Auto Restart Feature) .....	10-2
10.2 Troubleshooting Tables .....	10-7
10.2.1 Problem: Drive Does Not Start From Terminal Block Start or Run Inputs .....	10-7
10.2.2 Problem: Drive Does Not Start From Integral Keypad.....	10-8
10.2.3 Problem: Drive Does Not Respond to Changes in Speed Command .....	10-8
10.2.4 Problem: Motor Does Not Start.....	10-9
10.2.5 Problem: Motor and/or Drive Will Not Accelerate to Commanded Speed .....	10-10
10.2.6 Problem: Motor Operation is Unstable.....	10-10
10.2.7 Problem: Drive Will Not Reverse Motor Direction .....	10-11
10.2.8 Problem: Drive Does Not Power Up .....	10-11

## Appendix A Technical Specifications..... A-1

<b>Appendix B</b>	Record of User Settings .....	B-1
<b>Appendix C</b>	Parameters Cross-Referenced by Name .....	C-1
<b>Appendix D</b>	CE Conformance Requirements .....	D-1
<b>Appendix E</b>	Accessories.....	E-1
<b>Appendix F</b>	RS485 (MDI) Protocol.....	F-1
<b>Appendix G</b>	RJ45 Splitter Cable .....	G-1
<b>Appendix H</b>	StepLogic™, Basic Logic and Time/Counter Functions .....	H-1
<b>Appendix I</b>	PID Setup.....	I-1
<b>Index</b>	Index-1	



# List of Figures

Figure 2.1 – Identifying the Drive by Model Number.....	2-1
Figure 3.1 – Minimum Mounting Clearances .....	3-2
Figure 3.2 – Drive Dimensions and Weights.....	3-3
Figure 3.3 – Drive Dimensions - NEMA 1/IP30 Kit Without Communication Option .....	3-4
Figure 3.4 – Drive Dimensions - NEMA 1/IP30 Kit With Communication Option .....	3-5
Figure 4.1 – Typical Grounding.....	4-1
Figure 5.1 – Opening the Cover.....	5-1
Figure 5.2 – Removing the Finger Guard .....	5-2
Figure 5.3 – Removing the Jumper.....	5-3
Figure 5.4 – Phase-to-Ground MOV Removal.....	5-3
Figure 5.5 – Power Terminal Block Connections.....	5-5
Figure 6.1 – Control Terminal Block .....	6-4
Figure 6.2 – Override Priority for the Speed Reference Command .....	6-10
Figure 6.3 – Accel/Decel Selection .....	6-11
Figure 8.1 – Integral Keypad .....	8-1
Figure 9.1 – Accel Time 1 (P039) .....	9-6
Figure 9.2 – Decel Time 1 (P040).....	9-7
Figure 9.3 – Accel Time 2 (A067) .....	9-18
Figure 9.4 – Decel Time 2 (A068).....	9-19
Figure 9.5 – DC Brake Level (A081).....	9-21
Figure 9.6 – S Curve % (A083) Example.....	9-22
Figure 9.7 – Boost Select (A084).....	9-23
Figure 9.8 – Start Boost (A085) .....	9-24
Figure 9.9 – Motor OL Select (A090).....	9-25
Figure 9.10 – Derating Guidelines Based on PWM Frequency (A091) Selection .....	9-26
Figure 9.11 – Anlg In 0-10V Lo (A110) .....	9-32
Figure 9.12 – Skip Freq Band (A120).....	9-35
Figure 9.13 – Digit Settings.....	9-43
Figure 9.14 – EM BRK Off Delay .....	9-44
Figure 9.15 – Drive Status (d006) Bit Definitions.....	9-47
Figure 9.16 – Control Source (d012) Bit Definitions .....	9-48
Figure 9.17 – Contrl In Status (d013) Bit Definitions.....	9-49
Figure 9.18 – Dig In Status (d014) Bit Definitions.....	9-49
Figure 9.19 – Comm Status (d015) Bit Definitions.....	9-50





# List of Tables

Table 2.1 – Drive Ratings, Model Numbers, and Frame Sizes.....	2-2
Table 2.2 – Standard Kits and Accessories .....	2-3
Table 3.1 – Ambient Operating Temperatures and Mounting Clearances.....	3-2
Table 3.2 – Mounting Specifications .....	3-6
Table 5.1 – Corrective Actions for Input Power Conditions .....	5-4
Table 5.2 – Power Wiring Specifications .....	5-4
Table 5.3 – Power Terminal Block Specifications.....	5-5
Table 5.4 – Drive, Fuse, and Circuit Breaker Ratings.....	5-7
Table 5.5 – Shielded Motor Cable Types Acceptable for 200-600 Volt Installations.....	5-9
Table 5.6 – Maximum Cable Length Recommendation.....	5-10
Table 6.1 – Recommended Control and Signal Wire.....	6-3
Table 6.2 – I/O Terminal Block Specifications .....	6-3
Table 6.3 – Control Terminal Definitions and Related Parameters.....	6-5
Table 6.4 – Typical Multiple Drive Connection Examples.....	6-9
Table 8.1 – LED Descriptions .....	8-2
Table 8.2 – Key Descriptions .....	8-3
Table 8.3 – Viewing and Adjusting Basic (P) and Advanced (A) Parameters .....	8-5
Table 8.4 – Viewing the Display (d) Parameters.....	8-6
Table 9.1 – Trip Points for Digital Output Relay.....	9-13
Table 9.2 – On/Off Points for the Opto Outputs.....	9-16
Table 9.3 – A064 Options .....	9-17
Table 9.4 – Analog Output Signal Mode Selections .....	9-17
Table 9.5 – Selecting the Reference Source Using Presets.....	9-20
Table 9.6 – Related Parameters for Stp Logic Parameters (A140-A147) .....	9-41
Table 10.1 – Fault Descriptions and Corrective Actions.....	10-3
Table 10.2 – Problem: Drive Does Not Start From Terminal Block Start or Run Inputs.....	10-7
Table 10.3 – Problem: Drive Does Not Start From Integral Keypad.....	10-8
Table 10.4 – Problem: Drive Does Not Respond to Changes in Speed Command.....	10-8
Table 10.5 – Problem: Motor and/or Drive Will Not Accelerate to Commanded Speed.....	10-10
Table 10.6 – Problem: Motor Operation is Unstable.....	10-10
Table 10.7 – Problem: Drive Will Not Reverse Motor Direction.....	10-11



# CHAPTER 1

---

## Introduction

This manual is intended for qualified electrical personnel familiar with installing, programming, and maintaining AC drives.

This manual contains information on:

- Installing and wiring the MD65 drive
- Programming the drive
- Troubleshooting the drive

The latest version of this manual is available from <http://www.theautomationbookstore.com> or [http://www.reliance.com/docs\\_onl/online\\_stdrv.htm](http://www.reliance.com/docs_onl/online_stdrv.htm).

### 1.1 Getting Assistance from Reliance Electric

If you have any questions or problems with the products described in this instruction manual, contact your local Reliance Electric sales office.

For technical assistance, call 1-864-284-5053. Before calling, please review the troubleshooting section of this manual and check the Reliance Electric Standard Drives website for additional information. When you call this number, you will be asked for the drive model number or catalog number and this instruction manual number.



# CHAPTER 2

## About the MD65 Drive

This chapter provides general information about the MD65 AC drive, including how to identify the drive.

### 2.1 Identifying the Drive by Model Number

Each drive can be identified by its model number, as shown in figure 2.1. The model number is on the shipping label and the drive nameplate. The model number includes the drive and any options. Drive model numbers are provided in table 2.1.

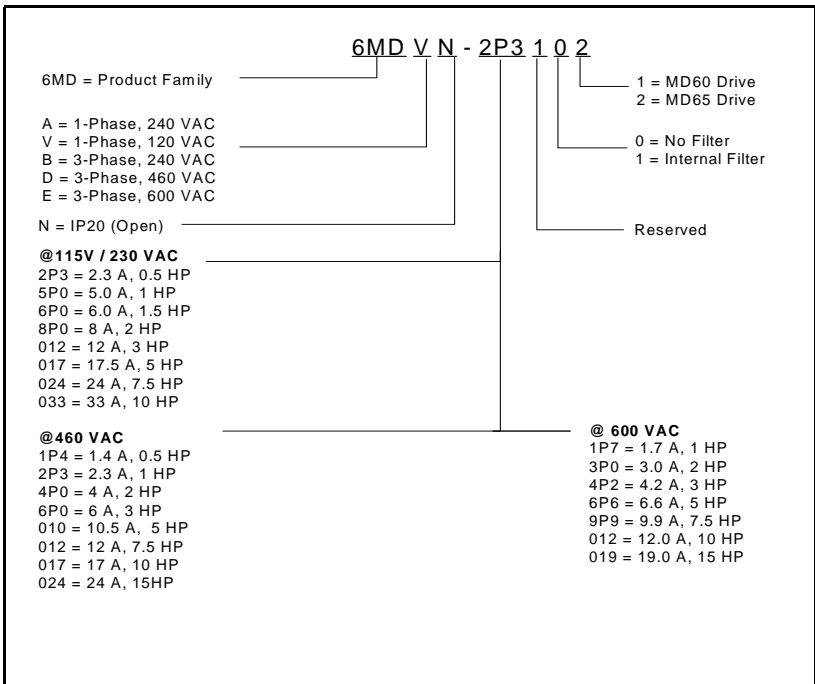

Figure 2.1 – Identifying the Drive by Model Number

## 2.2 MD65 Drive Ratings, Model Numbers, and Frame Sizes

Similar MD65 drive sizes are grouped into frame sizes to simplify re-ordering and dimensioning. Refer to figures 3.2 through 3.4 for the dimensions of each frame size.

Table 2.1 provides MD65 drive ratings, model numbers, and frame sizes.

Table 2.1 – Drive Ratings, Model Numbers, and Frame Sizes

Drive Ratings				Model Number	Frame Size
Input Voltage	kW	HP	Output Current		
120V 50/60 Hz 1-Phase No Filter	0.4	0.5	2.3A	6MDVN-2P3102	B
	0.75	1.0	5.0A	6MDVN-5P0102	B
	1.1	1.5	6.0A	6MDVN-6P0102	B
240V 50/60 Hz 1-Phase With Integral "S Type" EMC Filter	0.4	0.5	2.3A	6MDAN-2P3112	B
	0.75	1.0	5.0A	6MDAN-5P0112	B
	1.5	2.0	8.0A	6MDAN-8P0112	B
	2.2	3.0	12.0A	6MDAN-012112	C
240V 50/60 Hz 1-Phase No Filter	0.4	0.5	2.3 A	6MDAN-2P3102	B
	0.75	1.0	5.0 A	6MDAN-5P0102	B
	1.5	2.0	8.0 A	6MDAN-8P0102	B
	2.2	3.0	12.0 A	6MDAN-012102	C
240V 50/60 Hz 3-Phase No Filter	0.4	0.5	2.3 A	6MDBN-2P3102	B
	0.75	1.0	5.0 A	6MDBN-5P0102	B
	1.5	2.0	8.0 A	6MDBN-8P0102	B
	2.2	3.0	12.0 A	6MDBN-012102	B
	3.7	5.0	17.5 A	6MDBN-017102	B
	5.5	7.5	24.0 A	6MDBN-024102	C
480V 50/60 Hz 3-Phase No Filter	0.4	0.5	1.4 A	6MDDN-1P4102	B
	0.75	1.0	2.3 A	6MDDN-2P3102	B
	1.5	2.0	4.0 A	6MDDN-4P0102	B
	2.2	3.0	6.0 A	6MDDN-6P0102	B
	4.0	5.0	10.5 A	6MDDN-010102	B
	5.5	7.5	12.0 A	6MDDN-012102	C
	7.5	10.0	17.0 A	6MDDN-017102	C
	11	15.0	24.0 A	6MDDN-024102	C

Table 2.1 – Drive Ratings, Model Numbers, and Frame Sizes (Continued)

Drive Ratings				Model Number	Frame Size
Input Voltage	kW	HP	Output Current		
600V 50/60 Hz 3-Phase No Filter	0.75	1.0	1.7 A	6MDEN-1P7102	B
	1.5	2.0	3.0 A	6MDEN-3P0102	B
	2.2	3.0	4.2 A	6MDEN-4P2102	B
	4.0	5.0	6.6 A	6MDEN-6P6102	B
	5.5	7.5	9.9 A	6MDEN-9P9102	C
	7.5	10.0	12.2 A	6MDEN-012102	C
	11	15.0	19.0 A	6MDEN-019102	C

## 2.3 Kits and Accessories

Table 2.2 lists kits and accessories for the MD65 drive. Contact Reliance Electric for more information about these kits.

Table 2.2 – Standard Kits and Accessories

Kit Description	Model Number
DeviceNet Communication Module (requires a Communication Module Cover, purchased separately)	MDCOMM-DNET
Communication Module Cover, B-Frame Drive	6MD-COMMCVR-B
Communication Module Cover, C-Frame Drive	6MD-COMMCVR-C
Serial Converter Module (RS485 to RS232; includes Serial Converter and cable)	MDCOMM-232
VS Utilities Software CD	RECOMM-VSUTIL
NEMA 1/IP30 Kit, B-Frame drive (includes conduit box with mounting screws and plastic top panel)	6MD-NM1B
NEMA 1/IP30 Kit, C-Frame drive (includes conduit box with mounting screws and plastic top panel)	6MD-NM1C
NEMA 1/IP30 Kit for Communication Option, B-Frame Drive (includes communication option conduit box with mounting screws and plastic top panel)	6MD-NM1COMMB
NEMA 1/IP30 Kit for Communication Option, C-Frame Drive (includes communication option conduit box with mounting screws and plastic top panel)	6MD-NM1COMMC
Remote Panel-Mount OIM (digital speed control, CopyCat capable, IP66 (NEMA 4X/12 indoor use only), includes 2.9 meter cable).	MD4LCD-PNL

Table 2.2 – Standard Kits and Accessories (Continued)

Kit Description	Model Number
Remote Handheld OIM (digital speed control, full numeric keypad, CopyCat capable, IP30 (NEMA Type 1); includes 1.0 meter cable; panel-mount with optional Bezel Kit.	MD1CC
Bezel Kit (panel mount for Remote Handheld OIM)	MDBZL-N1
OIM Cable (1.0 meter OIM-to-RJ45 cable)	MDCBL-CC1
OIM Cable (2.9 meter OIM-to-RJ45 cable)	MDCBL-CC3
RJ45 Cable (2.0 meter RJ45-to-RJ45 cable, male-to-male connectors)	MDCBL-RJ45
Serial Cable (2.0 meter serial cable with a locking low profile connector to connect to the serial converter and a 9-pin sub-miniature D female connector to connect to a computer)	RECBL-SFC
Dynamic Brake Resistors	AK-R2-xxx
RJ45 Splitter Cable (RJ45 one-to-two port splitter cable)	AK-U0-RJ45-SCI
Terminating Resistors (RJ45 120 Ohm resistors; 2 pieces)	AK-U0-RJ45-TRI
Terminal Block (RJ45 two-position terminal block; 5 pieces)	AK-U0-TB2P

## 2.4 Storage Guidelines

If you need to store the drive, follow these recommendations to prolong drive life and performance:

- Store the drive within an ambient temperature range of -40° to +85° C.
- Store the drive within a relative humidity range of 0% to 95%, non-condensing.
- Do not expose the drive to a corrosive atmosphere.



## Mounting the Drive

This chapter provides information that must be considered when planning an MD65 drive installation and provides drive mounting information and installation site requirements.



**ATTENTION:** Only qualified electrical personnel familiar with the construction and operation of this equipment and the hazards involved should install, adjust, operate, or service this equipment. Read and understand this manual and other applicable manuals in their entirety before proceeding. Failure to observe this precaution could result in severe bodily injury or loss of life.

**ATTENTION:** Use of power correction capacitors on the output of the drive can result in erratic operation of the motor, nuisance tripping, and/or permanent damage to the drive. Remove power correction capacitors before proceeding. Failure to observe this precaution could result in damage to, or destruction of, the equipment.

**ATTENTION:** The user is responsible for conforming with all applicable local, national, and international codes. Failure to observe this precaution could result in damage to, or destruction of, the equipment.

### 3.1 General Requirements for the Installation Site

It is important to properly plan before installing an MD65 drive to ensure that the drive's environment and operating conditions are satisfactory.

The area behind the drive must be kept clear of all control and power wiring. Power connections may create electromagnetic fields that may interfere with control wiring or components when run in close proximity to the drive.

Read the recommendations in the following sections before continuing with the drive installation.

### 3.1.1 Operating Conditions

Before deciding on an installation site, consider the following guidelines:

- Protect the cooling fan by avoiding dust or metallic particles.
- Do not expose the drive to a corrosive atmosphere.
- Protect the drive from moisture and direct sunlight.
- Verify that the drive location will meet the environmental conditions specified in table 3.1.

Table 3.1 – Ambient Operating Temperatures and Mounting Clearances

Ambient Temperature		Enclosure Rating	Minimum Mounting Clearances
Minimum	Maximum		
-10°C (14°F)	40°C (104°F)	IP20/Open Type	Use Mounting Option A (figure 3.1)
		IP30/NEMA 1/UL Type 1 <sup>1</sup>	Use Mounting Option B (figure 3.1)
	50°C (122°F)	IP20/Open Type	Use Mounting Option B (figure 3.1)

<sup>1</sup> Rating requires installation of the MD65 NEMA 1/IP30 Kit.

### 3.1.2 Minimum Mounting Clearances

Refer to figure 3.1 for the minimum mounting clearances. Refer to section 3.1.3 for drive mounting dimensions.

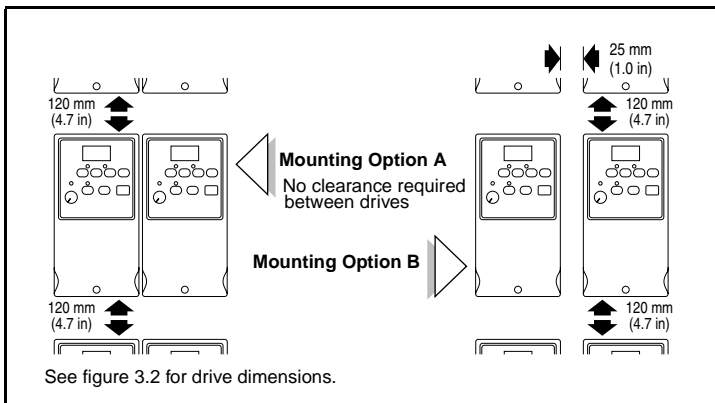

Figure 3.1 – Minimum Mounting Clearances

### 3.1.3 Mounting Dimensions for the MD65 Drive

Overall dimensions and weights are illustrated in figures 3.2, 3.3, and 3.4 as an aid to calculating the total area required by the MD65 drive. Dimensions are in millimeters and (inches). Weights are in kilograms and (pounds). See table 2.1 for drive ratings by frame.

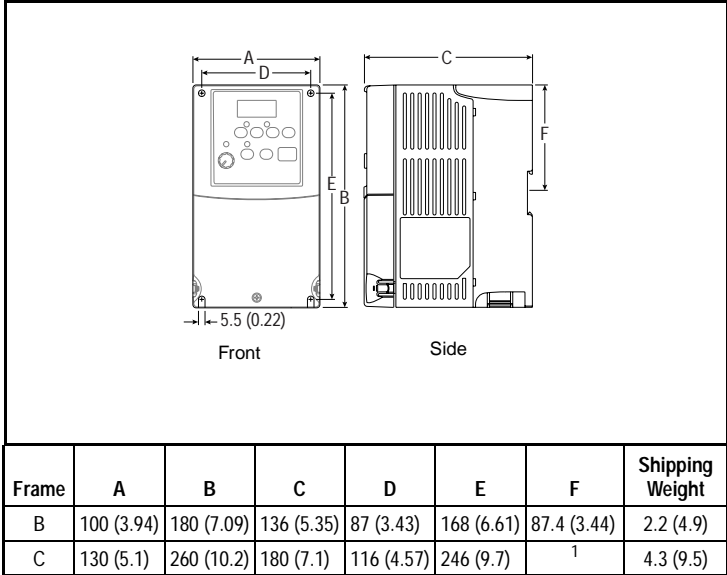
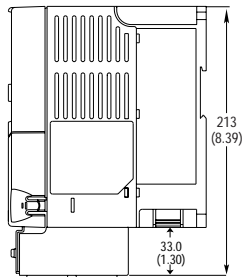
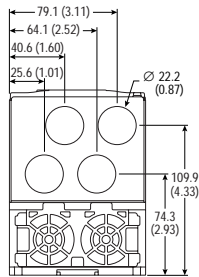

Figure 3.2 – Drive Dimensions and Weights

<sup>1</sup> C Frame does not have DIN rail mounting.



Side View



Bottom View

Frame B

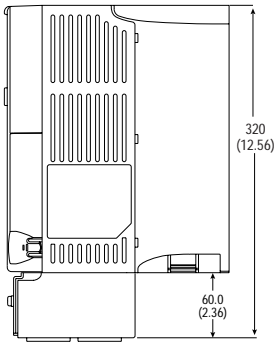

Side View

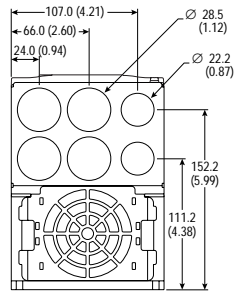

Bottom View

Frame C

All dimensions are in mm (in).

Figure 3.3 – Drive Dimensions - NEMA 1/IP30 Kit Without Communication Option

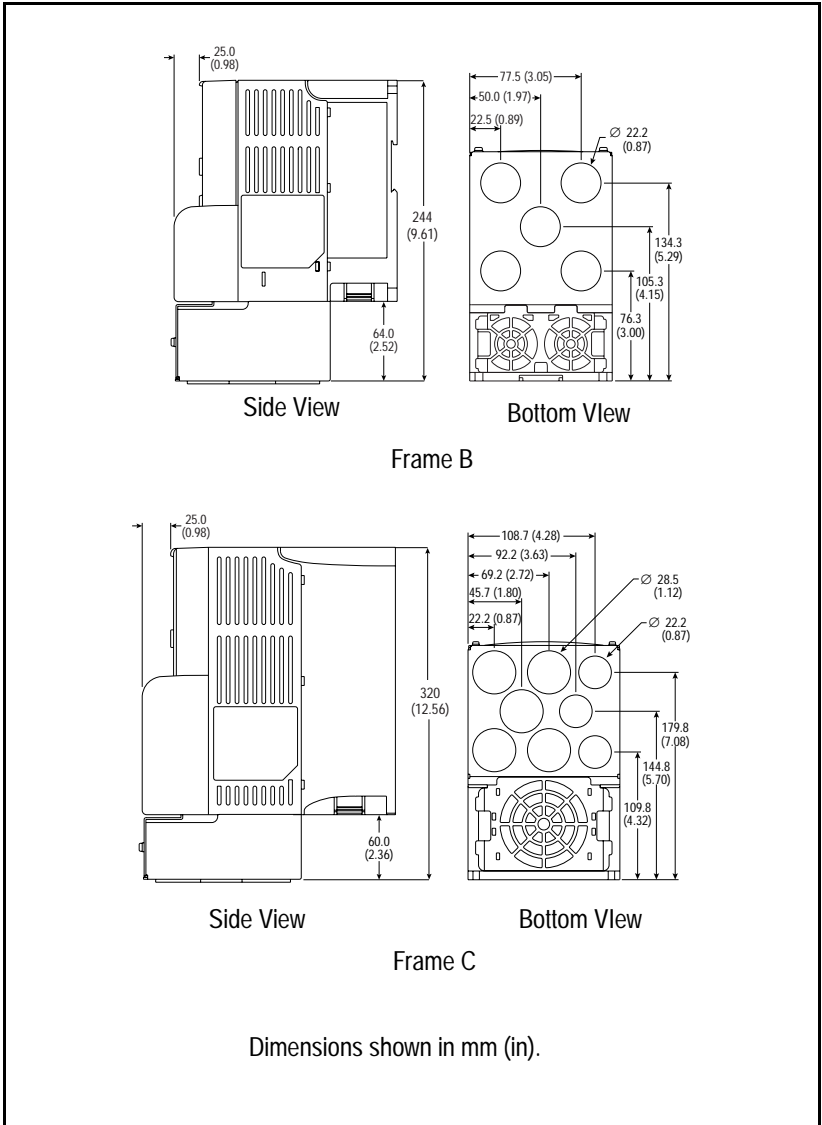

Figure 3.4 – Drive Dimensions - NEMA 1/IP30 Kit With Communication Option

## 3.2 Mounting the Drive

Mount the drive upright on a flat, vertical, and level surface.

Table 3.2 – Mounting Specifications

Frame	Screw Size	Screw Torque	-OR-	DIN Rail
B	M4 (#8-32)	1.56-1.96 N-m (14-17 in-lb)		35 mm
C	M5 (#10-24)	2.45-2.94 N-m (22-26 in-lb)		-

### 3.2.1 Protecting the Drive from Debris

A plastic top panel is included with the drive. Install the panel to prevent debris from falling through the vent of the drive housing during installation. Remove the panel for IP20/Open Type applications.

# CHAPTER 4

## Grounding the Drive



**ATTENTION:** The following information is merely a guide for proper installation. Rockwell Automation cannot assume responsibility for the compliance or the noncompliance to any code, national, local or otherwise for the proper installation of this drive or associated equipment. A hazard of personal injury and/or equipment damage exists if codes are ignored during installation.

The drive Safety Ground -  $\oplus$  (PE) must be connected to system ground. Ground impedance must conform to the requirements of national and local industrial safety regulations and/or electrical codes. The integrity of all ground connections should be periodically checked.

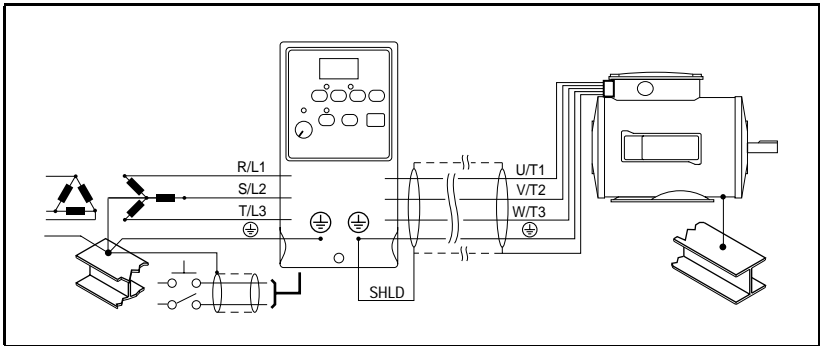

Figure 4.1 – Typical Grounding

### Ground Fault Monitoring

If a system ground fault monitor is to be used, only Type B (adjustable) devices should be used to avoid nuisance tripping.

## Safety Ground - (PE)

This is the safety ground for the drive that is required by code. One of these points must be connected to adjacent building steel (girder, joist), a floor ground rod, or bus bar. Grounding points must comply with national and local industrial safety regulations and/or electrical codes.

## Motor Ground

The motor ground must be connected to one of the ground terminals on the drive.

## Shield Termination - SHLD

Either of the safety ground terminals located on the power terminal block provides a grounding point for the motor cable shield. The **motor cable** shield connected to one of these terminals (drive end) should also be connected to the motor frame (motor end). Use a shield terminating or EMI clamp to connect the shield to the safety ground terminal. The NEMA 1/IP30 Kit may be used with a cable clamp for a grounding point for the cable shield.

When shielded cable is used for **control and signal wiring**, the shield should be grounded at the source end only, not at the drive end.

# 4.1 RFI Filter Grounding

Using single-phase drives with integral filter, or an external filter with any drive rating, may result in relatively high ground leakage currents. Therefore, the **filter must only be used in installations with grounded AC supply systems and be permanently installed and solidly grounded** (bonded) to the building power distribution ground.

Ensure that the incoming supply neutral is solidly connected (bonded) to the same building power distribution ground. Grounding must not rely on flexible cables and should not include any form of plug or socket that would permit inadvertent disconnection. Some local codes may require redundant ground connections. The integrity of all connections should be periodically checked.



## Installing Power Wiring



**ATTENTION:** The user is responsible for conforming with all applicable local and national codes. Failure to observe this precaution could result in damage to, or destruction of, the equipment.

**ATTENTION:** To avoid a possible shock hazard caused by induced voltages, unused wires in the conduit must be grounded at both ends. For the same reason, if a drive sharing a conduit is being serviced or installed, all drives using this conduit should be disabled. This will help minimize the possible shock hazard from “cross-coupled” power leads.

This chapter provides instructions on wiring output wiring to the motor and installing AC input power wiring.

### 5.1 Opening the Cover

To access the power terminal block:

Step 1. Open the cover.

- a. Press and hold in the tabs on each side of the cover.
- b. Pull the cover out and up to release (refer to figure 5.1).

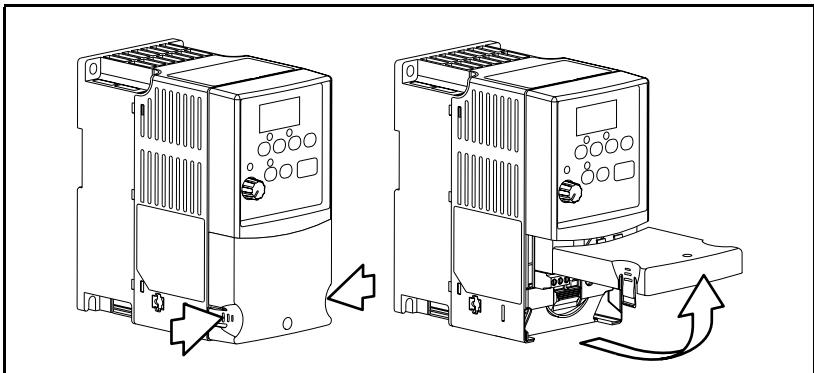

Figure 5.1 – Opening the Cover

- Step 2. Remove the finger guard (refer to figure 5.2).
- a. Press in and hold the locking tab.
  - b. Slide finger guard down and out.

Replace the finger guard and cover when wiring is complete.

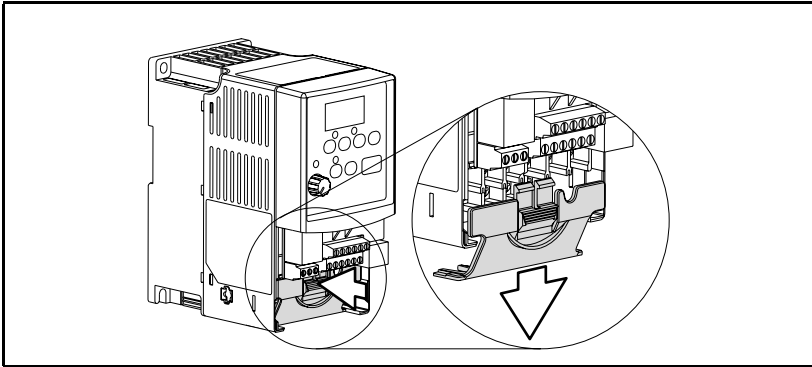

Figure 5.2 – Removing the Finger Guard

## 5.2 Verifying Drive AC Input Ratings Match Available Power

It is important to verify that plant power meets the input power requirements of the drive's circuitry. Refer to table 5.4 for input power rating specifications. Be sure input power to the drive corresponds to the drive nameplate voltage and frequency.

### 5.2.1 Ungrounded Distribution Systems



**ATTENTION:** MD65 drives contain protective MOVs that are referenced to ground. These devices should be disconnected if the drive is installed on an ungrounded distribution system.

To prevent drive damage, the MOVs connected to ground should be disconnected if the drive is installed on an ungrounded distribution system where the line-to-ground voltages on any phase could exceed 125% of the nominal line-to-line voltage.

## Disconnecting MOVs

To disconnect MOVs, you must remove the external jumper located on the lower left side of the front of the drive.

To remove the jumper, use the following procedure and refer to figures 5.3 and 5.4.

- Step 1. Open the cover.
- Step 2. Locate the screw below and to the left of the power terminal block.
- Step 3. Turn the screw counterclockwise to loosen. Do not remove screw.
- Step 4. Pull the jumper completely out of the drive chassis.
- Step 5. Tighten the screw to keep it in place.

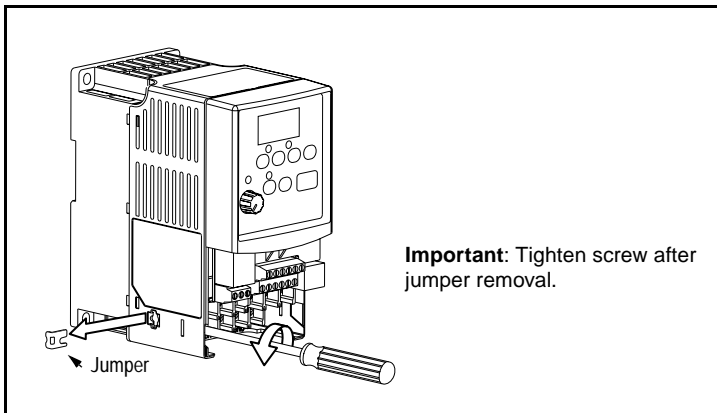

Figure 5.3 – Removing the Jumper

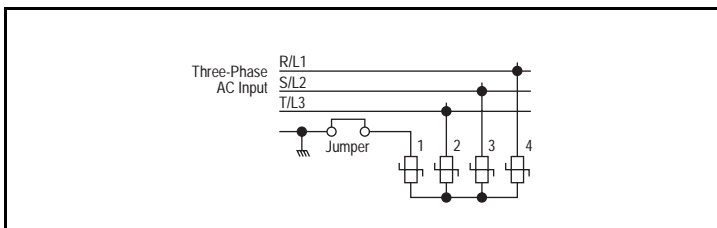

Figure 5.4 – Phase-to-Ground MOV Removal

## 5.2.2 Input Power Conditioning

The drive is suitable for direct connection to input power within the rated voltage of the drive (see table 5.4). Table 5.1 lists certain input power conditions that may cause component damage or reduction in product life. If any of the conditions exist, install one of the devices listed in the “Corrective Action” column in table 5.1 on the line side of the drive.

**Important:** Only one device per branch circuit is required. It should be mounted closest to the branch and sized to handle the total current of the branch circuit.

Table 5.1 – Corrective Actions for Input Power Conditions

Input Power Condition	Corrective Action
Low line impedance (less than 1% line reactance)	Install one of the following: <ul style="list-style-type: none"> <li>• Line reactor<sup>1</sup></li> <li>• Isolation transformer</li> </ul>
Greater than 120 kVA supply transformer	
Line has power factor correction capacitors	
Line has frequent power interruptions	
Line has intermittent noise spikes in excess of 6000V (lightning)	
Phase-to-ground voltage exceeds 125% of normal line-to-line voltage	<ul style="list-style-type: none"> <li>• Remove MOV jumper to ground and install isolation transformer with grounded secondary, if necessary.</li> </ul>
Ungrounded distribution system	

<sup>1</sup> Contact Reliance Electric for application and ordering information.

## 5.3 Power Wiring Specifications

Table 5.2 – Power Wiring Specifications

Power Wiring Rating	Recommended Copper Wire
Unshielded 600 V, 75° C (167° F) THHN/THWN	15 mils insulated, dry location
Shielded 600 V, 90°C (194°F) RHH/RHW-2	Belden 29501-29507 or equivalent
Shielded Tray rated 600 V, 90° C (194° F) RHH/RHW-2	Shawflex 2ACD/3ACD or equivalent

## 5.4 Power Terminal Block Connections

Table 5.3 – Power Terminal Block Specifications

Frame	Maximum Wire Size <sup>1</sup>	Minimum Wire Size <sup>1</sup>	Torque
B	5.3 mm <sup>2</sup> (10 AWG)	1.3 mm <sup>2</sup> (16 AWG)	1.7-2.2 Nm (16-19 in-lb)
C	8.4 mm <sup>2</sup> (8 AWG)	1.3 mm <sup>2</sup> (16 AWG)	2.9-3.7 Nm (26-33 in-lb)

<sup>1</sup> Maximum/minimum sizes that the terminal block will accept. These are not recommendations.

Terminal	Description
R/L1, S/L2	1-Phase Input
R/L1, S/L2, T/L3	3-Phase Input
U/T1	To Motor U/T1
V/T2	To Motor V/T2
W/T3	To Motor W/T3
P2, P1	DC Bus Inductor Connection (C Frame drives only) The C Frame drive is shipped with a jumper between Terminals P2 and P1. Remove this jumper only when a DC Bus Inductor will be connected. Drive will not power up without a jumper or inductor connected.
DC+, DC-	DC Bus Connection
BR+, BR-	Dynamic Brake Resistor Connection
⊕	Safety Ground - PE

Figure 5.5 – Power Terminal Block Connections

**Important:** Terminal screws may become loose during shipment. Ensure that all terminal screws are tightened to the recommended torque before applying power to the drive.

## 5.5 Fuses and Circuit Breakers

The MD65 drive does not provide branch short circuit protection. This product should be installed with either input fuses or an input circuit breaker. National and local industrial safety regulations and/or electrical codes may determine additional requirements for these installations.



**ATTENTION:** To guard against personal injury and/or equipment damage caused by improper fusing or circuit breaker selection, use only the recommended line fuses/circuit breakers specified in table 5.4.

### Fuses

The MD65 drive has been UL tested and approved for use with input fuses. The ratings in table 5.4 are the recommended values for use with each drive rating. The devices listed in this table are provided to serve as a guide. Other devices that meet the requirements of UL508C and UL489 with similar trip characteristics may be used in order to meet local or national electrical codes.

**If fuses are chosen as the desired protection method**, refer to the recommended types listed below. If available amp ratings do not match the tables provided, the **closest** fuse rating that exceeds the drive rating should be chosen.

- IEC – BS88 (British Standard) Parts 1 & 2<sup>1</sup>.
- UL – UL Class CC, T or J must be used.<sup>2</sup>

### Circuit Breakers

The circuit breaker ratings in table 5.4 are for the recommended rated devices that supply drive protection.

---

<sup>1</sup> Typical designations include, but may not be limited to the following:  
Parts 1 & 2: AC, AD, BC, BD, CD, DD, ED, EFS, EF, FF, FG, GF, GG, GH.

<sup>2</sup> Typical designations include:  
Type CC - KTK-R, FNQ-R  
Type J - JKS, LPJ  
Type T - JJS, JJN

Table 5.4 – Drive, Fuse, and Circuit Breaker Ratings

Drive Ratings								
Model Number	Output Ratings		Input Ratings			Branch Circuit Protection		Power Dissipation
	kW (HP)	Amps	Voltage Range	kVA	Amps	Fuses <sup>2</sup>	Circuit Breaker <sup>3</sup>	IP20 Open Watts
<b>100 - 120V AC 1-Phase Input, 0 - 230V 3-Phase Output</b>								
6MDVN-2P3102	0.4 (0.5)	2.3	90-132	1.15	9.0	15	15	30
6MDVN-5P0102	0.75 (1.0)	5.0	90-132	2.45	20.3	35	30	56
6MDVN-6P0102	1.1 (1.5)	6.0	90-132	3.0	24.0	40	35	70
<b>200 - 240V AC – 1-Phase<sup>1</sup> Input, 0 - 230V 3-Phase Output</b>								
6MDAN-2P3102	0.4 (0.5)	2.3	180-265	1.15	6.0	10	15	30
6MDAN-5P0102	0.75 (1.0)	5.0	180-265	2.45	12.0	20	20	55
6MDAN-8P0102	1.5 (2.0)	8.0	180-265	4.0	18.0	30	30	80
6MDAN-012102	2.2 (3.0)	12.0	180-265	5.5	25.0	40	35	110
<b>200 - 240V AC – 3-Phase Input, 0 - 230V 3-Phase Output</b>								
6MDBN-2P3102	0.4 (0.5)	2.3	180-265	1.15	2.5	6	10	30
6MDBN-5P0102	0.75 (1.0)	5.0	180-265	2.45	5.7	10	15	55
6MDBN-8P0102	1.5 (2.0)	8.0	180-265	4.0	9.5	15	15	80
6MDBN-012102	2.2 (3.0)	12.0	180-265	5.5	15.5	25	25	115
6MDBN-017102	3.7 (5.0)	17.5	180-265	8.6	21.0	35	30	165
6MDBN-024102	5.5 (7.5)	24.0	180-265	11.8	26.1	40	40	226
6MDBN-033102	7.5 (10.0)	33.0	180-265	16.3	34.6	60	60	290
<b>380 - 480V AC – 3-Phase Input, 0 - 460V 3-Phase Output</b>								
6MDDN-1P4102	0.4 (0.5)	1.4	340-528	1.4	1.8	3	10	30
6MDDN-2P3102	0.75 (1.0)	2.3	340-528	2.3	3.2	6	10	40
6MDDN-4P0102	1.5 (2.0)	4.0	340-528	4.0	5.7	10	15	60
6MDDN-6P0102	2.2 (3.0)	6.0	340-528	5.9	7.5	15	15	90
6MDDN-010102	4.0 (5.0)	10.5	340-528	10.3	13.0	20	25	150
6MDDN-012102	5.5 (7.5)	12.0	340-528	11.8	14.2	25	30	160
6MDDN-017102	7.5 (10.0)	17.0	340-528	16.8	18.4	30	30	200
6MDDN-024102	11 (15.0)	24.0	340-528	23.4	26.0	50	40	285
<b>460 - 600V AC – 3-Phase</b>								
6MDEN-1P7102	0.75 (1.0)	1.7	414-660	2.1	2.3	6	10	40
6MDEN-3P0102	1.5 (2.0)	3.0	414-660	3.65	3.8	6	10	60
6MDEN-4P2102	2.2 (3.0)	4.2	414-660	5.2	5.3	10	10	90
6MDEN-6P6102	4.0 (5.0)	6.6	414-660	8.1	8.3	15	15	150
6MDEN-9P9102	5.5 (7.5)	9.9	414-660	12.1	11.2	20	25	160
6MDEN-012102	7.5 (10.0)	12.2	414-660	14.9	13.7	25	25	200
6MDEN-019102	11 (15.0)	19.0	414-660	23.1	24.1	40	40	285

<sup>1</sup> 200-240V AC - 1-Phase drives are also available with an integral EMC filter.

- <sup>2</sup> Fuse ratings are the recommended values for use with each drive rating. Recommended fuse type: UL Class J, CC, T or Type BS88; 600 V (550 V) or equivalent.
- <sup>3</sup> Circuit breaker ratings are the recommended values for use with each drive rating.

Note: For carrier frequencies above 4 kHz, see figure 9.10.

## 5.6 Motor Cable Types Acceptable for 200-600 Volt Installations

### General

A variety of cable types are acceptable for drive installations. For many installations, unshielded cable is adequate provided it can be separated from sensitive circuits. As an approximate guide, allow a spacing of 0.3 meters (1 foot) for every 10 meters (32.8 feet) of length. In all cases, long parallel runs must be avoided. Do not use cable with an insulation thickness less than 15 mils (0.4 mm/0.015 in).

- UL installations in 50°C ambient must use 600 V, 75°C or 90°C wire.
- For UL installations in 40°C ambient, 600 V, 75°C or 90°C wire is recommended.

### Unshielded

THHN, THWN or similar wire is acceptable for drive installation in dry environments provided adequate free air space and/or conduit fill rates limits are provided. **Do not use THHN or similarly coated wire in wet areas.** Any wire chosen must have a minimum insulation thickness of 15 mil and should not have large variations in insulation concentricity.

### Shielded/Armored Cable

Shielded cable contains all of the general benefits of multi-conductor cable with the added benefit of a copper braided shield that can contain much of the noise generated by a typical AC drive. Strong consideration for shielded cable should be given in installations with sensitive equipment such as weigh scales, capacitive proximity switches, and other devices that may be affected by electrical noise in the distribution system. Applications with large numbers of drives in a similar location, imposed EMC regulations, or a high degree of communications/networking are also good candidates for shielded cable.



Shielded cable may also help reduce shaft voltage and induced bearing currents for some applications. In addition, the increased impedance of shielded cable may help extend the distance that the motor can be located from the drive without the addition of motor protective devices such as terminator networks.

Consideration should be given to all of the general specifications dictated by the environment of the installation, including temperature, flexibility, moisture characteristics and chemical resistance. In addition, a braided shield should be included and be specified by the cable manufacturer as having coverage of at least 75%. An additional foil shield can greatly improve noise containment.

A good example of recommended cable is Belden 295xx (xx determines gauge). This cable has four XLPE insulated conductors with a 100% coverage foil and an 85% coverage copper braided shield (with drain wire) surrounded by a PVC jacket.

Other types of shielded cable are available, but the selection of these types may limit the allowable cable length. Particularly, some of the newer cables twist four conductors of THHN wire and wrap them tightly with a foil shield. This construction can greatly increase the cable charging current required and reduce the overall drive performance. Unless specified in the individual distance tables as tested with the drive, these cables are not recommended and their performance against the lead length limits supplied is not known.

Refer to table 5.5 for acceptable shielded motor cable types.

Table 5.5 – Shielded Motor Cable Types Acceptable for 200-600 Volt Installations

Location	Rating/Type	Description
Standard (Option 1)	600V, 90°C (194°F) XHHW2/RHW-2 Anixter B209500- B209507 Belden 29501- 29507 or equivalent	<ul style="list-style-type: none"> <li>• Four tinned copper conductors with XLPE insulation</li> <li>• Copper braid/aluminum foil combination shield land tinned copper drain wire.</li> <li>• PVC jacket</li> </ul>
Standard (Option 2)	Tray rated 600V, 90°C (194°F) RHH/ RHW-2 Anixter OLF-7xxxxx or equivalent	<ul style="list-style-type: none"> <li>• Three tinned copper conductors with XLPE insulation</li> <li>• 5 mil single helical copper tape (25% overlap min.) with three bare copper grounds in contact with shield</li> <li>• PVC jacket</li> </ul>

Table 5.5 – Shielded Motor Cable Types Acceptable for 200-600 Volt Installations

Location	Rating/Type	Description
Class I & II; Division I & II	Tray rated 600V, 90°C (194°F) RHH/RHW-2 Anixter 7V-7xxx-3G or equivalent	<ul style="list-style-type: none"> <li>• Three bare copper conductors with XLPE insulation with impervious corrugated continuously welded aluminum armor</li> <li>• Black sunlight-resistant PVC jacket overall</li> <li>• Three copper grounds on #10 AWG and smaller</li> </ul>

## 5.7 Reflected Wave Protection

The drive should be installed as close to the motor as possible. Installations with long motor cables may require the addition of external devices, such as reactors, to limit voltage reflections at the motor (reflected wave phenomena). Contact Reliance Electric for recommendations.

The reflected wave data applies to all frequencies 2 to 16 kHz. For 240 V ratings, reflected wave effects do not need to be considered.

Table 5.6 – Maximum Cable Length Recommendation

Reflected Wave		
380-480V Ratings	Motor Insulation Rating	Motor Cable Only <sup>1</sup>
	1000 Vp-p	15 meters (49 feet)
	1200 Vp-p	40 meters (131 feet)
	1600 Vp-p	170 meters (558 feet)

<sup>1</sup> Longer cable lengths can be achieved by installing devices on the output of the drive. Consult factory for recommendations.

## 5.8 Output Disconnect

The drive is intended to be commanded by control input signals that will start and stop the motor. A device that routinely disconnects then reapplies output power to the motor for the purpose of starting and stopping the motor should not be used. If it is necessary to disconnect power to the motor with the drive outputting power, an auxiliary contact should be used to simultaneously disable drive control run commands.

## Installing Control Wiring

This chapter describes how to wire the signal and I/O terminal strip for stop, speed feedback, and remote control signals.

To access the control terminal block, remove the drive cover (refer to chapter 5).

Terminal block connections are detailed in figure 6.1.

### 6.1 Stop Circuit Requirements



**ATTENTION:** You must provide an external, hardwired emergency stop circuit outside of the drive circuitry. This circuit must disable the system in case of improper operation. Uncontrolled machine operation can result if this procedure is not followed. Failure to observe this precaution could result in bodily injury.

Depending upon the requirements of the application, the MD65 drive can be configured to provide either a coast-to-rest or a ramp-to-rest operational stop without physical separation of the power source from the motor. A coast-to-rest stop turns off the transistor power device drivers. A ramp-to-rest stop fires the transistor power device drivers until the motor comes to a stop, and then turns off the power devices.

In addition to the operational stop, you must provide a hardwired emergency stop external to the drive. The emergency stop circuit must contain only hardwired electromechanical components. Operation of the emergency stop must not depend on electronic logic (hardware or software) or on the communication of commands over an electronic network or link.

Note that the hardwired emergency stop you install can be used at any time to stop the drive.

## 6.2 Motor Start/Stop Precautions



**ATTENTION:** A contactor or other device that routinely disconnects and reapplies the AC line to the drive to start and stop the motor can cause drive hardware damage. The drive is designed to use control input signals that will start and stop the motor. If used, the input device must not exceed one operation per minute or drive damage can occur. Failure to observe this precaution can result in damage to, or destruction of, equipment.

**ATTENTION:** The drive start/stop control circuitry includes solid-state components. If hazards due to accidental contact with moving machinery or unintentional flow of liquid, gas or solids exist, an additional hardwired stop circuit may be required to remove the AC line to the drive. When the AC line is removed, there will be a loss of any inherent regenerative braking effect that might be present - the motor will coast to a stop. An auxiliary braking method may be required.

Important points to remember about I/O wiring:

- Always use copper wire.
- Wire with an insulation rating of 600V or greater is recommended.
- Control and signal wires should be separated from power wires by at least 0.3 meters (1 foot).

**Important:** I/O terminals labeled “Common” **are not** referenced to the safety ground (PE) terminal and are designed to greatly reduce common mode interference.



**ATTENTION:** Driving the 4-20 mA analog input from a voltage source could cause component damage. Verify proper configuration prior to applying input signals.

## 6.3 I/O Wiring Recommendations

Table 6.1 – Recommended Control and Signal Wire<sup>1</sup>

Wire Type(s)	Description	Minimum Insulation Rating
Belden 8760/ 9460 (or equiv.)	0.8 mm <sup>2</sup> (18AWG), twisted pair, 100% shield with drain.	300 V 75° C (167° F)
Belden 8770 (or equiv.)	0.8 mm <sup>2</sup> (18AWG), 3 conductor, shielded for remote pot only.	

<sup>1</sup> If the wires are short and contained within a cabinet that has no sensitive circuits, the use of shielded wire may not be necessary, but is always recommended.

Table 6.2 – I/O Terminal Block Specifications

Maximum Wire Size <sup>1</sup>	Minimum Wire Size <sup>1</sup>	Torque
1.3 mm <sup>2</sup> (16 AWG)	0.13 mm <sup>2</sup> (26 AWG)	0.5 to 0.8 Nm (4.4 in-lb to 7 in-lb)

<sup>1</sup> Maximum / minimum that the terminal block will accept. These are not recommendations.

### 6.3.1 Maximum Control Wire Length Recommendations

Do not exceed control wiring length of 30 meters (100 feet). Control signal cable length is highly dependent on electrical environment and installation practices. To improve noise immunity, the I/O terminal block Common must be connected to ground terminal/protective earth. If using the RS485 port, Terminal 19 should also be connected to ground terminal/protective earth.

# 6.4 Wiring the Control Terminal Block

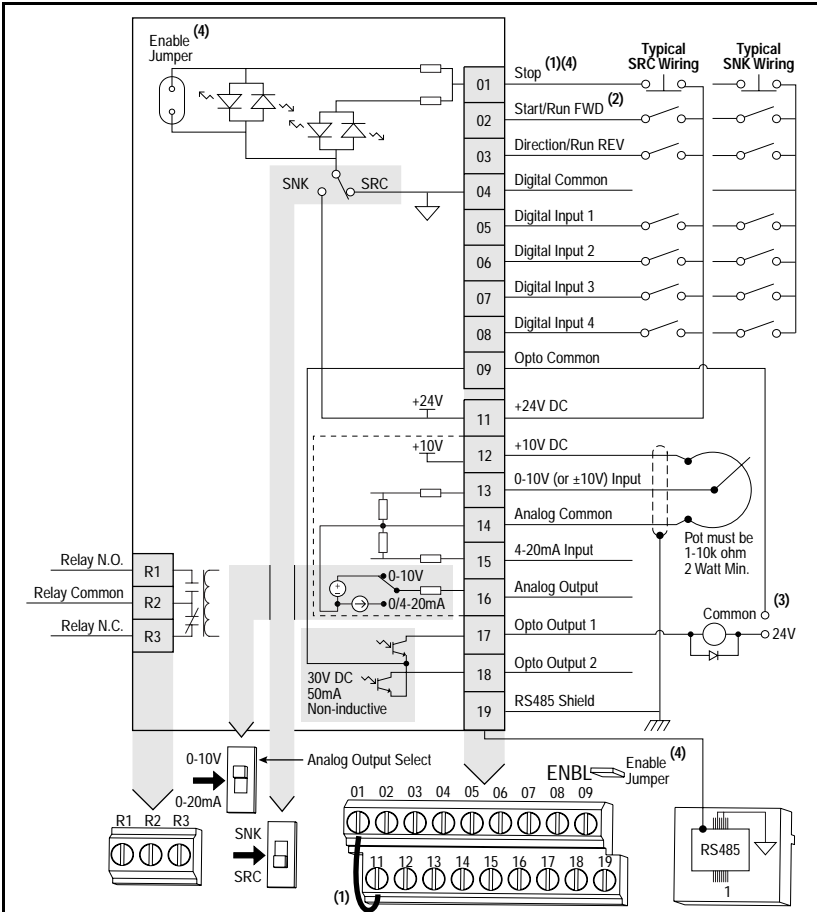

	30V DC	125V AC	240V AC
Resistive	3.0 A	3.0 A	3.0 A
Inductive	0.5 A	0.5 A	0.5 A

**Important:** I/O Terminal 01 is always a coast-to-stop input except when Start Source (P036) is set to "3-Wire Control." In three-wire control, I/O Terminal 01 is controlled by Stop Mode (P037). All other stop sources are controlled by Stop Mode (P037).

P036 (Start Source)	Stop	I/O Terminal 01 Stop
Keypad	Per P037	Coast
3-Wire	Per P037	Per P037 <sup>4</sup>
2-Wire	Per P037	Coast
RS485 Port	Per P037	Coast

- Important:** The drive is shipped with a jumper installed between I/O Terminals 01 and 11. Remove this jumper when using I/O Terminal 01 as a stop or enable input.
- <sup>2</sup>Two-wire control shown. For three-wire control, use a momentary input  $\overline{\text{O}}$  on I/O Terminal 02 to command a start. Use a maintained input  $\text{O}$  for I/O Terminal 03 to change direction.
- <sup>3</sup>When using an opto output with an inductive load such as a relay, install recovery diode parallel to the relay as shown to prevent damage to the output.
- <sup>4</sup>When the ENBL enable jumper is removed, I/O Terminal 01 will always act as a hardware enable, causing a coast to stop without software interpretation.

Figure 6.1 – Control Terminal Block



Table 6.3 – Control Terminal Definitions and Related Parameters

No.	Signal	Default	Description	Parameter
R1	Relay N.O.	Fault	Normally open contact for output relay.	A055
R2	Relay Common	-	Common for output relay.	
R3	Relay N.C.	Fault	Normally closed contact for output relay.	A055
Analog Output Select DIP Switch		0-10 V	Sets analog output to either voltage or current. Setting must match Analog Out Sel (A065).	
Sink/Source DIP Switch		Source (SRC)	Inputs can be wired as Sink (SNK) or Source (SRC) via DIP Switch setting.	
01	Stop <sup>1, 4</sup>	Coast	The factory-installed jumper or a normally closed input must be present for the drive to start.	P036 <sup>1, 4</sup>
02	Start/Run FWD	Not Active	Command comes from the integral keypad by default. To	P036, P037
03	Dir/Run REV	Not Active	disable reverse operation, see Reverse Disable (A095).	P036, P037, A095
04	Digital Common	-	For digital inputs. Electronically isolated with digital inputs from analog I/O and opto outputs.	
05	Digital Input 1	Preset Freq	Program with Digital In1 Sel (A051).	A051
06	Digital Input 2	Preset Freq	Program with Digital In2 Sel (A052).	A052
07	Digital Input 3	Local	Program with Digital In3 Sel (A053).	A053
08	Digital Input 4	Jog Forward	Program with Digital In4 Sel (A054).	A054
09	Opto Common	-	For opto-coupled outputs. Electronically isolated with opto outputs from analog I/O and digital inputs.	
11	+24V DC	-	Referenced to Digital Common. Drive supplied power for digital inputs. Maximum output current is 100 mA.	
12	+10V DC	-	Referenced to Analog Common. Drive supplied power for digital 0-10 V external potentiometer. Maximum output current is 15 mA.	P038
13	+/-10V In <sup>5</sup>	Not Active	For external 0-10 V (unipolar) or +/-10 V (bipolar) input supply (input impedance = 100 k Ohm) or potentiometer wiper.	P038, A051-A054, A123, A132
14	Analog Common	-	For 0-10 V In or 4-20 mA In. Electronically isolated with analog inputs and outputs from digital I/O and opto outputs.	
15	4-20mA In <sup>5</sup>	Not Active	For external 4-20 mA input supply (input impedance = 250 Ohm).	P038, A051-A054, A132
16	Analog Output	OutFreq 1-10	The default analog output is 0-10 V. To convert to a current value, change the Analog Output Select DIP Switch to 0-20 mA. Program with Analog Out Sel (A065). Max analog value can be scaled with Analog Out High (A066). Maximum Load: 4-20 mA = 525 ohm (10.5 V) 0-10 V = 1k ohm (10 mA)	A065, A066
17	Opto Output 1	MotorRunning	Program with A058 (Opto Out1 Sel)	A058, A059, A064
18	Opto Output 2	At Frequency	Program with A061 (Opto Out2 Sel)	A061, A062, A064
19	RS485 Shield	-	Terminal should be connected to safety ground- PE when using the RS485 communications port.	

**Important:** I/O Terminal 01 is always a coast-to-stop input except when Start Source (P036) is set to "3-Wire Control." In three-wire control, I/O Terminal 01 is controlled by Stop Mode (P037). All other stop sources are controlled by Stop Mode (P037).

**Important:** The drive is shipped with a jumper installed between I/O Terminals 01 and 11. Remove this jumper when using I/O Terminal 01 as a stop or enable input.

	P036 (Start Source)	Stop	I/O Terminal 01 Stop
	Keypad	Per P037	Coast
	3-Wire	Per P037	Per P037 <sup>4</sup>
	2-Wire	Per P037	Coast
	RS485 Port	Per P037	Coast

<sup>2</sup>Two-wire control shown. For three-wire control, use a momentary input  on I/O Terminal 02 to command a start. Use a maintained input  for I/O Terminal 03 to change direction.

<sup>3</sup>When using an opto output with an inductive load such as a relay, install recovery diode parallel to the relay as shown to prevent damage to the output.

<sup>4</sup>When the ENBL enable jumper is removed, I/O Terminal 01 will always act as a hardware enable, causing a coast to stop without software interpretation.

<sup>5</sup>0-10 V In and 4-20 mA In are distinct input channels and may be connected simultaneously. Inputs may be used independently for speed control or jointly when operating in PID mode.

## 6.4.1 I/O Wiring Examples

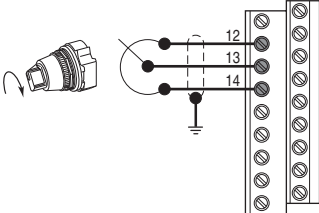
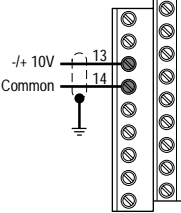
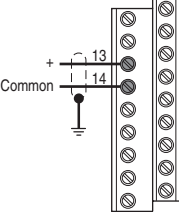
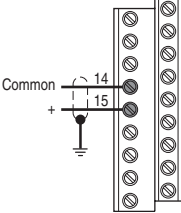
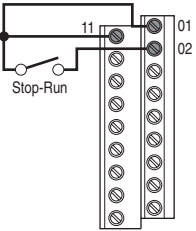
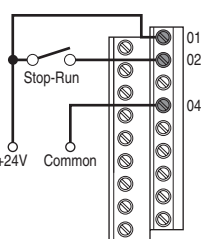
Input/Output	Connection Example		
<p><b>Potentiometer</b> 1-10k Ohm Pot. Recommended (2 Watt minimum)</p>	<p>P038 (Speed Reference) = 2 "0-10V Input"</p> 		
<p><b>Analog Input</b> 0 to +10V, 100k ohm impedance 4-20 mA, 250 ohm impedance</p>	<p><b>Bipolar</b> P038 (Speed Reference) = 2 "0-10V Input" and A123 (10V Bipolar Enbl) = 1 "Bi-Polar In"</p> 	<p><b>Unipolar (Voltage)</b> P038 (Speed Reference) = 2 "0-10V Input"</p> 	<p><b>Unipolar (Current)</b> P038 (Speed Reference) = 3 "4-20mA Input"</p> 
<p><b>2-Wire SRC Control - Non-Reversing</b> P036 (Start Source) = 2, 3 or 4 Input must be active for the drive to run. When input is opened, the drive will stop as specified by P037 (Stop Mode). If desired, a user-supplied 24 VDC power source can be used. Refer to the "External Supply (SRC)" example.</p>	<p><b>Internal Supply (SRC)</b></p> 	<p><b>External Supply (SRC)</b></p>  <p>Each digital input draws 6 mA.</p>	



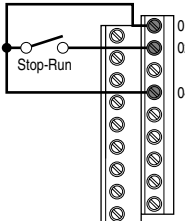
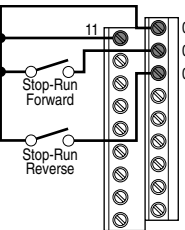
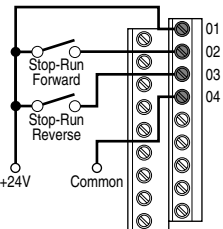
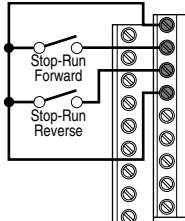
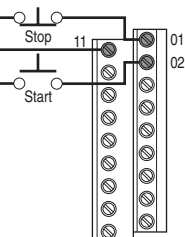
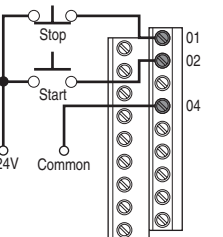

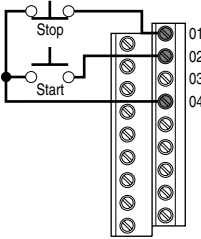
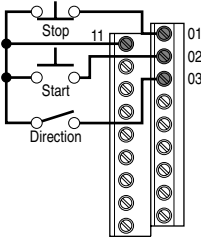
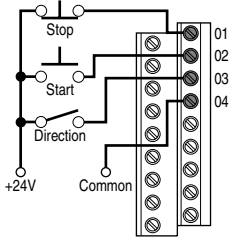
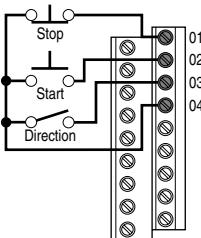
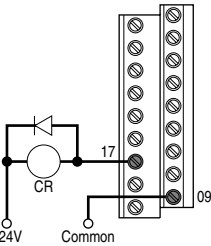
Input/Output	Connection Example	
<b>2-Wire SNK Control - Non-Reversing</b>	<b>Internal Supply (SNK)</b> 	
<b>2-Wire SRC Control - Run FWD/Run REV</b> P036 (Start Source) = 2, 3 or 4 Input must be active for the drive to run. When input is opened, the drive will stop as specified by P037 (Stop Mode). If both Run Forward and Run Reverse inputs are closed at the same time, an undetermined state could occur.	<b>Internal Supply (SRC)</b> 	<b>External Supply (SRC)</b>  <p>Each digital input draws 6 mA.</p>
<b>2-Wire SNK Control - Run FWD/Run REV</b>	<b>Internal Supply (SNK)</b> 	
<b>3-Wire SRC Control - Non-Reversing</b> P036 (Start Source) = 1 A momentary input will start the drive. A stop input to I/O Terminal 01 will stop the drive as specified by P037 (Stop Mode).	<b>Internal Supply (SRC)</b> 	<b>External Supply (SRC)</b>  <p>Each digital input draws 6 mA.</p>

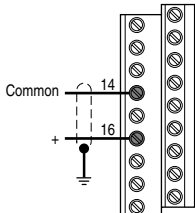
Input/Output	Connection Example	
<b>3-Wire SNK Control - Non-Reversing</b>	Internal Supply (SNK) 	
<b>3-Wire SRC Control - Reversing</b> P036 (Start Source) = 1 A momentary input will start the drive. A stop input to I/O Terminal 01 will stop the drive as specified by P037 (Stop Mode). I/O Terminal 03 determines direction.	Internal Supply (SRC) 	External Supply (SRC)  <p>Each digital input draws 6 mA.</p>
<b>3-Wire SNK Control - Reversing</b>	Internal Supply (SNK) 	
<b>Opto-Output (1 &amp; 2)</b> A058 (Opto Out1 Sel) determines Opto-Output 1 (I/O Terminal 17) operation. A061 (Opto Out2 Sel) determines Opto-Output 2 (I/O Terminal 18) operation. When using Opto-Output with an inductive load such as a relay, install a recovery diode parallel to the relay as shown, to prevent damage to the output.	Opto-Output 1  <p>Each Opto-Output is rated 30 VDC 50 mA (Non-inductive).</p>	

Input/Output	Connection Example
<b>Analog Output</b> A065 (Analog Out Sel) determines analog output type and drive conditions. 0-10V, 1k ohm minimum  0-20mA/4-20mA, 525 ohm maximum	A065 (Analog Out Sel) = 0 through 14 The Analog Output Select DIP Switch must be set to match the analog output signal mode set in A065 (Analog Out Sel).  

## 6.4.2 Typical Multiple Drive Connection Examples

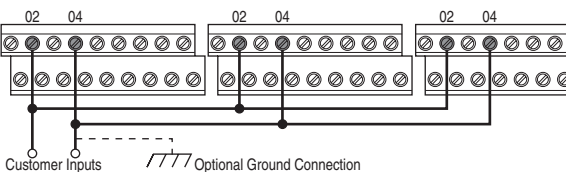
Table 6.4 – Typical Multiple Drive Connection Examples

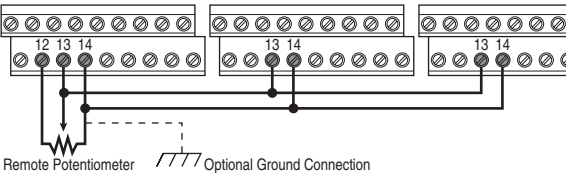
Input	Connection Example
<b>Multiple Digital Input Connections</b>	 <p>Customer Inputs      Optional Ground Connection</p> <p>When connecting a single input such as Run, Stop, Reverse or Preset Speeds to multiple drives, it is important to connect I/O Terminal 04 common together for all drives. If they are to be tied into another common (such as earth ground or separate apparatus ground) only one point of the daisy chain of I/O Terminal 04 should be connected.</p>
	<p><b>ATTENTION:</b> I/O Common terminals should <b>not</b> be tied together when using SNK (Internal Supply) mode. In SNK mode, if power is removed from one drive, inadvertent operation of other drives that share the same I/O Common connection may occur.</p>
<b>Multiple Analog Connections</b>	 <p>Remote Potentiometer      Optional Ground Connection</p> <p>When connecting a single potentiometer to multiple drives it is important to connect I/O Terminal 14 common together for all drives. I/O Terminal 14 common and I/O Terminal 13 (potentiometer wiper) should be daisy-chained to each drive. All drives must be powered up for the analog signal to be read correctly.</p>

## 6.5 Start and Speed Reference Control

The drive speed command can be obtained from a number of different sources. The source is normally determined by P038 (Speed Reference). However, when A051 or A052 (Digital Inx Select) is set to option 2, 4, 5, or 6, and the digital input is active, A051 or A052 will override the speed reference commanded by P038 (Speed Reference). See figure 6.2 for the override priority.

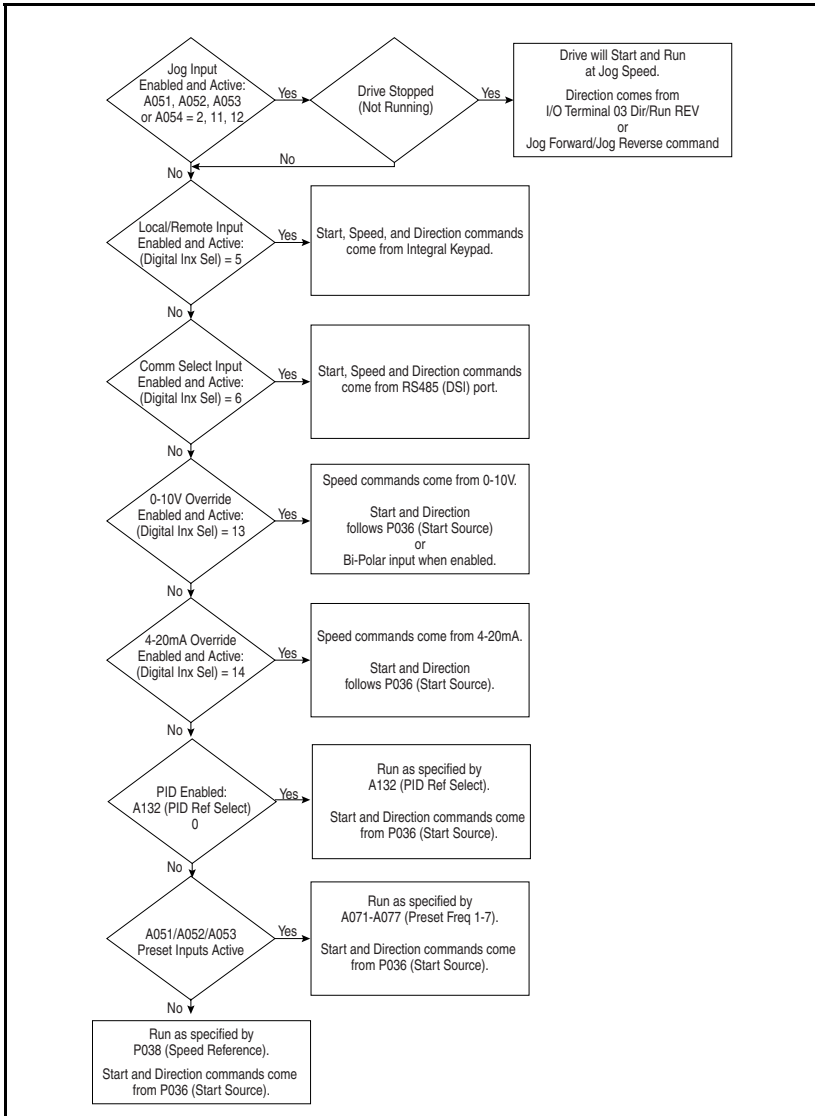

Figure 6.2 – Override Priority for the Speed Reference Command

## 6.6 Accel/Decel Selection

The selection of Accel/Decel rates can be made through digital inputs, RS485 communications and/or parameters. See figure 6.3.

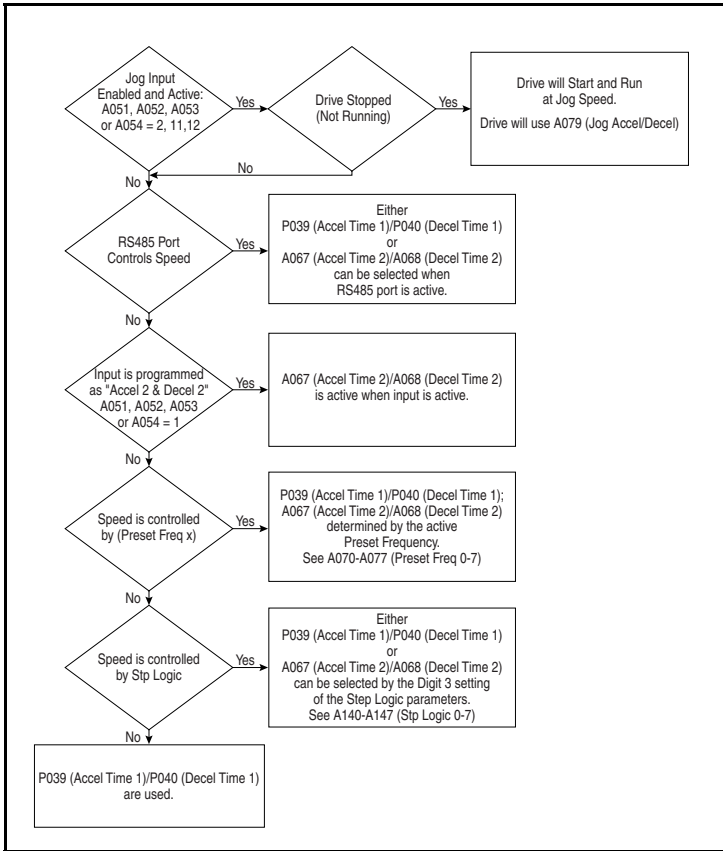

Figure 6.3 – Accel/Decel Selection



## Completing the Installation

This chapter provides instructions on how to perform a final check of the installation before and after power is applied to the drive.



**ATTENTION:** Only qualified electrical personnel familiar with the construction and operation of this equipment and the hazards involved should start and adjust it. Read and understand this manual in its entirety before proceeding. Failure to observe this precaution could result in severe bodily injury or loss of life.

### 7.1 Checking the Installation Before Applying Power to the Drive



**ATTENTION:** The drive contains high voltage capacitors that take time to discharge after removal of mains supply. Before working on the drive, ensure isolation of mains supply from line inputs [R, S, T (L1, L2, L3)]. Wait three (3) minutes for capacitors to discharge to safe voltage levels. Darkened display LEDs is not an indication that capacitors have discharged to safe voltage levels. Failure to observe this precaution could result in severe bodily injury or loss of life.

**ATTENTION:** You must provide an external, hardwired emergency stop circuit outside of the drive circuitry. This circuit must disable the system in case of improper operation. Uncontrolled machine operation can result if this procedure is not followed. Failure to observe this precaution could result in bodily injury.

To verify the condition of the installation:

- Confirm that all inputs are connected to the correct terminals and are secure.
- Verify that AC line power at the disconnect device is within the rated value of the drive.
- Verify that any external digital control power is 24 volts DC.

- Verify that the Sink (SNK)/Source (SRC) Setup DIP Switch is set to match your control wiring scheme. See figure 6.1 for the location of this switch.

**Important:** The default control scheme is Source (SRC). The Stop terminal is jumpered (I/O Terminals 01 and 11) to allow starting from the keypad. If the control scheme is changed to Sink (SNK), the jumper must be removed from I/O Terminals 01 and 11 and installed between I/O Terminals 01 and 04.

- Verify that the Stop input is present or the drive will not start.

**Important:** If I/O Terminal 01 is used as a stop input, the jumper between I/O Terminals 01 and 11 must be removed.

## 7.2 Powering Up After Installation is Complete

To verify that the drive is installed correctly and is receiving the proper line voltage, apply AC power and control voltages to the drive.

Factory default parameter values allow the drive to be controlled from the integral keypad. No programming is required to start, stop, change direction, and control speed directly from the integral keypad.

Become familiar with the integral keypad features before setting any parameters. Refer to chapter 8 for information about the integral keypad and programming the drive. To simplify drive setup, the most commonly programmed parameters are organized in the Basic parameter group.

If a fault code appears on power up, refer to chapter 10, Troubleshooting the Drive, for an explanation of the fault code.



# CHAPTER 8

## Using the Integral Keypad to Program and Control the Drive

Factory-default parameter values allow the drive to be controlled from the integral keypad. No programming is required to start, stop, change direction, or control speed directly from the integral keypad.

This chapter provides an overview of the integrated keypad and how to use it to program and control the MD65 drive.

Parameter descriptions are provided in chapter 9.

### 8.1 Keypad Components

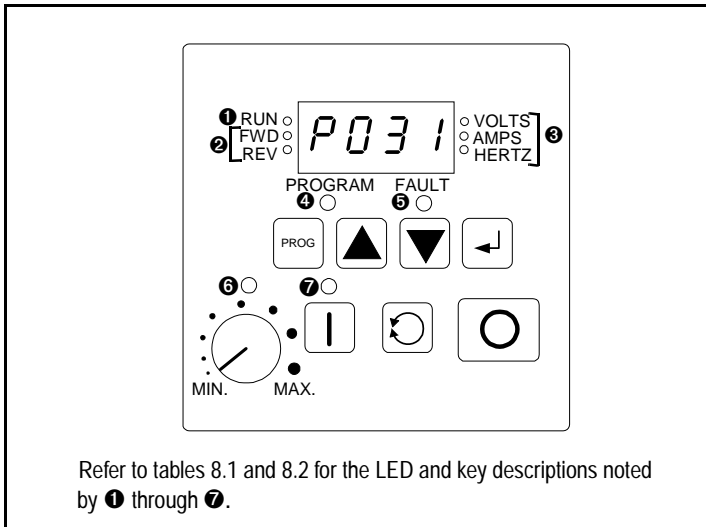

Figure 8.1 – Integral Keypad

## 8.1.1 Display Description

The alpha-numeric display indicates the following:

- Parameter number
- Parameter value
- Fault code

## 8.1.2 LED Descriptions

Refer to figure 8.1 for the location of the LEDs described in table 8.1.







Table 8.1 – LED Descriptions

No.	LED	LED State	Description
①	RUN	Steady Red	Indicates the drive is running.
②	FWD REV	Flashing Red	Drive has been commanded to change direction. Indicates actual motor direction while decelerating to zero.
		Steady Red	Indicates the commanded motor direction.
③	VOLTS AMPS HERTZ	Steady Red	Indicates the units of the parameter value being displayed.
④	PROGRAM	Steady Red	Indicates the drive is in program mode and the parameter value can be changed.
⑤	FAULT	Flashing Red	Indicates the drive is faulted.
⑥	Pot Status	Steady Green	Indicates the potentiometer on integral keypad is active.
⑦	Start Key Status	Steady Green	Indicates the Start key on integral keypad is active. The Reverse key is also active unless disabled by A095 (Reverse Disable).

## 8.1.3 Key Descriptions

Refer to figure 8.1 for the location of the keys described in table 8.2.

Table 8.2 – Key Descriptions

Key	Name	Description
	Program	<ul style="list-style-type: none"> <li>• Enter/exit program mode.</li> <li>• Scroll through parameter groups.</li> <li>• Back up one step in programming menu.</li> <li>• Cancel a change to a parameter value.</li> </ul>
	Up Arrow Down Arrow	<ul style="list-style-type: none"> <li>• Scroll through P and A parameters.</li> <li>• Increase/decrease the value of a flashing digit.</li> <li>• In Display Mode, increases/ decreases internal frequency parameter if that parameter is currently controlling the drive commanded speed.</li> </ul>
	Enter	<ul style="list-style-type: none"> <li>• Display value of P or A parameter.</li> <li>• Save a change to a parameter value.</li> <li>• Scroll through display (d) parameters.</li> </ul>
	Potentiometer	Control drive speed. Default is active. Controlled by parameter P038.
	Start	Start the drive. Default is active. Controlled by parameter P036.
	Reverse	Reverse direction of the motor. Default is active. Controlled by parameters P036 and A095.
	Stop	<ul style="list-style-type: none"> <li>• Stop the drive (if drive is running).</li> <li>• Clear fault (if drive is stopped) if Stop is set up as Stop-Clear Fault (P037 = 0, 1, 2, or 3).</li> </ul> Controlled by parameter P037.

## 8.2 About Parameters

To program the drive for a specific application, you adjust the appropriate parameters. The parameters are used to define characteristics of the drive.

There are three types of parameters:

- **Numbered List Parameters**

Numbered list parameters allow a selection from two or more options. Each item is represented by a number.

Example: Start Source (P036)

- **Bit Parameters**

Bit parameters have individual bits associated with features or conditions. If the bit is 0, the feature is off or the condition is false. If the bit is 1, the feature is on or the condition is true.

Example: Drive Status (d006)

- **Numeric Parameters**

These parameters have a single numerical value (for example, 0.1 volts).

Example: Motor NP Volts (P031)

Parameters are also either configurable or tunable, or read-only.

**Configurable parameters** can be adjusted or changed only while the drive is stopped.

**Tunable parameters** can be adjusted or changed while the drive is running or stopped.

**Read-only parameters** cannot be adjusted.

## 8.3 How Parameters are Organized

















Parameters are organized into three Parameter Groups:

- The Basic Parameter Group (Pnnn) contains the most commonly used parameters to simplify the start-up process.
- The Advanced Parameter Group (Annn) contains parameters used for more advanced applications.
- The Display Parameter Group (dnnn) contains parameters that indicate actual drive conditions.

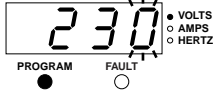

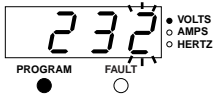
## 8.4 Viewing and Adjusting Basic (P) and Advanced (A) Parameters

Use the following procedure to view and adjust the Basic and Advanced parameters.

Table 8.3 – Viewing and Adjusting Basic (P) and Advanced (A) Parameters

Procedure	Sample Display
Step 1. Press  until the desired parameter group is displayed. The PROGRAM LED will turn on to indicate the drive is in program mode.	
Step 2. Press   to scroll through the parameters in the selected parameter group.	
Step 3. Press  to view the value of the displayed parameter.	
Step 4. Press  or   . The adjustable value will flash on the display.	
Step 5. Use   to adjust the value.	
Step 6. Press  to accept the value. The value stops flashing.	
Step 7. Press  to return to the parameter number.	







To adjust additional parameters, repeat steps 2 through 7.

To exit a parameter without saving the value, press  instead of .

## 8.5 Viewing the Display (d) Parameters

Use the procedure in table 8.4 to view Display parameters.

Table 8.4 – Viewing the Display (d) Parameters

Procedure	Sample Display
<p>Step 1. Press  to scroll through the parameter menus until the Display Group parameters are displayed. The PROGRAM LED will be off to indicate the drive is in display mode.</p>	 <p>The display shows 'd001' with 'PROGRAM' and 'FAULT' LEDs below it, both of which are off. To the right of the display are three indicators: VOLTS (off), AMPS (off), and HERTZ (off).</p>
<p>Step 2. Press  to scroll through the Display Group parameters until the desired Display parameter is displayed.</p>	 <p>The display shows 'd001' with 'PROGRAM' and 'FAULT' LEDs below it, both of which are off. To the right of the display are three indicators: VOLTS (off), AMPS (off), and HERTZ (off).</p>
<p>Step 3. The parameter value will be displayed 3 seconds after  is released.</p>	 <p>The display shows '0.0' with 'PROGRAM' and 'FAULT' LEDs below it, both of which are off. To the right of the display are three indicators: VOLTS (off), AMPS (off), and HERTZ (on).</p>

To view additional Display parameters, press  to return to the Display Group parameter list and scroll through the parameter list as described in step 2.

Note that the last user-selected Display parameter is saved when power is removed and is displayed by default when power is re-applied.



# CHAPTER 9

## Parameter Descriptions

The following information is provided for each parameter along with its description:

- Parameter Number:** Unique number assigned to each parameter.
- Parameter Name:** Unique name assigned to each parameter.
- Range:** Predefined parameter limits or selections.
- Default:** Factory default setting.
- See also:** Associated parameters that may provide additional or related information.

### What the Symbols Mean

Symbol	Meaning
	Drive must be stopped before changing parameter value.
	32-bit parameter. Parameters marked 32-bit will have two parameter numbers when using RS485 communications and programming software.

The parameters are presented in numerical order in the sections that follow. Refer to Appendix C for a list of parameters cross-referenced by parameter name.

# 9.1 Basic Program Group Parameters

The Basic Program Group contains the most commonly used parameters to simplify the start-up process.

---

## P031 Motor NP Volts



**Range:** 20 VAC to Drive Rated Volts  
**Default:** Based on Drive Rating  
**See also:** d004, A084-A087

Set to the motor nameplate rated volts.

---

## P032 Motor NP Hertz



**Range:** 15 to 400 Hz  
**Default:** 60 Hz  
**See also:** A084-A087, A090

Set to the motor nameplate rated frequency.

---

## P033 Motor OL Current

**Range:** 0.0 to (Drive Rated Amps x 2)  
**Default:** Based on Drive Rating  
**See also:** A055, A058, A061, A089, A090, A098, A114, A118

Set to the maximum allowable motor current. The drive will fault on an F7 Motor Overload if the value of this parameter is exceeded by 150% for 60 seconds or 200% for 3 sec.

---

## P034 Minimum Freq

**Range:** 0.0 to 400.0 Hz  
**Default:** 0.0 Hz  
**See also:** d001, d002, d013, P035, A085-A087, A110, A112

Sets the lowest frequency the drive will output continuously.

---

## P035 Maximum Freq



**Range:** 0 to 400 Hz  
**Default:** 60 Hz  
**See also:** d001, d002, d013, P034, A065, A078, A085-A087, A111, A113

Sets the highest frequency the drive will output.



## P036 Start Source



**Range:** 0 = Keypad  
1 = 3-Wire  
2 = 2-Wire  
3 = 2-W Lvl Sens  
4 = 2-W Hi Speed  
5 = Comm Port  
6 = Momt FWD/REV

**Default:** 0 = Keypad

**See also:** d012, P037

Sets the control scheme used to start the drive.

Refer to section 6.5, Start and Speed Reference Control, for details about how other drive settings can override the setting of this parameter.

**Important:** For all settings except option 3, the drive must receive a leading edge from the start input for the drive to start after a stop input, loss of power, or fault condition.

**0 = Keypad (Default):** Integral keypad controls drive operation. I/O Terminal 01 (Stop) on terminal block = coast to stop. When 0 is selected, the Reverse key is also active unless disabled by Reverse Disable (A095).

**1 = 3-Wire:** I/O Terminal 01 (Stop) = stop according to the value set in Stop Mode (P037). Refer to section 6.4.1 for wiring examples.

**2 = 2-Wire:** I/O Terminal 01 (Stop) = coast to stop. Refer to section 6.4.1 for wiring examples.

**3 = 2-W Lvl Sens:** Two-wire level-sensitive. Drive will restart after a Stop command when Stop is removed and Start is held active.



**ATTENTION:** When Start Source (P036) is set to 3 = 2-W Lvl Sens, and the Run input is maintained, the Run inputs do not need to be toggled after a Stop input for the drive to run again. A Stop function is provided only when the Stop input is active (open). Failure to observe this precaution could result in severe bodily injury.

**4 = 2-W Hi Speed:** Two-wire high-speed. Outputs are kept in a ready-to-run state. The drive will respond to a Start command within 10 ms. I/O Terminal 01 (Stop) = coast to stop.

**Important:** There is greater potential voltage on the power output terminals (U/T1, V/T2, W/T3) when using this option.

**5 = Comm Port:** Remote communications. I/O Terminal 01 (Stop) = coast to stop.

**6 = Momt FWD/REV:** Drive will start after a momentary input from either the Run FWD Input (I/O Terminal 02) or the Run REV Input (I/O Terminal 03). I/O Terminal 1 “Stop” = stop according to the value set in Stop Mode (P037).

## P037 Stop Mode

**Range:** 0 = Ramp, CF  
1 = Coast, CF  
2 = DC Brake, CF  
3 = DCBrkAuto, CF  
4 = Ramp  
5 = Coast  
6 = DC Brake  
7 = DC BrakeAuto  
8 = Ramp+EM B, CF  
9 = Ramp+EM Brk

**Default:** 1 = Coast, CF

**See also:** P036, A080, A081, A082, A105

Active stop mode for all stop sources [for example, keypad, run forward (I/O Terminal 02), run reverse (I/O Terminal 03), RS485 port] except as noted below.

**Important:** I/O Terminal 01 is always a coast-to-stop input except when Start Source (P036) is set for three-wire control. When three-wire control is selected, I/O Terminal 01 is controlled by Stop Mode (P037).

### Hardware Enable Circuitry

By default, I/O Terminal 01 is a coast-to-stop input. The status of the input is interpreted by drive software. If the application requires the drive to be disabled without software interpretation, a “dedicated” hardware enable configuration can be used. This is accomplished by removing the ENBL enable jumper on the control board. In this case, the drive will always coast to a stop regardless of the setting of Start Source (P036) and Stop Mode (P037).

**0 = Ramp, CF<sup>1</sup> (Default):** Ramp to stop. Stop command clears active fault.

**1 = Coast, CF<sup>1</sup>:** Coast to stop. Stop command clears active fault.

**2 = DC Brake, CF<sup>1</sup>:** DC injection braking stop. Stop command clears active fault.

**3 = DC BrkAuto, CF<sup>1</sup>:** DC injection braking stop with auto shutoff. Standard DC injection braking for the amount of time set in DC Brake Time (A080), or the drive shuts off when the drive detects that the motor is stopped. Stop command clears active fault.

---

<sup>1</sup> Stop Input also clears active fault.

**4 = Ramp:** Ramp to stop.

**5 = Coast:** Coast to stop.

**6 = DC Brake:** DC injection braking stop.

**7 = DC BrakeAuto:** DC injection braking stop with auto shutoff. Standard DC injection braking for the amount of time set in DC Brake Time (A080), or the drive shuts off if current limit is exceeded.

**8 = Ramp+EM B,CF:** Ramp to Stop with EM Brake Control. "Stop" command clears active fault.

**9 = Ramp+EM Brk:** Ramp to Stop with EM Brake Control.

---

## P038 Speed Reference

**Range:** 0 = Drive Pot  
1 = InternalFreq  
2 = 0-10V Input  
3 = 4-20mA Input  
4 = Preset Freq  
5 = Comm Port  
6 = Stp Logic  
7 = Anlg Ln Mult

**Default:** 0 = Drive Pot

**See also:** d001, d002, d012, P039, P040, A051-A054, A069, A070-A077, A110-A113, A123, A132, A140-A147, A150-A157

Sets the source of the speed reference to the drive.

The drive speed command can be obtained from a number of different sources. The source is normally determined by Speed Reference (P038). However, when Digital Inx Sel (A051-A054) is set to option 2, 4, 5, 6, 11, 12, 13, 14, or 15, and the digital input is active, or if PID Ref Sel (A132) is not set to option 0, the speed reference commanded by Speed Reference (P038) will be overridden. Refer to the flowchart in figure 6.2 for more information on speed reference control priority.

**0 = Drive Pot (Default):** Internal frequency command from the potentiometer on the integral keypad.

**1 = InternalFreq:** Internal frequency command from Internal Freq (A069).

**2 = 0-10V Input:** External frequency command from the 0 to 10 V or +/-10 V analog input or remote potentiometer.

**3 = 4-20mA Input:** External frequency command from the 4 to 20 mA analog input.

**4 = Preset Freq:** External frequency command as defined by Preset Freq x (A070-A077) when Digital Inx Sel (A051-A054) are programmed as “Preset Frequencies,” and the digital inputs are active.

**5 = Comm Port:** External frequency command from the communications port.

**6 = Stp Logic:** External frequency command as defined by Preset Freq x (A070-A077) and Stp Logic x (A140-A147).

**7 = Anlg In Mult:** External frequency command as defined by the product of the analog inputs (shown in Analog In 0-1-V (d020) and Analog In 4-20mA (d021)). [Analog In 0-10V] x [Analog In 4-20mA] = Speed Command *Example: 100% x 50% = 50%*

---

### P039 Accel Time 1

**Range:** 0.0 to 600.0 sec

**Default:** 5.0 sec

**See also:** P038, P040, A051-A054, A067, A070-A077, A140-A147

Sets the rate of acceleration for all speed increases. See figure 9.1.

Maximum Frequency / Accel Time = Accel Rate

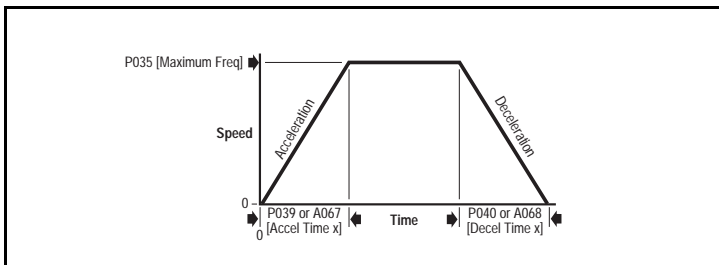

Figure 9.1 – Accel Time 1 (P039)

---

### P040 Decel Time 1

**Range:** 0.1 to 600.0 sec

**Default:** 5.0 sec

**See also:** P038, P039, A051-A054, A068, A070-A077, A140-A147

Sets the rate of deceleration for all speed decreases. See figure 9.2.

Maximum Frequency / Decel Time = Decel Rate

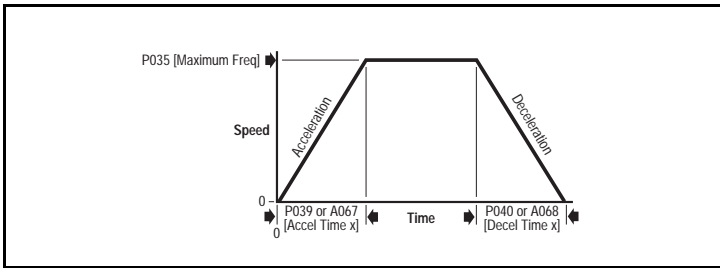

Figure 9.2 – Decel Time 1 (P040)

---

## P041 Reset To Defaults



**Range:** 0 = Ready/Idle  
1 = Factory Rset

**Default:** 0 = Ready/Idle

**See also:** N/A

Setting this parameter to 1 resets all parameter values to factory defaults. After the reset function is complete, this parameter sets itself back to 0. This selection causes an F48 Params Defaulted fault.

---

## P042 Voltage Class



**Range:** 2 = "Low Voltage" 480V  
3 = "High Voltage" 600V

**Default:** 3 = "High Voltage" 600 V

**See also:** N/A

Sets the voltage class of 600V drives.

## 9.2 Advanced Group Parameters

**A051 Digital In1 Sel (I/O Terminal 05)**  
**A052 Digital In2 Sel (I/O Terminal 06)**  
**A053 Digital In3 Sel (I/O Terminal 07)**  
**A054 Digital In4 Sel (I/O Terminal 08)**



**Range:** 0 = Not Used  
1 = Acc & Dec 2  
2 = Jog  
3 = Aux Fault  
4 = Preset Freq  
5 = Local  
6 = Comm Port  
7 = Clear Fault  
8 = RampStop,CF  
9 = CoastStop,CF  
10 = DCInjStop,CF  
11 = Jog Forward  
12 = Jog Reverse  
13 = 10V In Ctrl  
14 = 20mA In Ctrl  
15 = PID Disable  
16 = MOP Up  
17 = MOP Down  
18 = Timer Start  
19 = Counter In  
20 = Reset Timer  
21 = Reset Counter  
22 = Rset Tim&Cnt  
23 = Logic In1  
24 = Logic In2  
25 = Current Lmt2  
26 = Anlg Invert

**Default:** A051, A052, A053: 4 = Preset Freq  
A054: 5 = Local

**See also:** d012, d014, P038-P040, A067, A068, A070-A079,  
A188, A140-A147

Selects the function for the digital inputs. Refer to the flowchart in section 6.6 for more information on speed reference control priority.

**0 = Not Used:** Terminal has no function but can be read over network communications using Dig In Status (d014).

**1 = Acc & Dec 2:** When this option is selected, Accel Time 2 (A067) and Decel Time 2 (A068) are used for all ramp rates except Jog. This can only be tied to one input. Refer to the flowchart in figure 6.3 for more information about accel/decel selection.

**2 = Jog:** When the input is present, the drive accelerates according to the value set in Jog Accel/Decel (A079) and ramps to the value set in Jog Frequency (A078). When the input is removed, the drive ramps to a stop according to the value set in Jog Accel/Decel (A079). A valid Start command will override this input.

**3 = Aux Fault:** When enabled, an F2 Auxiliary Input fault will occur when the input is removed.

**4 = Preset Freq (Default for A051, A052, and A053):** Refer to Preset Freq x (A070 to A077).

**Important:** Digital inputs have priority for frequency control when programmed as Preset Speed and are active. Refer to the flowchart in figure 6.2 for more information on speed reference control priority.

**5 = Local (Default for A054):** When active, sets the integral keypad as the start source and the potentiometer on the integral keypad as the speed source.

**6 = Comm Port:** When active, sets communications device as default start/speed command source. This can only be tied to one input.

**7 = Clear Fault:** When active, clears an active fault.

**8 = RampStop,CF:** Causes drive to immediately ramp to a stop regardless of how Stop Mode (P037) is set. Stop input clears active fault.

**9 = CoastStop,CF:** Causes drive to immediately coast to a stop regardless of how Stop Mode (P037) is set. Stop input clears active fault.

**10 = DCInjStop,CF:** Causes drive to immediately begin a DC injection stop regardless of how Stop Mode (P037) is set. Stop input clears active fault.

**11 = Jog Forward :** Drive accelerates to Jog Frequency (A078) according to Jog Accel/Decel (A079) and ramps to stop when input becomes inactive. A valid start will override this command.

**12 = Jog Reverse:** Drive accelerates to Jog Frequency (A078) according to Jog Accel/Decel (A079) and ramps to stop when the input becomes inactive. A valid start will override this command.

**13 = 10V In Ctrl:** Selects 0-10 V or +/-10 V control as the frequency reference. Start source is not changed.

**14 = 20mA In Ctrl:** Selects 4-20 mA control as the frequency reference. Start source is not changed.

**15 = PID Disable:** Disables PID function. Drive uses the next valid non-PID speed reference.

**16 = MOP Up:** Increases the value of Internal Freq (A069) at a rate of 2 Hz per second. Default for A069 is 60 Hz.

**17 = MOP Down:** Decreases the value of Internal Freq (A069) at a rate of 2 Hz per second. Default for A069 is 60 Hz.

**18 = Timer Start:** Clears and starts the timer function. May be used to control the relay or opto outputs.

**19 = Counter In:** Starts the counter function. May be used to control the relay or opto outputs.

**20 = Reset Timer:** Clears the active timer.

**21 = Reset Countr:** Clears the active counter.

**22 = Rset Tm&Cnt:** Clears the active time and counter.

**23 = Logic In1:** Logic function input number 1. May be used to control the relay or opto outputs (see parameters A055, A058, A061, options 11-14). May be used with StepLogic™ parameters A140-A147.

**24 = Logic In2:** Logic function input number 2. May be used to control the relay or opto outputs (see parameters A055, A058, A061, options 11-14). May be used with StepLogic™ parameters A140-A147.

**25 = Current Lmt2:** When active, Current Limit 2 (A118) determines the drive current limit level.

**26 = Anlg Invert:** Inverts the scaling of the analog input levels set in Anlg In 0-10V Lo (A110), Anlg In 0-10V Hi (A111), Anlg In 4-20mA Lo (A112), and Anlg In 4-20mA Hi (A113).



---

## A055 Relay Out Sel

**Range:** 0 = Ready/Fault  
1 = At Frequency  
2 = MotorRunning  
3 = Reverse  
4 = Motor Overld  
5 = Ramp Reg  
6 = Above Freq  
7 = Above Cur  
8 = Above DCVolt  
9 = Retries Exst  
10 = Above Anlg V  
11 - Logic In 1  
12 = Logic In 2  
13 = Logic 1 & 2  
14 = Logic 1 or 2  
15 = StpLogic Out  
16 = Timer Out  
17 = Counter Out  
18 = Above PF Ang  
19 = Anlg In Loss  
20 = ParamControl  
21 = NonRec Fault  
22 = EM Brk Cntrl

**Default:** 0 = Ready/Fault

**See also:** P033, A056, A092, A140-A147, A150-A157

Sets the condition that changes the state of the output relay contacts.

**0 = Ready/Fault (Default):** Relay changes state when power is applied. This indicates that the drive is ready for operation. Relay returns drive to shelf state when power is removed or a fault occurs.

**1 = At Frequency:** Drive reaches commanded frequency.

**2 = MotorRunning:** Motor is receiving power from the drive.

**3 = Reverse:** Drive is commanded to run in reverse direction.

**4 = Motor Overload:** Motor overload condition exists.

**5 = Ramp Reg:** Ramp regulator is modifying the programmed accel/decel times to avoid an overcurrent or overvoltage fault.

**6 = Above Freq:** Drive exceeds the frequency (Hz) value set in Relay Output Level (A056). Use A056 to set the threshold.

**7 = Above Cur:** Drive exceeds the current (% Amps) value set in Relay Output Level (A056). Use A056 to set the threshold.

**Important:** The value for Relay Output Level must be entered in percent of drive rated output current.

**8 = Above DC Volt:** Drive exceeds the DC bus voltage value set in Relay Output Level (A056). Use A056 to set the threshold.

**9 = Retries Exst:** Number of retries set in Auto Rstrt Tries (A092) is exhausted.

**10 = Above Anlg V:** The analog input voltage (I/O Terminal 13) exceeds the value set in Relay Out Level (A056). Do not use if 10V Bipolar Enbl (A123) is set to 1 = Bi-Polar In.

**11 = Logic In 1:** An input is programmed as Logic In 1 and is active.

**12 = Logic In 2:** An input is programmed as Logic In 2 and is active.

**13 = Logic 1 & 2:** Both logic inputs are programmed and active.

**14 = Logic 1 or 2:** One or both logic inputs are programmed and one or both is active.

**15 = StpLogic Out:** Drive enters StepLogic™ step with digit 3 of the Command Word (A140-A147) set to enable the StepLogic™ output.

**16 = Timer Out:** The timer has reach the value set in Relay Out Level (A056). Use A056 to set the threshold.

**17 = Counter Out:** The counter has reached the value set in Relay Out Level (A056). Use A056 to set the threshold.

**18 = Above PF Ang:** The Power Factor angle has exceeded the value set in Relay Out Level (A056). Use A056 to set the threshold.

**19 = Anlg In Loss:** Analog input loss has occurred. Program Analog In Loss (A122) for the desired action when input loss occurs.

**20 = ParamControl:** Enables the output to be controlled over network communications by writing to Relay Out Level (A056). 0 = Off, 1 = On.

**21 = NonRec Fault:** Value set in Auto Rstrt Tries (A092) is exceeded, Auto Rstrt Tries (A092) is not enabled, or a non-resettable fault has occurred.

**22 = EM Brk Cntrl:** EM brake is energized. Program EM Brk Off Delay (A160) and EM Brk On Delay (A161) for desired action.

---

**A056 Relay Out Level****Range:** 0.0 to 9999 (see table 9.1)**Default:** 0.0**See also:** A055, A058, A061

Sets the trip point for the output relay if the value of Relay Out Sel (A055) is 6, 7, 8, 10, 16, 17, 18, or 20. See table 9.1.

Table 9.1 – Trip Points for Digital Output Relay

<b>A055 Setting</b>	<b>A056 Range</b>
6 (Above Freq)	0 to 400 Hz
7 (Above Cur)	0 to 180%
8 (Above DC Volt)	0 to 815 V
10 (Above Anlg V)	0 to 100%
16 (Timer Out)	0.1 to 9999 seconds
17 (Counter Out)	1 to 9999 counts
18 (Power Factor Angle)	1 to 180 degrees
20 (ParamControl)	0, 1

---

**A058 Opto Out1 Sel**  
**A061 Opto Out2 Sel**

**Range:**

- 0 = Ready/Fault
- 1 = At Frequency
- 2 = MotorRunning
- 3 = Reverse
- 4 = Motor Overld
- 5 = Ramp Reg
- 6 = Above Freq
- 7 = Above Cur
- 8 = Above DCVolt
- 9 = Retries Exst
- 10 = Above Anlg V
- 11 = Logic In 1
- 12 = Logic In 2
- 13 = Logic 1 & 2
- 14 = Logic 1 or 2
- 15 = StpLogic Out
- 16 = Timer Out
- 17 = Counter Out
- 18 = Above PF Ang
- 19 = Anlg In Loss
- 20 = ParamControl
- 21 = NonRec Fault
- 22 = EM Brk Cntrl

**Default:** A058: 0 = Ready/Fault  
A061: 2 = MotorRunning

**See also:** A056, A092, A140-A147, A150-A157, P033

Determines the operation of the programmable opto outputs.

**0 = Ready/Fault (A058 Default):** Opto outputs are active when power is applied. This indicates that the drive is ready for operation. Opto outputs are inactive when power is removed or a fault occurs.

**1 = At Frequency:** Drive reaches commanded frequency.

**2 = MotorRunning (A061 Default):** Motor is receiving power from the drive.

**3 = Reverse:** Drive is commanded to run in reverse direction.

**4 = Motor Overld:** Motor overload condition exists.

**5 = Ramp Reg:** Ramp regulator is modifying the programmed accel/decel times to avoid an overcurrent or overvoltage fault from occurring.

**6 = Above Freq:** Drive exceeds the frequency (Hz) value set in Opto Outx Level (A059 or A062). Use A059 or A062 to set the threshold.

**Important:** The value for A059 or A062 must be entered in percent of drive rated output current.

**7 = Above Cur:** Drive exceeds the current (% Amps) value set in Opto Outx Level (A059 or A062). Use A059 or A062 to set the threshold.

**Important:** Value for Opto Outx Level (A059 or A062) must be entered in percent of drive rated output current.

**8 = Above DCVolt:** Drive exceeds the DC bus voltage value set in Opto Outx Level (A059 or A062). Use A059 or A062 to set the threshold.

**9 = Retries Exst:** The value set in Auto Rstrt Tries (A092) is exceeded.

**10 = Above Anlg V:** The analog input voltage (I/O Terminal 13) exceeds the value set in Relay Out Level (A056). Do not use if 10 V Bipolar Enbl (A123) is set to 1 = Bi-Polar In.

**11 = Logic In 1:** An input is programmed as Logic In 1 and is active.

**12 = Logic In 2:** An input is programmed as Logic In 2 and is active.

**13 = Logic 1 & 2:** Both logic inputs are programmed and active.

**14 = Logic 1 or 2:** One or both logic inputs are programmed and one or both is active.

**15 = StpLogic Out:** Drive enters StepLogic™ step with digit 3 of the Command Word (A140-A147) set to enable the StepLogic™ output.

**16 = Timer Out:** The timer has reached the value set in Opto Outx Level (A059 or A062). Use A059 or A062 to set the threshold.

**17 = Counter Out:** The counter has the reached the value set in Opto Outx Level (A059 or A062). Use A059 or A062 to set the threshold.

**18 = Above PF Ang:** The Power Factor angle has exceeded the value set in Opto Outx Level (A059 or A062). Use A059 or A062 to set the threshold.

**19 = Anlg In Loss:** An analog input loss has occurred. Program Analog In Loss (A122) for action desired when input loss occurs.

**20 = ParamControl:** Enables the output to be controlled over network communications by writing to Opto Outx Level (A059 or A062). (0=Off, 1=On)

**21 = NonRec Fault:** Value set in Auto Rstrt Tries (A092) is exceeded, Auto Rstrt Tries (A092) is not enabled, or a non-resettable fault has occurred.

**22 = EM Brk Cntrl:** EM brake is energized. Program EM Brk Off Delay (A160) and EM Brk On Delay (A161) for desired action.

**A059 Opto Out1 Level**  
**A062 Opto Out2 Level**



**Range:** 0.0 to 9999  
**Default:** 0.0  
**See also:** A058, A061

Determines the on/off point for the opto outputs when Opto Outx Sel (A058 or A061) is set to option 6, 7, 8, 10, 16, 17, 18, or 20. Refer to table 9.2.

Table 9.2 – On/Off Points for the Opto Outputs

A058 & A061 Setting	A059 & A062 Range
6 (Above Freq)	0 to 400 Hz
7 (Above Cur)	0 to 180%
8 (Above DCVolt)	0 to 815 V
10 (Above Anlg V)	0 to 100%
16 (Timer Out)	0.1 to 9999 seconds
17 (Counter Out)	1 to 9999 counts
18 (Above PF Ang)	1 to 180 degrees
20 (ParamControl)	0, 1

**A064 Opto Out Logic**

**Range:** 0 to 3 (see table 9.3)  
**Default:** 0  
**See also:** N/A

Determines the logic (Normally Open/NO or Normally Closed/NC) of the opto outputs. Refer to table 9.3.

Table 9.3 – A064 Options

A064 Option	Opto Out1 Logic	Opto Out2 Logic
0	NO (Normally Open)	NO (Normally Open)
1	NC (Normally Closed)	NO (Normally Open)
2	NO (Normally Open)	NC (Normally Closed)
3	NC (Normally Closed)	NC (Normally Closed)

## A065 Analog Out Sel

**Range:** 0 to 20

**Default:** 0

**See also:** A066, P035

Sets the analog output signal mode (0-10 V, 0-20 mA, or 4-20 mA). The output is used to provide a signal that is proportional to several drive conditions.

Table 9.4 – Analog Output Signal Mode Selections

Option	Output Range	Minimum Output Value	Maximum Output Value A066 (Analog Out High)	DIP Switch Position
0 = OutFreq 0-10	0-10 V	0 V = 0 Hz	P035 (Maximum Freq)	0-10 V
1 = OutCurr 0-10	0-10 V	0 V = 0 Amps	200% Drive Rated Output Current	0-10 V
2 = OutVolt 0-10	0-10 V	0 V = 0 Volts	120% Drive Rated Output Volts	0-10 V
3 = OutPowr 0-10	0-10 V	0 V = 0 kW	200% Drive Rated Power	0-10 V
4 = TstData 0-10	0-10 V	0 V = 0000	65535 (Hex FFFF)	0-10 V
5 = OutFreq 0-20	0-20 mA	0 mA = 0 Hz	P035 (Maximum Freq)	0-20 mA
6 = OutCurr 0-20	0-20 mA	0 mA = 0 Amps	200% Drive Rated Output Current	0-20 mA
7 = OutVolt 0-20	0-20 mA	0 mA = 0 Volts	120% Drive Rated Output Volts	0-20 mA
8 = OutPowr 0-20	0-20 mA	0 mA = 0 kW	200% Drive Rated Power	0-20 mA
9 = TstData 0-20	0-20 mA	0 mA = 0000	65535 (Hex FFFF)	0-20 mA
10 = OutFreq 4-20	4-20 mA	4 mA = 0 Hz	P035 (Maximum Freq)	0-20 mA
11 = OutCurr 4-20	4-20 mA	4 mA = 0 Amps	200% Drive Rated Output Current	0-20 mA
12 = OutVolt 4-20	4-20 mA	4 mA = 0 Volts	120% Drive Rated Output Volts	0-20 mA
13 = OutPowr 4-20	4-20 mA	4 mA = 0 kW	200% Drive Rated Power	0-20 mA
14 = TstData 4-20	4-20 mA	4 mA = 0000	65535 (Hex FFFF)	0-20 mA
15 = OutTorq 0-10	0-10 V	0V = 0 Amps	200% Drive Related FLA	0-10 V
16 = OutTorq 0-20	0-20 mA	0 mA = 0 Amps	200% Drive Related FLA	0-20 mA
17 = OutTorq 4-20	4-20 mA	4 mA = 0 Amp	200% Drive Related FLA	0-20 mA
18 = Setpnt 0-10	0-10 V	0V = 0%	100.0% Setpoint Setting	0-10 V
19 = Setpnt 0-20	0-20 mA	0 mA = 0%	100.0% Setpoint Setting	0-20 mA
20 = Setpnt 4-20	4-20 mA	4 mA = 0%	100.0% Setpoint Setting	0-20 mA

## A066 Analog Out High

**Range:** 0 to 800%

**Default:** 100%

**See also:** A065

Scales the Maximum Output Value for the Analog Out Sel (A065) source setting.

For example:

A066 Setting	A065 Setting	A065 Max. Output Value
50%	1 = OutCurr 0-10	5 V for 200% Drive Rated Output Current
90%	8 = OutPowr 0-20	18 mA for 200% Drive Rated Power

## A067 Accel Time 2

**Range:** 0.0 to 600.0 sec

**Default:** 10.0 sec

**See also:** P039, A051-A054, A070-A077, A140-A147

Sets the rate of acceleration for speed increases except jog. Refer to the flowchart in figure 6.3 for details. Refer to figure 9.3.

Maximum Frequency / Accel Time = Accel Rate

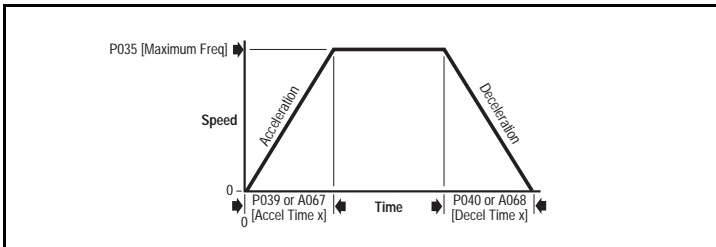

Figure 9.3 – Accel Time 2 (A067)

## A068 Decel Time 2

**Range:** 0.1 to 600.0 sec

**Default:** 10.0 sec

**See also:** P040, A051-A054, A070-A077, A140-A147

Sets the rate of deceleration for speed decreases except jog. Refer to the flowchart in figure 6.3 for details. See figure 9.4.



Maximum Frequency / Decel Time = Decel Rate

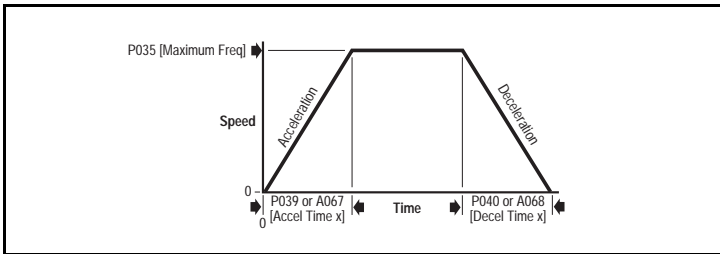

Figure 9.4 – Decel Time 2 (A068)

## A069 Internal Freq

**Range:** 0.0 to 400.0 Hz

**Default:** 0.0 Hz

**See also:** P038

Provides the frequency command to the drive when Speed Reference (P038) is set to 1=Internal Frequency. When enabled, this parameter will change the frequency command in “real time”

using the integral keypad   keys when in program mode.

**Important:** Once the desired command frequency is reached, the

 key must be pressed to store this value to

EEPROM memory. If the  key is used before the

 key, the frequency will return to the original value following the normal accel/decel curve.

If Digital Inx Sel (A-051-A054) is set to 16 = MOP Up or 17 = MOP Down, this parameter acts as the MOP frequency reference.

**A070 Preset Freq 0<sup>1</sup>**  
**A071 Preset Freq 1**  
**A072 Preset Freq 2**  
**A073 Preset Freq 3**  
**A074 Preset Freq 4**  
**A075 Preset Freq 5**  
**A076 Preset Freq 6**  
**A077 Preset Freq 7**

**Range:** 0.0 to 400.0 Hz

**Default:** 0.0 Hz

**See also:** P038, P039, P040, A051-A053, A067, A068, A140-A147, A150-A157

<sup>1</sup> To activate Preset Freq 0, set P038 (Speed Reference) to 4 = Preset Freq

Provides a fixed frequency command value when Digital Inx Sel (A051-A053) is set to 4 = Preset Frequencies. An active preset input will override the speed command as shown in the flowchart in figure 6.2. See table 9.5.

Table 9.5 – Selecting the Reference Source Using Presets

Input State of Digital In 1 (I/O Terminal 05 when A051 = 4)	Input State of Digital In 2 (I/O Terminal 06 when A052 = 4)	Input State of Digital In 3 (I/O Terminal 07 when A053 = 4)	Frequency Source	Accel / Decel Parameter Used <sup>1</sup>
0	0	0	A070 (Preset Freq 0)	Accel Time 1 / Decel Time 1
1	0	0	A071 (Preset Freq 1)	Accel Time 1 / Decel Time 1
0	1	0	A072 (Preset Freq 2)	Accel Time 2 / Decel Time 2
1	1	0	A073 (Preset Freq 3)	Accel Time 2 / Decel Time 2
0	0	1	A074 (Preset Freq 4)	Accel Time 1 / Decel Time 1
1	0	1	A075 (Preset Freq 5)	Accel Time 1 / Decel Time 1
0	1	1	A076 (Preset Freq 6)	Accel Time 2 / Decel Time 2
1	1	1	A077 (Preset Freq 7)	Accel Time 2 / Decel Time 2

<sup>1</sup> When a digital input is set to "Accel 2 & Decel 2," and the input is active, that input overrides the settings in this table.

## A078 Jog Frequency

**Range:** 0.0 to Maximum Frequency (P035)

**Default:** 10.0 Hz

**See also:** P035, A051-A054, A079

Sets the output frequency when a jog command is issued. See parameters A051-A054 for information on how to jog the drive.

## A079 Jog Accel/Decel

**Range:** 0.1 to 600.0 sec

**Default:** 10.0 sec

**See also:** A051-A054, A078

Sets the acceleration and deceleration time when a jog command is issued. Refer to parameters A051-A054 for information on how to jog the drive.

## A080 DC Brake Time

**Range:** 0.0 to 99.9 sec (A setting of 99.9 = Continuous)

**Default:** 0.0 sec

**See also:** P037, A081

Sets the length of time that DC brake current is “injected” into the motor. Refer to DC Brake Level (A081).

## A081 DC Brake Level

**Range:** 0.0 to (Drive Rated Amps x 1.8)

**Default:** Drive Rated Amps x 0.05

**See also:** P037, A080

Defines the maximum DC brake current, in amps, applied to the motor when Stop Mode (P037) is set to either DC Brake or Ramp. See figure 9.5.



**ATTENTION:** If a hazard of injury due to movement of equipment or material exists, an auxiliary mechanical braking device must be used.

**ATTENTION:** This feature should not be used with synchronous or permanent magnet motors. Motors may be demagnetized during braking.

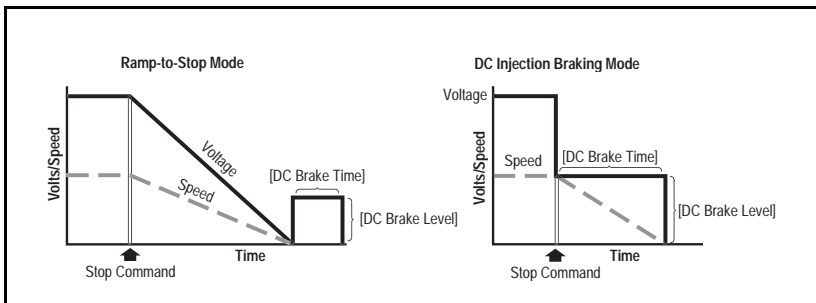

Figure 9.5 – DC Brake Level (A081)

## A082 DB Resistor Sel



**Range:** 0 = Disabled  
1 = Normal RA Resistor (5% Duty Cycle)  
2 = No Protection (100% Duty Cycle)  
3 to 99 = Duty Cycle Limited (3% to 99% Duty Cycle)

**Default:** 0 = Disabled

**See also:** P037

Enables/disables external dynamic braking.

## A083 S Curve %

**Range:** 0 to 100%

**Default:** 0% (Disabled)

**See also:** N/A

Sets the percentage of acceleration or deceleration time that is applied to the ramp as an S Curve. Time is added, 1/2 at the beginning and 1/2 at the end of the ramp.

For example: If Accel Time = 10 seconds, and the S Curve % setting is 50%, the S Curve time will be  $10 \times 0.5 = 5$  seconds. The total time will be  $10 + 5 = 15$  seconds.

See figure 9.6 for an example.

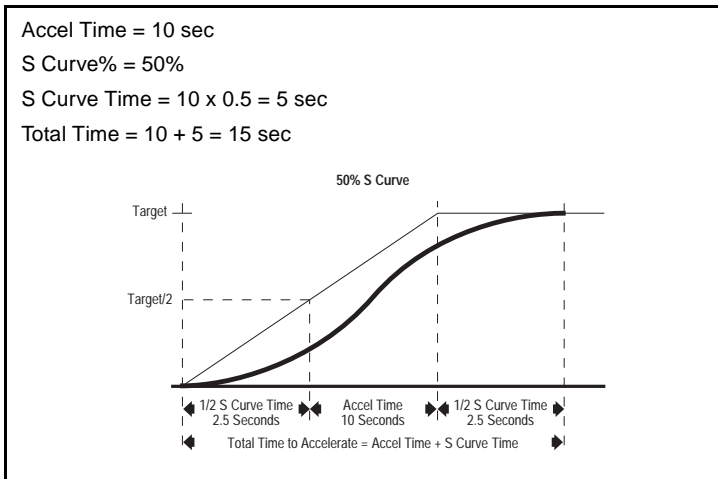

Figure 9.6 – S Curve % (A083) Example

## A084 Boost Select

**Range:** 0 = Custom V/Hz

**Variable Torque** (typical fan/pump curves):

1 = 30.0, VT

2 = 35.0, VT

3 = 40.0, VT

4 = 45.0, VT

**Constant Torque:**

5 = 0.0 no IR Compensation

6 = 0.0

7 = 2.5, CT

8 = 5.0, CT

9 = 7.5, CT

10 = 10.0, CT

11 = 12.5, CT

12 = 15.0, CT

13 = 17.5, CT

14 = 20.0, CT

**Default:** 8 = 5.0, CT

7 = 2.5, CT (for 4.0, 5.5, 7.5 kW (5.0, 7.5, and 10.0 HP) drives only)

**See also:** d004, P031, P032, A085-A087, A125

Sets the boost voltage (% of Motor NP Volts (P031)) and redefines the Volts per Hz curve. Active when Torque Perf Mode (A125) is set to 0 = V/Hz. Note that the drive may add additional voltage unless option 5 is selected. See figure 9.7.

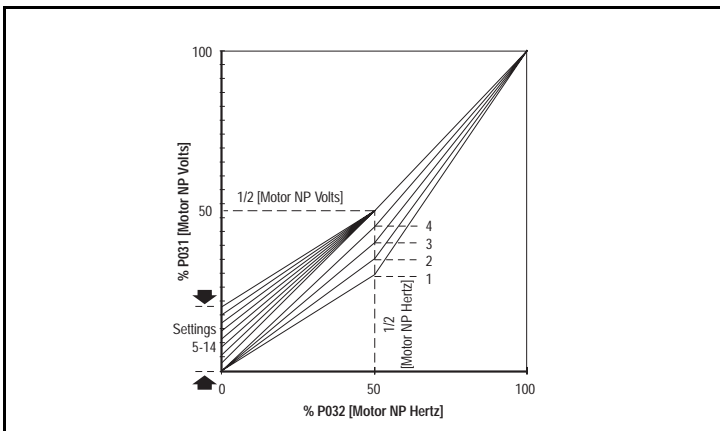

Figure 9.7 – Boost Select (A084)

## A085 Start Boost

**Range:** 0.0 to 25.0%  
**Default:** 5.0%  
**See also:** P031, P032, P034, P035, A084, A086, A087, A088, A125

Sets the boost voltage (% of Motor NP Volts (P031)) and redefines the Volts per Hz curve when Boost Select (A084) is set to 0 = Cust V/Hz, and Torque Perf Mode (A125) is set to 0 = V/Hz.

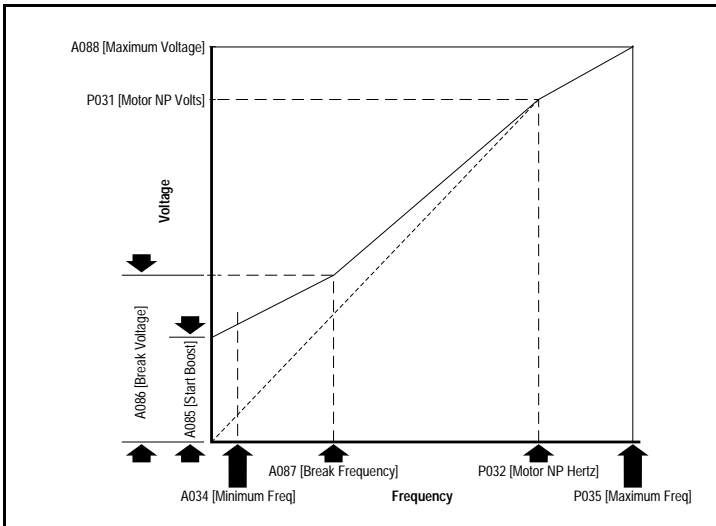

Figure 9.8 – Start Boost (A085)

## A086 Break Voltage

**Range:** 0.0 to 100.0%  
**Default:** 25.0%  
**See also:** P031, P032, P034, P035, A084, A085, A087, A088, A125

Sets the frequency where break voltage is applied when Boost Select (A084) is set to 0 = Custom V/Hz, and Torque Perf Mode (A125) is set to 0 = V/Hz.

## A087 Break Frequency

**Range:** 0.0 to 400.0 Hz

**Default:** 15.0 Hz

**See also:** P031, P032, P034, P035, A084, A085, A086, A088, A125

Sets the frequency where the break frequency is applied when Boost Select (A084) is set to 0 = Custom V/Hz, and Torque Perf Mode (A125) is set to 0 = V/Hz.

## A088 Maximum Voltage

**Range:** 20 to Drive Rated Volts

**Default:** Drive Rated Volts

**See also:** d004, A085, A086, A087

Sets the highest voltage the drive will output.

## A089 Current Limit 1

**Range:** 0.1 to (Drive Rated Amps x 1.8)

**Default:** Drive Rated Amps x 1.8

**See also:** P033, A118

Maximum output current allowed before current limiting occurs.

## A090 Motor OL Select

**Range:** 0 = No Derate  
1 = Min Derate  
2 = Max Derate

**Default:** 0 = No Derate

**See also:** P032

The drive provides Class 10 motor overload protection. Settings 0-2 select the derating factor for the  $I^2t$  overload function. See figure 9.9.

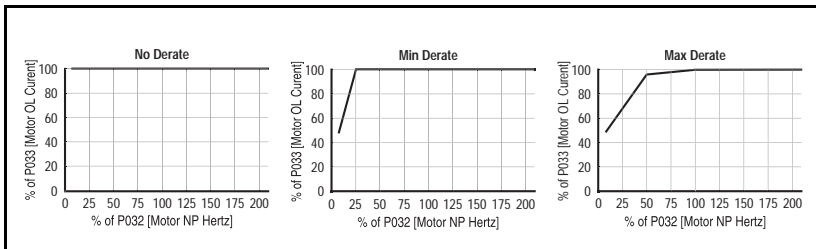

Figure 9.9 – Motor OL Select (A090)

## A091 PWM Frequency

**Range:** 2.0 to 16.0 kHz

**Default:** 4.0 kHz

**See also:** A124

Sets the carrier frequency for the PWM output waveform. Figure 9.10 provides derating guidelines based on the PWM frequency setting.

**Important:** Ignoring derating guidelines can cause reduced drive performance.

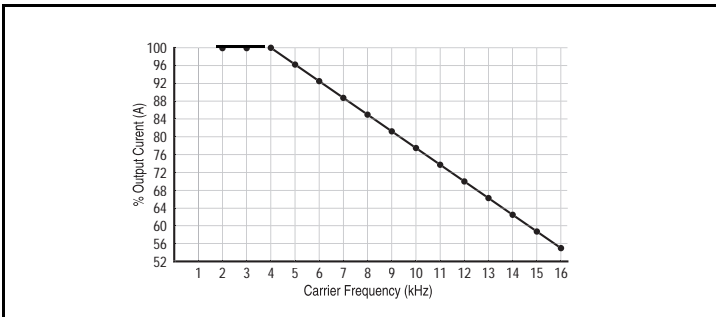

Figure 9.10 – Derating Guidelines Based on PWM Frequency (A091) Selection

## A092 Auto Rstrt Tries

**Range:** 0 to 9

**Default:** 0

**See also:** A055, A058, A061, A093

Sets the maximum number of times the drive attempts to reset a fault and restart. Refer to section 10.1.2 for more information on the Auto Restart/Run feature.



**ATTENTION:** Equipment damage and/or personal injury may result if this parameter is used in an inappropriate application. Do not use this function without considering applicable local, national, and international codes, standards, regulations, or industry guidelines.



---

### A093 Auto Rstrt Delay

**Range:** 0.0 to 300.0 sec  
**Default:** 1.0 sec  
**See also:** A092

Sets the time between restart attempts when Auto Rstrt Tries (A092) is set to a value other than zero. Refer to section 10.1.2 for more information on the Auto Restart/Run feature.

---

### A094 Start At PowerUp



**Range:** 0 = Disabled  
1 = Enabled  
**Default:** 0 = Disabled  
**See also:** N/A

Enables/disables a feature that allows a Start or Run command to automatically cause the drive to resume running at commanded speed after drive input power is restored. Requires a digital input configured for Run or Start and a valid start contact.

This parameter will not function if Start Source (P036) is set to 4 = 2-W High Speed.



**ATTENTION:** Equipment damage and/or personal injury may result if this parameter is used in an inappropriate application. Do not use this function without considering applicable local, national, and international codes, standards, regulations, or industry guidelines.

---

### A095 Reverse Disable



**Range:** 0 = Rev Enabled  
1 = Rev Disabled  
**Default:** 0 = Rev Enabled  
**See also:** d006

Enables/disables the function that allows the direction of motor rotation to be changed. The reverse command may come from a digital command, the keypad, or a serial command. All reverse inputs including two-wire Run Reverse will be ignored with reverse disabled.

---

## A096 Flying Start En

**Range:** 0 = Disabled  
1 = Enabled

**Default:** 0 = Disabled

**See also:** N/A

Enables/disables feature that allows the drive to reconnect to a spinning motor at actual RPM.



**ATTENTION:** When starting with this feature enabled, the motor may temporarily run up to the maximum speed setting before settling at the speed setpoint. Stay clear of rotating machinery. Failure to observe this precaution could result in bodily injury.

---

## A097 Compensation

**Range:** 0 = Disabled  
1 = Electrical  
2 = Mechanical  
3 = Both

**Default:** 1 = Electrical

**See also:** N/A

Enables/disables correction options that may improve problems with motor instability.

**1 = Electrical:** Some drive/motor combinations have inherent instabilities that are exhibited as non-sinusoidal motor currents. This setting attempts to correct this condition.

**2 = Mechanical:** Some motor/load combinations have mechanical resonances that can be excited by the drive current regulator. This setting slows down the current regulator response and attempts to correct this condition.

---

## A098 SW Current Trip

**Range:** 0.0 to (Drive Rated Amps x 2)

**Default:** 0.0 (Disabled)

**See also:** P033

Enables/disables a software instantaneous (within 100 ms) current trip.

---

## A099 Process Factor (Display Scaling)

**Range:** 0.1 to 999.9  
**Default:** 30.0  
**See also:** d010

Scales the value displayed by Process Display (d010).

Output Frequency x Process Factor = Process Display

---

## A100 Fault Clear



**Range:** 0 = Ready/Idle  
1 = Reset Fault  
2 = Clear Buffer (d007 - d009)  
**Default:** 0 = Ready/Idle  
**See also:** d007 - d009

Resets a fault and clears the fault buffer (parameters d007 through d009). Used primarily to clear a fault over network communications.

1 = Reset Fault: Clears the active fault and resets the drive.

2 = Clear Buffer: Clears fault codes from parameters d007 through d009.

---

## A101 Program Lock

**Range:** 0 = Unlocked  
1 = Locked  
**Default:** 0 = Unlocked  
**See also:** N/A

When set to 1 = Locked, protects parameters against change by unauthorized personnel.

---

## A102 Testpoint Sel

**Range:** 0 to FFFF  
**Default:** 400  
**See also:** d019

Used by Rockwell Automation field service personnel.

---

### A103 Comm Data Rate

**Range:** 0 = 1200  
1 = 2400  
2 = 4800  
3 = 9600  
4 = 19.2 K  
5 = 38.4 K

**Default:** 4 = 19.2 K

**See also:** d015

Sets the serial port rate for the RS485 port.

**Important:** Power to the drive must be cycled before any changes will affect drive operation.

---

### A104 Comm Node Addr

**Range:** 1 to 247

**Default:** 1

**See also:** d015

Sets the drive node address for the RS485 port if using a network connection.

**Important:** Power to the drive must be cycled before any changes will affect drive operation.

---

### A105 Comm Loss Action

**Range:** 0 = Fault  
1 = Coast Stop  
2 = Stop  
3 = Continu Last

**Default:** 0 = Fault

**See also:** d015, P037, A106

Selects the drive's response to a loss of the communication connection or excessive communication errors.

**0 = Fault (Default):** Drive will fault on an F81 Comm Loss and coast to stop.

**1 = Coast Stop:** Stops the drive via coast to stop.

**2 = Stop:** Stops the drive via the setting in Stop Mode (P037).

**3 = Continu Last:** Drive continues operating at communication commanded speed saved in RAM.

---

## A106 Comm Loss Time

**Range:** 0.1 to 60.0 sec  
**Default:** 5.0 sec  
**See also:** d015, A105

Sets the time that the drive will remain in communication loss before implementing the option selected in Comm Loss Action (A105).

---

## A107 Comm Format

**Range:** 0 = RTU 8-N-1      3 = RTU 8-N-2  
1 = RTU 8-E-1      4 = RTU 8-E-2  
2 = RTU 8-O-1      5 = RTU 8-O-2  
**Default:** 0 = RTU 8-N-1  
**See also:** N/A

Selects the protocol (RTU only), data bits (8 data bits only), parity (None, Even, Odd), and stop bits (1 stop bit only) used by the drive's RS485 port.

**Important:** Power to the drive must be cycled before any changes will affect drive operation.

---

## A108 Language



**Range:** 1 = English  
2 = Francais  
3 = Espanol  
4 = Italiano  
5 = Deutsch  
6 = Reserved  
7 = Portugues  
8 = Reserved  
9 = Reserved  
10 = Nederlands  
**Default:** 1 = English  
**See also:** N/A

Selects the language displayed by the remote communications option.

## A109 Anlg Out Setpoint

**Range:** 0.0 to 100%  
**Default:** 0.0%  
**See also:** A065

Sets the percentage of output desired by the user. If this is enabled via Analog Out Sel (A065), this determines the analog value that is output from the analog output (V or mA).

## A110 Anlg In 0-10V Lo



**Range:** 0.0 to 100.0%  
**Default:** 0.0%  
**See also:** d020, P034, P038, A122

Sets the analog input level that corresponds to Minimum Freq (P034) if a 0-10V input is used by Speed Reference (P038).

Setting this value larger than Anlg In 0-10V Hi (A111) inverts the analog signal.

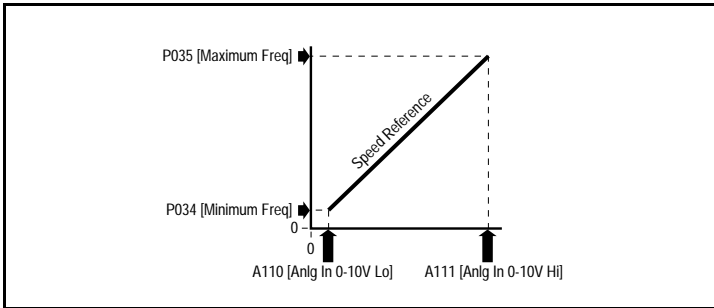

Figure 9.11 – Anlg In 0-10V Lo (A110)

## A111 Anlg In 0-10V Hi



**Range:** 0.0 to 100.0%  
**Default:** 100.0%  
**See also:** d020, P035, P038, A122, A123

Sets the analog input level that corresponds to Maximum Freq (P035) if a 0-10 V input is used by Speed Reference (P038).

Setting this value smaller than Anlg In 0-10V Lo (A110) inverts the analog signal.

---

**A112 Anlg In4-20mA Lo**

**Range:** 0.0 to 100.0%  
**Default:** 0.0%  
**See also:** d021, P034, P038

Sets the analog input level that corresponds to Minimum Freq (P034) if a 40-20 mA input is used by Speed Reference (P038).

Setting this value larger than Anlg In4-20mA Hi (A113) inverts the analog signal.

---

**A113 Anlg In4-20mA Hi**

**Range:** 0.0 to 100.0%  
**Default:** 100.0%  
**See also:** d021, P035, P038

Sets the analog input level that corresponds to Maximum Freq (P035) if a 4-20 mA input is used by Speed Reference (P038).

Setting this parameter to a value less than Anlg In4-20mA Lo (A112) inverts the analog signal.

---

**A114 Slip Hertz @ FLA**

**Range:** 0.0 to 10.0 Hz  
**Default:** 2.0 Hz  
**See also:** P033

Enables compensation for the inherent slip in an induction motor. This frequency is added to the commanded output frequency based on motor current. If motor shaft speed decreases significantly under heavy loads, then increase the value of this parameter. Setting this parameter to 0.0 disables this function.

---

**A115 Process Time Lo**

**Range:** 0.00 to 99.99  
**Default:** 0.00  
**See also:** d010, P034

Scales the time value when the drive is running at Minimum Freq (P034). When set to a value other than zero, Process Display (d010) indicates the duration of the process.

---

### A116 Process Time Hi

**Range:** 0.00 to 99.99  
**Default:** 0.00  
**See also:** d010, P035

Scales the time value when the drive is running at Maximum Freq (P035). When set to a value other than zero, Process Display (d010) indicates the duration of the process.

---

### A117 Bus Reg Mode

**Range:** 0 = Disabled  
1 = Enabled  
**Default:** 1 = Enabled  
**See also:** N/A

Disables the bus regulator.

---

### A118 Current Limit 2

**Range:** 0.1 to Drive Rated Amps x 1.8  
**Default:** Drive Rated Amps x 1.8  
**See also:** P033, A051-A054, A089

Maximum output current allowed before current limiting occurs. This parameter is only active if Digital Inx Sel (A051-A054) is set to 25 = Current Lmt2 and is active.

---

### A119 Skip Frequency

**Range:** 0 to 400 Hz  
**Default:** 0 Hz  
**See also:** A120

Sets the center of a frequency band at which the drive will not operate continuously (also called an avoidance frequency). A setting of 0 disables this parameter.

---

### A120 Skip Freq Band

**Range:** 0.0 to 30.0 Hz  
**Default:** 0.0 Hz  
**See also:** A119

Determines the bandwidth around Skip Frequency (A119); half the band above and half the band below the skip frequency. Refer to figure 9.12.



A setting of 0 disables this parameter.

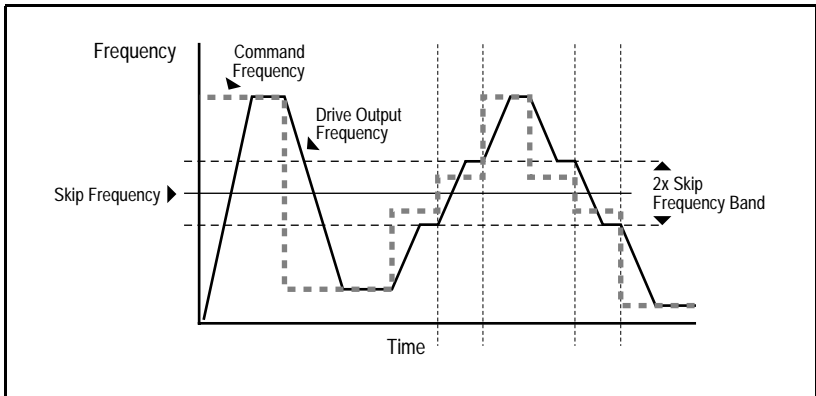

Figure 9.12 – Skip Freq Band (A120)

#### A121 Stall Fault Time

**Range:** 0 = 60 sec  
1 = 120 sec  
2 = 240 sec  
3 = 360 sec  
4 = 480 sec  
5 = Flt Disabled

**Default:** 0 = 60 sec

**See also:** A089-A118

Sets the time that the drive will remain in stall mode before a fault is issued.

#### A122 Analog In Loss

**Range:** 0 = Disabled  
1 = Fault (F29)  
2 = Stop  
3 = Zero Ref  
4 = Min Freq Ref  
5 = Max Freq Ref  
6 = Int Freq Ref

**Default:** 0 = Disabled

**See also:** A110, A111, A132

Selects the drive action when an input signal loss is detected. Signal loss is defined as an analog signal less than 1 V or 2 mA. The signal loss event ends and normal operation resumes when the input signal level is greater than or equal to 1.5 V or 3 mA. If using a 0-10 V analog input, set Anlg In 0-10V Lo (A110) to a minimum of 20% (i.e., 2 V).

**1 = Fault (F29):** F29 Analog Input Loss.

**2 = Stop:** Uses Stop Mode (P037).

**3 = Zero Ref:** Drive runs at zero speed reference.

**4 = Min Freq Ref:** Drive runs at minimum frequency.

**5 = Max Freq Ref:** Drive runs at maximum frequency.

**6 = Int Freq Ref:** Drive runs at internal frequency.

---

### A123 10V Bipolar Enbl

**Range:** 0 = Uni-Polar In (0 to 10 V only)  
1 = Bi-Polar In (+/-10 V)

**Default:** 0 = Uni-Polar In

**See also:** P038, A111

Enables/disables bipolar control. In bipolar mode, direction is commanded by the sign of the reference.

---

### A124 Var PWM Disable



**Range:** 0 = Enabled  
1 = Disabled

**Default:** 0 = Enabled

**See also:** A091

Enables/disables a feature that varies the carrier frequency for the PWM output waveform defined by PWM Frequency (A091).

Disabling this feature when low frequency conditions exist may result in IGBT stress and nuisance tripping.

---

## A125 Torque Perf Mode



**Range:** 0 = V/Hz  
1 = Sensrls Vect

**Default:** 1 = Sensrls Vect

**See also:** A084, A085, A086, A087, A127

Enables/disables sensorless vector control operation.

---

## A126 Motor NP FLA

**Range:** 0.1 to (Drive Rated Amps x 2)

**Default:** Drive Rated Amps

**See also:** A127

Set to motor nameplate rated full load amps.

---

## A127 Autotune



**Range:** 0 = Ready/Idle  
1 = Static Tune  
2 = Rotate Tune

**Default:** 0 = Ready/Idle

**See also:** A125, A126, A128, A129

Provides an automatic method for setting IR Voltage Drop (A128) and Flux Current Ref (A129), which affect sensorless vector performance. Motor NP FLA (A126) must be set to the motor nameplate full load amps before running the Autotune procedure.

If the Autotune procedure fails, an F80 SVC Autotune fault is displayed.

**0 = Ready/Idle:** The parameter returns to this setting following a Static Tune or Rotate Tune.

**1 = Static Tune:** A temporary command that initiates a non-rotational motor stator resistance test for the best possible automatic setting of IR Voltage Drop (A128). A start command is required following the initiation of this setting. The parameter returns to 0 = Ready/Idle following the test, at which time another start transition is required to operate the drive in normal mode. Used when the motor cannot be uncoupled from the load.

**2 = Rotate Tune:** A temporary command that initiates a Static Tune followed by a rotational test for the best possible automatic setting of Flux Current Ref (A129). A start command is required following the initiation of this setting. The parameter returns to 0 = Ready/Idle following the test, at which time another start transition is required to operate the drive in normal mode.

**Important:** Used when the motor is uncoupled from the load. The results may not be valid if a load is coupled to the motor during this procedure.



**ATTENTION:** Rotation of the motor in an undesired direction can occur during this procedure. To guard against possible injury and/or equipment damage, it is recommended that the motor be disconnected from the load before proceeding.

---

### A128 IR Voltage Drop

**Range:** 0.0 to 230.0 VAC  
**Default:** Based on Drive Rating  
**See also:** A127

The value of volts dropped across the resistance of the motor stator.

---

### A129 Flux Current Ref

**Range:** 0.00 to Motor NP Volts (P031)  
**Default:** Based on Drive Rating  
**See also:** A127

The value of amps for full motor flux.

---

### A130 PID Trim Hi

**Range:** 0.0 to 400.0  
**Default:** 0.0  
**See also:** N/A

Sets the maximum positive value that is added to a PID reference when PID trim is used.

---

**A131 PID Trim Lo**

**Range:** 0.0 to 400.0  
**Default:** 0.0  
**See also:** N/A

Sets the minimum positive value that is added to a PID reference when PID trim is used.

---

**A132 PID Ref Select**

**Range:** 0 = PID Disabled  
1 = PID Setpoint  
2 = 0-10V Input  
3 = 4-20mA Input  
4 = Comm Port  
5 = Setpnt, Trim  
6 = 0-10V, Trim  
7 = 4-20mA, Trim  
8 = Comm, Trim  
**Default:** 0 = PID Disabled  
**See also:** P038, A122

Enables/Disables PID mode and selects the source of the PID reference.

---

**A133 PID Feedback Sel**

**Range:** 0 = 0-10V Input  
1 = 4-20mA Input  
2 = Comm Port  
**Default:** 0 = 0-10V Input  
**See also:** N/A

Selects the source of the PID feedback. When A133 = 0, the PID will not function with a bipolar input. Negative voltages are treated as 0 volts.

---

**A134 PID Prop Gain**

**Range:** 0.00 to 99.99  
**Default:** 0.00  
**See also:** N/A

Sets the value for the PID proportional component when the PID mode is enabled by PID Ref Select (A132).

---

**A135 PID Integ Time**

**Range:** 0.0 to 999.9 sec  
**Default:** 0.0 sec  
**See also:** N/A

Sets the value of the PID integral component when the PID mode is enabled by PID Ref Select (A132).

---

**A136 PID Diff Rate**

**Range:** 0.00 to 99.99 (1/sec)  
**Default:** 0.00 (1/sec)  
**See also:** N/A

Sets the value for the PID differential component when the PID mode is enabled by PID Ref Select (A132).

---

**A137 PID Setpoint**

**Range:** 0.0 to 100.0%  
**Default:** 0.0%  
**See also:** N/A

Provides an internal fixed value for the process setpoint when the PID mode is enabled by PID Ref Select (A132).

---

**A138 PID Deadband**

**Range:** 0.0 to 10.0%  
**Default:** 0.0%  
**See also:** N/A

Sets the lower limit of the PID output.

---

**A139 PID Preload**

**Range:** 0.0 to 400.0 Hz  
**Default:** 0.0 Hz  
**See also:** N/A

Sets the value used to preload the integral component on start or enable.

**A140 Stp Logic 0**  
**A141 Stp Logic 1**  
**A142 Stp Logic 2**  
**A143 Stp Logic 3**  
**A144 Stp Logic 4**  
**A145 Stp Logic 5**  
**A146 Stp Logic 6**  
**A147 Stp Logic 7**



**Range:** 0001 to bAFF  
**Default:** 00F1  
**See also:** P038, P039, Po40, A051-A054, A055, A058, A061, A067, A068, A070-A077, A150-A157

Parameters A140-A147 can be used to create a custom profile of frequency commands. Each “step” can be based on time, status of a logic input, or a combination of time and the status of a logic input. These parameters are only active if Speed Reference (P038) is set to 6 = Stp Logic.

Digits 0-3 for each parameter (Stp Logic x) must be programmed according to the desired profile. A logic input is established by setting a digital input, Digital Inx Sel (A051-A054), to 23 = Logic In1 and or 24 = Logic In2.

A time interval between steps can be programmed using Stp Logic Time x (A150-A157). See table 9.6 for related parameters.

The speed for any step is programmed using Preset Freq x (A070-A077).

Table 9.6 – Related Parameters for Stp Logic Parameters (A140-A147)

StepLogic™ Parameter (Active when P038 = 6 “Stp Logic”)	Related Preset Frequency Parameter (Can be activated independent of StepLogic™ Parameters)	Related StepLogic™ Time Parameter (Active when A140-A147 Digit 0 or 1 are set to 1, b, C, d or E)
A140 (Stp Logic 0)	A070 (Preset Freq 0)	A150 (Stp Logic Time 0)
A141 (Stp Logic 1)	A071 (Preset Freq 1)	A151 (Stp Logic Time 1)
A142 (Stp Logic 2)	A072 (Preset Freq 2)	A152 (Stp Logic Time 2)
A143 (Stp Logic 3)	A073 (Preset Freq 3)	A153 (Stp Logic Time 3)
A144 (Stp Logic 4)	A074 (Preset Freq 4)	A154 (Stp Logic Time 4)
A145 (Stp Logic 5)	A075 (Preset Freq 5)	A155 (Stp Logic Time 5)
A146 (Stp Logic 6)	A076 (Preset Freq 6)	A156 (Stp Logic Time 6)
A147 (Stp Logic 7)	A077 (Preset Freq 7)	A157 (Stp Logic Time 7)

## **How StepLogic™ Works**

The StepLogic™ sequence begins with a valid start command. A normal sequence always begins with Stp Logic 0 (A140).

### **Digit 0: Logic For Next Step**

This digit defines the logic for the next step. When the condition is met, the program advances to the next step. Step 0 follows Step 7. Example: Digit 0 is set 3. When “Logic In2” becomes active, the program advances to the next step.

### **Digit 1: Logic to Jump to a Different Step**

For all settings other than F, when the condition is met, the program overrides Digit 0 and jumps to the step defined by digit 2.

### **Digit 2: Different Step to Jump**

When the condition for digit 1 is met, the digit 2 setting determines the next step or to end the program.

### **Digit 3: Step Settings**

This digit defines what accel/decel profile the speed command will follow and the direction of the command for the current step. In addition, if a relay or opto output (parameters A055, A058, and A061) is set to 15 = StpLogic Out, this parameter can control the status of that output.

Any StepLogic™ parameter can be programmed to control a relay or opto output, but you cannot control different outputs based on the condition of different StepLogic™ commands.

## **StepLogic™ Settings**

The logic for each function is determined by the four digits for each StepLogic™ parameter. Figure 9.13 shows the available settings for each digit.



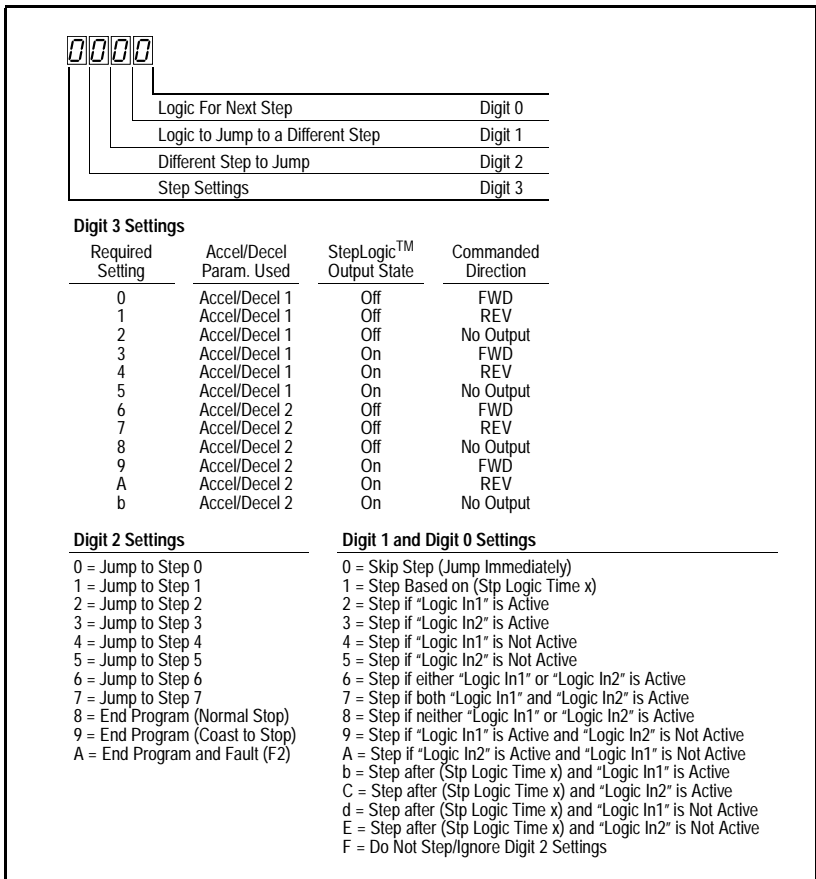

Figure 9.13 – Digit Settings

- A150 Stp Logic Time 0**
- A151 Stp Logic Time 1**
- A152 Stp Logic Time 2**
- A153 Stp Logic Time 3**
- A154 Stp Logic Time 4**
- A155 Stp Logic Time 5**
- A156 Stp Logic Time 6**
- A157 Stp Logic Time 7**

**Range:** 0.0 to 999.9 sec

**Default:** 30.0 sec

**See also:** P038, A055, A058, A061, A070-A077, A140-A147

Sets the time to remain in each step if the corresponding StpLogic command word is set to "Step after Time."

## A160 EM Brk Off Delay

**Range:** 0.01 to 10.00 sec

**Default:** 2.0 sec

**See also:** P037

Sets the time the drive remains at minimum frequency before the relay or an opto is energized and the drive ramps to the commanded frequency.

The relay or opto is typically connected to a user-supplied electromechanical brake coil relay. Set Stop Mode (P037) to 8 “Ramp+EM B,CF” or 9 “Ramp+EM Brk” to enable the electromechanical brake option.

Set Relay Out Sel (A055) and Opto Outx Sel (A058 or A061) to 22 “EM Brk Cntrl” to control brake operation.

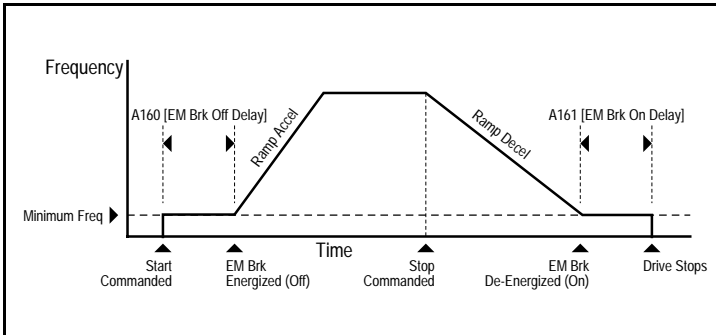

Figure 9.14 – EM BRK Off Delay

## A161 EM Brk On Delay

**Range:** 0.01 to 10.00 sec

**Default:** 2.0 sec

**See also:** P037

Sets the time the drive remains at minimum frequency before the relay or an opto output is de-energized and the drive stops.

The relay or opto output is typically connected to a user-supplied electromechanical brake coil relay. Set Stop Mode (P037) to 8 “Ramp+EM B,CF” or 9 “Ramp+EM Brk” to enable the electromechanical brake option.

Set Relay Out Sel (A055) and Opto Outx Sel (A058 or A061) to 22 “EM Brk Cntrl” to control brake operation.

---

## A162 MOP Reset Sel

**Range:** 0 = Zero MOP Ref  
1 = Save MOP Ref

**Default:** 1 = Save MOP Ref

**See also:** A069

Sets the drive to save the current MOP reference command.

**0 = Zero MOP Ref:** This option clamps Internal Freq (A069) at 0.0 Hz when the drive is not running.

**1 = Save MOP Ref:** Reference is saved in Internal Freq (A069).

## 9.3 Display Group Parameters

---

### d001 Output Freq

**Range:** 0.0 to Maximum Freq (P035)  
**Default:** Read Only  
**See also:** d002, d010, P034, P035, P038

Displays the output frequency present at terminals T1, T2, and T3 (U, V, and W).

---

### d002 Commanded Freq

**Range:** 0.0 to Maximum Freq (P035)  
**Default:** Read Only  
**See also:** d001, d013, P034, P035, P038

Displays the value of the active frequency command. The commanded frequency is displayed even if the drive is not running.

**Important:** The frequency command can come from a number of sources. Refer to section 6.6, Start and Speed Reference Control, for more information.

---

### d003 Output Current

**Range:** 0.00 to (Drive Rated Amps x 2)  
**Default:** Read Only  
**See also:** N/A

Displays the output current present at terminals T1, T2, and T3 (U, V, and W).

---

### d004 Output Voltage

**Range:** 0 to Drive Rated Volts  
**Default:** Read Only  
**See also:** P031, A084, A088

Displays the output voltage present at terminals T1, T2, and T3 (U, V, and W).

---

**d005 DC Bus Voltage**

**Range:** Based on Drive Rating  
**Default:** Read Only  
**See also:** N/A

Displays the present DC bus voltage level.

---

**d006 Drive Status**

**Range:** 0 = Condition False  
1 = Condition True  
See figure 9.15  
**Default:** Read Only  
**See also:** A095

Displays the present operating status of the drive.

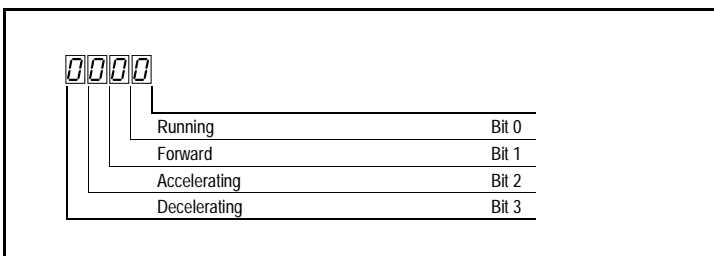

Figure 9.15 – Drive Status (d006) Bit Definitions

---

**d007 Fault 1 Code**  
**d008 Fault 2 Code**  
**d009 Fault 3 Code**

**Range:** F2 to F122  
**Default:** Read Only  
**See also:** N/A

Displays a code that represents a drive fault. The codes will appear in these parameters in the order they occur (that is, Fault 1 Code in d007 will contain the more recent fault). Repetitive faults will be recorded only once. Refer to chapter 10 for the fault code descriptions.

## d010 Process Display

32

**Range:** 0.00 to 9999  
**Default:** Read Only  
**See also:** d001, A099

Displays the output frequency scaled by Process Factor (A099).

Output Frequency x Process Factor = Process Display

## d012 Control Source

**Range:** 0 to 9  
See figure 9.16.  
**Default:** Read Only  
**See also:** P036, P038, A051-A054

Displays the active source of the Start Command and Speed Command, which are normally defined by the settings of Start Source (P036) and Speed Reference (P038) but may be overridden by digital inputs. Refer to the flowcharts in sections 6.6 and 6.7 for details.

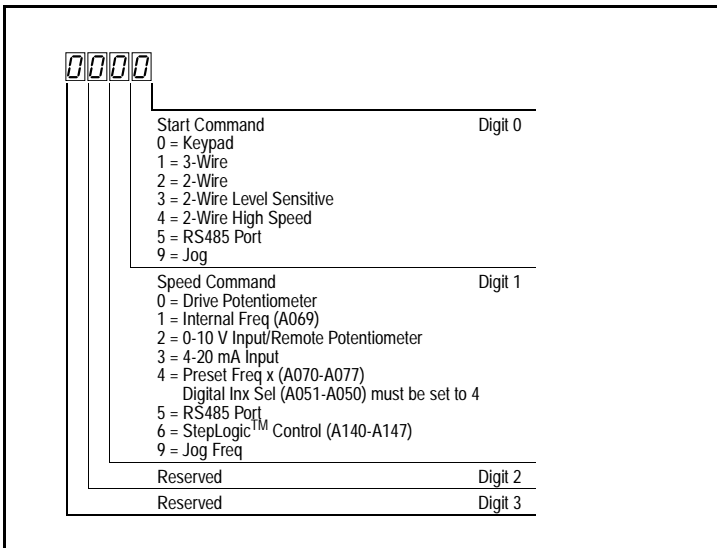

Figure 9.16 – Control Source (d012) Bit Definitions

## d013 Contrl In Status

**Range:** 0 = Input Present  
1 = Input Not Present  
See figure 9.17

**Default:** Read Only

**See also:** d002, P034, P035

Displays the status of the control terminal block control inputs.

**Important:** Actual control commands may come from a source other than the control terminal block.

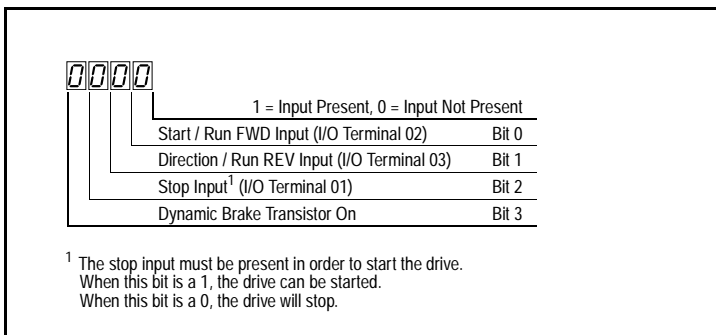

Figure 9.17 – Contrl In Status (d013) Bit Definitions

## d014 Dig In Status

**Range:** 0 = Input Not Present  
1 = Input Present  
See figure 9.18.

**Default:** Read Only

**See also:** A051-A054

Displays the status of the control terminal block digital inputs.

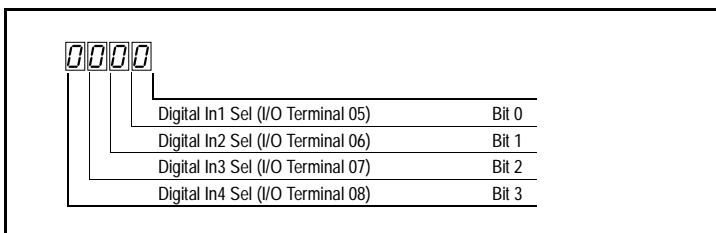

Figure 9.18 – Dig In Status (d014) Bit Definitions

---

## d015 Comm Status

**Range:** 0 = Condition False  
1 = Condition True  
See figure 9.19.

**Default:** Read Only

**See also:** A103 through A107

Displays the status of the communications ports.

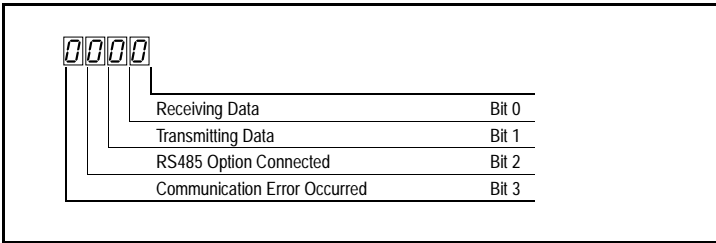

Figure 9.19 – Comm Status (d015) Bit Definitions

---

## d016 Control SW Ver

**Range:** 1.00 to 99.99

**Default:** Read Only

**See also:** N/A

Displays the Main Control Board software version.

---

## d017 Drive Type

**Range:** 1001 to 9999

**Default:** Read Only

**See also:** N/A

Used by Rockwell Automation field service personnel.

---

## d018 Elapsed Run Time

**Range:** 0 to 9999 Hours

**Default:** Read Only

**See also:** N/A

Displays the accumulated time drive is outputting power. The time is displayed in 10-hour increments (that is, 1 = 10 hours).



---

**d019 Testpoint Data**

**Range:** 0 to FFFF

**Default:** Read Only

**See also:** A102

Displays the present value of the function selected in Testpoint Select (A102).

---

**d020 Analog In 0-10V**

**Range:** 0.0 to 100.0%

**Default:** Read Only

**See also:** A110, A111

Displays the present value of the voltage at I/O Terminal 13 (100.0% = 10 V).

---

**d021 Analog In 4-20mA**

**Range:** 0.0 to 100.0%

**Default:** Read Only

**See also:** A112, A113

Displays the present value of the current at I/O Terminal 15 (0.0% = 4 mA, 100.0% = 20 mA).

---

**d022 Output Power**

**Range:** 0.00 to (Drive Rated Power x 2)

**Default:** Read Only

**See also:** N/A

Displays the output power present at T1, T2, and T3, (U, V, and W).

---

**d023 Output Powr Fctr**

**Range:** 0.0 to 180.0 deg

**Default:** Read Only

**See also:** N/A

Displays the angle in electrical degrees between motor voltage and motor current.

---

## d024 Drive Temp

**Range:** 0 to 120 degree C

**Default:** Read Only

**See also:** N/A

Displays the present operating temperature of the drive power section.

---

## d025 Counter Status

**Range:** 0 to 9999

**Default:** Read Only

**See also:** N/A

Displays the current value of the counter when the counter is enabled.

---

## d026 Timer Status



**Range:** 0.0 to 9999 seconds

**Default:** Read Only

**See also:** N/A

Displays the current value of the timer when the timer is enabled.

---

## d028 Stp Logic Status

**Range:** 0 to 7

**Default:** Read Only

**See also:** N/A

When Speed Reference (P038) is set to 6 = Stp Logic, this parameter displays the current step of the StepLogic™ profile as defined by parameters Stp Logic x (A140-A147).

---

## d029 Output Torque Current

**Range:** 0.00 to (Drive Rated Amps x 2)

**Default:** Read Only

**See also:** N/A

Displays the current value of the motor torque current as measured by the drive.

## Troubleshooting the Drive



**ATTENTION:** The drive contains high voltage capacitors that take time to discharge after removal of mains supply. Before working on the drive, ensure isolation of mains supply from line inputs [R, S, T (L1, L2, L3)]. Wait three (3) minutes for capacitors to discharge to safe voltage levels. Darkened display LEDs is not an indication that capacitors have discharged to safe voltage levels. Failure to observe this precaution could result in severe bodily injury or loss of life.

**ATTENTION:** Only qualified electrical personnel familiar with the construction and operation of this equipment and the hazards involved should install, adjust, operate, or service this equipment. Read and understand this manual and other applicable manuals in their entirety before proceeding. Failure to observe this precaution could result in severe bodily injury or loss of life.

The MD65 constantly monitors its status and provides the following ways to determine the status of the drive and to troubleshoot problems that may occur:

- LEDs on the drive (refer to figure 8.1 and table 8.1 for a description of the LEDs)
- Fault codes

### 10.1 Fault Codes

Faults codes indicate conditions within the drive that require immediate attention. The drive responds to a fault by initiating a coast-to-stop sequence and turning off output power to the motor.

The integral keypad provides visual notification of a fault condition by displaying the following:

- Flashing fault number (code) on the display. (See table 10.1 for the fault code descriptions.)
- Flashing FAULT LED

In addition, parameters d007-d009 act as a fault log. See the parameter descriptions in chapter 9 for more information.

## 10.1.1 Manually Clearing Faults

- Step 1. Note the number of the fault code flashing on the display.
- Step 2. Address the condition that caused the fault. Refer to table 10.1 for a description of the fault and corrective actions. The cause must be corrected before the fault can be cleared.
- Step 3. After corrective action has been taken, clear the fault and reset the drive using one of the following methods:
  - Press  if P037 (Stop Mode) is set to a value between 0 and 3.
  - Cycle drive power.
  - Set A100 (Fault Clear) to 1.
  - Cycle digital input if A051-A054 (Digital Inx Sel) is set to 7 = Clear Fault.

## 10.1.2 Automatically Clearing Faults (Auto Restart Feature)

The Auto Restart feature provides the ability for the drive to automatically perform a fault reset followed by a start attempt without user or application intervention. This allows remote or “unattended” operation. This feature can only be used for auto-resettable faults (see table 10.1).

When this type of fault occurs, and Auto Rstrt Tries (A092) is set to a value greater than 0, a user-configurable timer, Auto Rstrt Delay (A093), begins. When the timer reaches zero, the drive attempts to automatically reset the fault. If the condition that caused the fault is no longer present, the fault will be reset and the drive will be restarted.

### **To automatically clear an auto-resettable fault and restart the drive:**

- Step 1. Set A092 (Auto Rstrt Tries) to a value other than 0.
- Step 2. Set A093 (Auto Rstrt Delay) to a value other than 0.

### **To automatically clear an OverVoltage, UnderVoltage, or Heatsink OverTemp fault without restarting the drive:**

- Step 1. Set A092 (Auto Rstrt Tries) to a value other than 0.
- Step 2. Set A093 (Auto Rstrt Delay) to 0.

Use caution when enabling this feature since the drive will attempt to issue its own start command based on user-selected programming.

Table 10.1 – Fault Descriptions and Corrective Actions

No.	Fault	Auto-Reset <sup>1</sup> ?	Description	Action
F2	Auxiliary Input	Y	Auxiliary input interlock is open.	<ul style="list-style-type: none"> <li>• Check remote wiring.</li> <li>• Verify communications programming for intentional fault.</li> </ul>
F3	Power Loss	N	DC bus voltage remained below 85% of nominal.	<ul style="list-style-type: none"> <li>• Monitor the incoming AC line for low voltage or line power interruption.</li> <li>• Check input fuses.</li> </ul>
F4	UnderVoltage	Y	DC bus voltage fell below the minimum value.	Monitor the incoming AC line for low voltage or line power interruption.
F5	OverVoltage	Y	DC bus voltage exceeded maximum value.	Monitor the AC line for high line voltage or transient conditions. Bus overvoltage can also be caused by motor regeneration. Extend the decel time or install dynamic brake option.
F6	Motor Stalled	Y	Drive is unable to accelerate motor.	Increase Accel Time x (P039, A067) or reduce load so drive output current does not exceed the current set by parameter A089 (Current Limit 1).
F7	Motor Overload	Y	Internal electronic overload trip.	<ul style="list-style-type: none"> <li>• An excessive motor load exists. Reduce load so drive output current does not exceed the current set by parameter P033 (Motor OL Current).</li> <li>• Verify Boost Select (A084) setting.</li> </ul>

Table 10.1 – Fault Descriptions and Corrective Actions (Continued)

No.	Fault	Auto-Reset <sup>1</sup> ?	Description	Action
F8	Heatsink OverTemp	Y	Heatsink temperature exceeds a predefined value.	<ul style="list-style-type: none"> <li>• Check for blocked or dirty heat sink fins. Verify that ambient temperature has not exceeded 40°C (104°F) for IP 30/NEMA 1/UL Type 1 installations or 50°C (122°F) for Open type installations.</li> <li>• Check fan.</li> </ul>
F12	HW OverCurrent	N	The drive output current has exceeded the hardware current limit.	Check programming. Check for excess load, improper Boost Select (A084) setting, DC brake volts set too high, or other causes of excess current.
F13	Ground Fault	N	A current path to earth ground has been detected at one or more of the drive output terminals.	Check the motor and external wiring to the drive output terminals for a grounded condition.
F29	Analog Input Loss	Y	An analog input is configured to fault on signal loss. A signal loss has occurred. Configure with Analog In Loss (A122).	<ul style="list-style-type: none"> <li>• Check parameters.</li> <li>• Check for broken/loose connections at inputs.</li> </ul>
F33	Auto Rstrt Tries	N	Drive unsuccessfully attempted to reset a fault and resume running for the programmed number of Auto Rstrt Tries (A092).	Correct the cause of the fault and manually clear.
F38	Phase U to Gnd	N	A phase to ground fault has been detected between the drive and motor in this phase.	<ul style="list-style-type: none"> <li>• Check the wiring between the drive and motor.</li> <li>• Check motor for grounded phase.</li> <li>• Replace drive if fault cannot be cleared.</li> </ul>
F39	Phase V to Gnd			
F40	Phase W to Gnd			

Table 10.1 – Fault Descriptions and Corrective Actions (Continued)

No.	Fault	Auto-Reset <sup>1</sup> ?	Description	Action
F41	Phase UV Short	N	Excessive current has been detected between these two output terminals.	<ul style="list-style-type: none"> <li>• Check the motor and drive output terminal wiring for a shorted condition.</li> <li>• Replace drive if fault cannot be cleared.</li> </ul>
F42	Phase UW Short			
F43	Phase VW Short			
F48	Params Defaulted	N	The drive was commanded to write default values to EEPROM.	<ul style="list-style-type: none"> <li>• Clear the fault or cycle power to the drive.</li> <li>• Program the drive parameters as needed.</li> </ul>
F63	SW OverCurrent	Y	Programmed SW Current Trip (A098) has been exceeded.	Check load requirements and SW Current Trip (A098) setting.
F64	Drive Overload	N	Drive rating of 150% for 1 minute or 200% for 3 seconds has been exceeded.	Reduce load or extend Accel Time.
F70	Power Unit	N	Failure has been detected in the drive power section.	<ul style="list-style-type: none"> <li>• Cycle power.</li> <li>• Replace drive if fault cannot be cleared.</li> </ul>
F80	SVC Autotune	N	The Autotune function was either cancelled by the user or failed.	Restart procedure.
F81	Comm Loss	N	RS485 port stopped communicating.	<ul style="list-style-type: none"> <li>• If module was not intentionally disconnected, check wiring to the port. Replace wiring, port expander, module, or complete drive as required.</li> <li>• Check connection.</li> <li>• A module was intentionally disconnected.</li> <li>• Turn off using Comm Loss Action (A105).</li> </ul>

Table 10.1 – Fault Descriptions and Corrective Actions (Continued)

<b>No.</b>	<b>Fault</b>	<b>Auto-Reset<sup>1</sup>?</b>	<b>Description</b>	<b>Action</b>
F100	Parameter Checksum	N	The checksum read from the board does not match the checksum calculated.	Set Reset to Defaults (P041) to 1 = Reset Defaults.
F122	I/O Board Fail	N	Failure has been detected in the drive control and I/O section.	<ul style="list-style-type: none"> <li>• Cycle power.</li> <li>• Replace drive if fault cannot be cleared.</li> </ul>

<sup>1</sup> Refer to section 10.1.2 for information about the Auto Restart Feature.



## 10.2 Troubleshooting Tables

Use the following tables to troubleshoot the drive. If you cannot resolve the problem using these tables, contact Reliance Electric.

### 10.2.1 Problem: Drive Does Not Start From Terminal Block Start or Run Inputs

Table 10.2 – Problem: Drive Does Not Start From Terminal Block Start or Run Inputs

Possible Cause(s)	Indication	Corrective Action
Drive is faulted	Flashing red FAULT LED	Clear fault by using one of the following methods: <ul style="list-style-type: none"><li>• Press Stop</li><li>• Cycle power</li><li>• Set Fault Clear (A100) to 1 = Clear Faults</li><li>• Cycle digital input if Digital Inx Sel (A051-A054) is set to 7 = Clear Fault</li></ul>
Incorrect programming. <ul style="list-style-type: none"><li>• Start Source (P036) is set to 0 = Keypad or 5 = RS485 Port.</li><li>• Digital Inx Sel (A051-A054) is set to 5 = Local and the input is active.</li></ul>	None	Check parameter settings.
Incorrect input wiring. See section 6.4.1 for wiring examples. <ul style="list-style-type: none"><li>• 2-wire control requires Run Forward, Run Reverse or Jog input.</li><li>• 3-wire control requires Start and Stop inputs</li><li>• Stop input is always required.</li></ul>	None	Wire inputs correctly and/or install jumper.
Incorrect Sink/Source DIP switch setting.	None	Set switch to match wiring scheme.

## 10.2.2 Problem: Drive Does Not Start From Integral Keypad

Table 10.3 – Problem: Drive Does Not Start From Integral Keypad

Cause(s)	Indication	Corrective Action
Integral keypad is not enabled.	Start Key Status LED is not on.	<ul style="list-style-type: none"> <li>• Set Start Source (P036) to 0 = Keypad.</li> <li>• Set Digital Inx Sel (A051 to A054) to 5 = Local and activate the input.</li> </ul>
I/O Terminal 01 "Stop" input is not present.	None	Wire inputs correctly and/or install jumper.

## 10.2.3 Problem: Drive Does Not Respond to Changes in Speed Command

Table 10.4 – Problem: Drive Does Not Respond to Changes in Speed Command

Cause(s)	Indication	Corrective Action
No value is coming from the source of the command.	The RUN LED is on and output is 0 Hz.	<ul style="list-style-type: none"> <li>• Check Control Source (d012) for correct source.</li> <li>• If the source is an analog input, check wiring and use a meter to check for presence of signal.</li> <li>• Check Commanded Frequency (d002) to verify correct command.</li> </ul>
Incorrect reference source is being selected via remote device or digital inputs.	None	<ul style="list-style-type: none"> <li>• Check Control Source (d012) for correct source.</li> <li>• Check Digital Input Status (d014) to see if inputs are selecting an alternate source. Verify settings for Digital Inx Sel (A051-A054).</li> <li>• Check Speed Reference (P038) for the source of the speed reference. Reprogram as necessary.</li> <li>• Review the Speed Reference Control chart in figure 6.2.</li> </ul>

## 10.2.4 Problem: Motor Does Not Start

Cause(s)	Indication	Corrective Action
No output voltage to the motor.	None	<p>Check the power circuit.</p> <ul style="list-style-type: none"> <li>• Check the supply voltage.</li> <li>• Check all the fuses and disconnects.</li> </ul> <p>Check the motor.</p> <ul style="list-style-type: none"> <li>• Verify that the motor is connected properly.</li> </ul> <p>Check the control input signals</p> <ul style="list-style-type: none"> <li>• Verify that a Start signal is present. If 2-Wire control is used, verify that either the Run Forward or Run Reverse signal is active, but not both.</li> <li>• Verify that I/O Terminal 01 is active.</li> <li>• Verify that Start Source (P036) matches your configuration.</li> <li>• Verify that Reverse Disable (A095) is not prohibiting movement.</li> </ul>
Drive is faulted.	Flashing red STATUS LED.	<p>Clear fault.</p> <ul style="list-style-type: none"> <li>• Press Stop</li> <li>• Cycle power</li> <li>• Set Fault Clear (A100) to 1 = Clear Faults.</li> <li>• Cycle digital input if Digital Inx Sel (A051-A054) is set to 7 = Clear Fault.</li> </ul>

## 10.2.5 Problem: Motor and/or Drive Will Not Accelerate to Commanded Speed

Table 10.5 – Problem: Motor and/or Drive Will Not Accelerate to Commanded Speed

Cause(s)	Indication	Corrective Action
Acceleration time is excessive.	None	Reprogram P039 (Accel Time 1) or A067 (Accel Time 2).
Excess load or short acceleration times force the drive into current limit, slowing or stopping acceleration.	None	<ul style="list-style-type: none"> <li>• Compare Output Current (d003) with Current Limit (A089).</li> <li>• Remove excess load or reprogram Accel Time 1 (P039) or Accel Time 2 (A067).</li> <li>• Check for improper Boost Select (A084) setting.</li> </ul>
Speed command source or value is not as expected.	None	<ul style="list-style-type: none"> <li>• Verify Commanded Freq (d002).</li> <li>• Check Control Source (d012) for the proper Speed Command.</li> </ul>
Programming is preventing the drive output from exceeding limiting values.	None	Check Maximum Freq (P035) to ensure that speed is not limited by programming.
Torque performance does not match motor characteristics.	None	<ul style="list-style-type: none"> <li>• Set motor nameplate full load amps in Motor NP FLA (A126).</li> <li>• Perform Autotune procedure (A127 = Static Tune or Rotate Tune).</li> <li>• Set Torque Perf Mode (A125) to 0 = V/Hz.</li> </ul>

## 10.2.6 Problem: Motor Operation is Unstable

Table 10.6 – Problem: Motor Operation is Unstable

Cause(s)	Indication	Corrective Action
Motor data was incorrectly entered.	None	<ol style="list-style-type: none"> <li>1. Correctly enter motor nameplate data into P031, P032, and P033.</li> <li>2. Enable Compensation (A097).</li> <li>3. Use Boost Select (A084) to reduce boost level.</li> </ol>

## 10.2.7 Problem: Drive Will Not Reverse Motor Direction.

Table 10.7 – Problem: Drive Will Not Reverse Motor Direction

<b>Cause(s)</b>	<b>Indication</b>	<b>Corrective Action</b>
Digital input is not selected for reversing control.	None	Check Digital Inx Sel. Choose correct input and program for reversing mode.
Digital input is incorrectly wired.	None	Check input wiring.
Motor wiring is improperly phased for reverse.	None	Switch two motor leads.
Reverse is disabled.	None	Check Reverse Disable (A095).

## 10.2.8 Problem: Drive Does Not Power Up

<b>Cause(s)</b>	<b>Indication</b>	<b>Corrective Action</b>
No input power to the drive.	None	Check the power circuit. <ul style="list-style-type: none"> <li>• Check the supply voltage.</li> <li>• Check all fuses and disconnects.</li> </ul>
Jumper between I/O Terminals P2 and P1 not installed and/or DC Bus Inductor not connected.	None	Install jumper or connect DC Bus Inductor.





# APPENDIX A

## Technical Specifications

<b>Environment</b>	
Altitude:	1000 m (3300 ft) maximum without derating
Ambient Operating Temperature:	Open Type, IP 20: -10° C (14° F) to 50° C (122° F) NEMA 1, IP30, UL Type 1: -10° C (14° F) to 40° C (104° F)
Storage Temperature (all const.):	-40° C (-40° F) to 85° C (185° F)
Cooling Method:	0.5 HP drives: Convection 1 HP and above: Fan
Relative Humidity:	0% to 95%, non-condensing
Atmosphere:	<b>Important:</b> The drive must not be installed in an area where the ambient atmosphere contains volatile or corrosive gas, vapors, or dust. If the drive is not going to be installed for a period of time, it must be stored in an area where it will not be exposed to a corrosive atmosphere.
Shock (Operating):	15 G peak for 11 ms duration (+/-1.0 ms)
Vibration (Operating):	1 G peak, 5 to 2000 Hz
<b>Control</b>	
Carrier Frequency:	2-16 kHz. Drive rating based on 4 kHz.
Frequency Accuracy	<ul style="list-style-type: none"><li>• Digital Input: Within +/-0.05% of set output frequency.</li><li>• Analog Input: Within 0.5% of maximum output frequency. 10-bit resolution.</li><li>• Analog Output: +/-2% of full scale. 10-bit resolution.</li></ul>
Speed Regulation - Open Loop with Slip Compensation:	+/-1% of base speed across a 60:1 speed range.
Stop Modes:	Multiple programmable stop modes including: Ramp, Coast, DC-Brake, Ramp-to-Hold, S Curve, and Dynamic Braking (1 HP and above)..

Accel/Decel:	Two independently programmable accel and decel times. Each time may be programmed from 0-600 seconds in 0.1 second increments.
Intermittent Overload:	<ul style="list-style-type: none"> <li>• 150% Overload capability for up to 1 minute.</li> <li>• 200% Overload capacity for up to 3 seconds</li> </ul>
Electronic Motor Overload Protection:	Class 10 protection with speed-sensitive response.
<b>Input/Output Rating</b>	
Output Frequency:	0-400 Hz (Programmable)
Efficiency:	97.5% (Typical)
<b>Digital Control Inputs (Inputs Current = 6 mA)</b>	
SRC (Source) Mode:	18-24 V = ON 0-6 V = OFF
SNK (Sink) Mode:	0-6 V = ON 18-24 V = OFF
<b>Analog Control Inputs</b>	
4-20 mA Analog:	250 ohm input impedance
0-10 V DC Analog:	100k ohm input impedance
External Pot:	1-10 k ohm, 2 Watt minimum
<b>Control Output</b>	
Programmable Output (form C relay)	
Resistive Rating:	3.0 A at 30 V DC, 3.0 A at 125 V AC, 3.0 A at 240 V AC
Inductive Rating:	0.5 A at 30 V DC, 0.5 A at 125 V AC, 0.5 A
Opto Outputs	
Resistive Rating:	30 V DC, 50 mA
Inductive Rating:	Recover diode. Refer to figure 6.1 for details.
Analog Outputs (10-bit)	
Rating:	0-10 V, 1k ohm min. 4-20 mA, 525 ohm max
<b>Fuses and Circuit Breakers</b>	
Recommended Fuse Type:	UL Class J, CC, T or Type BS88; 600 V (550 V) or equivalent.
Recommended Circuit Breakers:	HMCP circuit breakers or equivalent.



<b>Protective Features</b>	
Motor Protection:	Programmable $I^2t$ overload protection provides Class 10 protection. See parameter P033.
Overcurrent:	200% hardware limit, 300% instantaneous fault
Over Voltage:	<ul style="list-style-type: none"> <li>• 100-120 V AC Input – Trip occurs at 405 V DC bus voltage (equivalent to 150 V AC incoming line)</li> <li>• 200-240 V AC Input – Trip occurs at 405 V DC bus voltage (equivalent to 290 V AC incoming line)</li> <li>• 380-460 V AC Input – Trip occurs at 810 V DC bus voltage (equivalent to 575 V AC incoming line)</li> <li>• 460-600 V AC Input – Trip occurs at 1005 V DC bus voltage (equivalent to 711 V AC incoming line)</li> </ul>
Under Voltage:	<ul style="list-style-type: none"> <li>• 100-120 V AC Input – Trip occurs at 210 V DC bus voltage (equivalent to 75 V AC incoming line)</li> <li>• 200-240 V AC Input – Trip occurs at 210 V DC bus voltage (equivalent to 150 V AC incoming line)</li> <li>• 380-480 V AC Input – Trip occurs at 390 V DC bus voltage (equivalent to 275 V AC incoming line)</li> <li>• 460-600 V AC Input – <ul style="list-style-type: none"> <li>• If P042=3 “High Voltage” trip occurs at 487 V DC bus voltage (equivalent to 344 V AC incoming line)</li> <li>• If P042=2 “Low Voltage” trip occurs at 390 V DC bus voltage (equivalent to 275 V AC incoming line)</li> </ul> </li> </ul>
Control Ride-Through:	Minimum ride-through is 0.5 sec - typical value 2 sec
Faultless Power Ride-Through:	100 milliseconds
<b>Dynamic Braking</b>	
Internal brake IGBT included with all ratings 0.75 kW (1 HP) and larger.	
<b>Approvals</b>	
   EMC Directive 89/336 LV: EN 50178, EN 60204 EMC: EN 61800-3, EN 50081-1, EN 50082-2	



# APPENDIX B

## Record of User Settings

### B.1 Basic Parameter Group

No.	Parameter Name	Default Value	Page No.	User Setting
P031	Motor NP Volts	Varies	9-2	
P032	Motor NP Hertz	60 Hz	9-2	
P033	Motor OL Current	Varies	9-2	
P034	Minimum Freq	0.0 Hz	9-2	
P035	Maximum Freq	60 Hz	9-2	
P036	Start Source	0 = Keypad	9-3	
P037	Stop Mode	1 = Coast, CF	9-4	
P038	Speed Reference	0 = Drive Pot	9-5	
P039	Accel Time 1	5.0 sec	9-6	
P040	Decel Time 1	5.0 sec	9-6	
P041	Reset to Defaults	0 = Read/Idle	9-7	
P042	Voltage Class	3 = "High Voltage" 600 V	9-7	

## B.2 Advanced Parameter Group

No.	Parameter Name	Default Value	Page No.	User Setting
A051	Digital In1 Sel	4 = Preset Freq	9-8	
A052	Digital In2 Sel	4 = Preset Freq	9-8	
A053	Digital In3 Sel	4 = Preset Freq	9-8	
A054	Digital In4 Sel	5 = Local	9-8	
A055	Relay Out Sel	0 = Ready/Fault	9-11	
A056	Relay Out Level	0.0	9-13	
A058	Opto Out1 Sel	0 = Ready/Fault	9-14	
A059	Opto Out1 Level	0.0	9-16	
A061	Opto Out2 Sel	2 = Motor Running	9-14	
A062	Opto Out2 Level	0.0	9-16	
A064	Opto Out Logic	0	9-16	
A065	Analog Out Sel	0	9-17	
A066	Analog Out High	100%	9-18	
A067	Accel Time 2	10.0 sec	9-18	
A068	Decel Time 2	10.0 sec	9-18	
A069	Internal Freq	0.0 Hz	9-19	
A070	Preset Freq 0	0.0 Hz	9-20	
A071	Preset Freq 1	0.0 Hz	9-20	
A072	Preset Freq 2	0.0 Hz	9-20	
A073	Preset Freq 3	0.0 Hz	9-20	
A074	Preset Freq 4	0.0 Hz	9-20	
A075	Preset Freq 5	0.0 Hz	9-20	
A076	Preset Freq 6	0.0 Hz	9-20	
A077	Preset Freq 7	0.0 Hz	9-20	
A078	Jog Frequency	10.0 Hz	9-20	
A079	Jog Accel/Decel	10.0 sec	9-21	
A080	DC Brake Time	0.0 sec	9-21	
A081	DC Brake Level	Drive Rated Amps x 0.5	9-21	
A082	DB Resistor Sel	0 = Disabled	9-22	
A083	S Curve%	0% (Disabled)	9-22	

<b>No.</b>	<b>Parameter Name</b>	<b>Default Value</b>	<b>Page No.</b>	<b>User Setting</b>
A084	Boost Select	8 = 5.0, CT 7 = 2.5, CT (for 5.0, 7.5, and 10.0 HP drives only)	9-23	
A085	Start Boost	5.0%	9-24	
A086	Break Voltage	25.0%	9-24	
A087	Break Frequency	15.0 Hz	9-25	
A088	Maximum Voltage	Drive Rated Volts	9-25	
A089	Current Limit 1	Drive Rated Amps x 1.8	9-25	
A090	Motor OL Select	0 = No Derate	9-25	
A091	PWM Frequency	4.0 kHz	9-26	
A092	Auto Rstrt Tries	0	9-26	
A093	Auto Rstrt Delay	1.0 sec	9-27	
A094	Start At PowerUp	0 = Disabled	9-27	
A095	Reverse Disable	0 = Rev Enabled	9-27	
A096	Flying Start En	0 = Disabled	9-28	
A097	Compensation	1 = Electrical	9-28	
A098	SW Current Trip	0.0 (Disabled)	9-28	
A099	Process Factor	30.0	9-29	
A100	Fault Clear	0 = Ready/Idle	9-29	
A101	Program Lock	0 = Unlocked	9-29	
A102	Testpoint Sel	400	9-29	
A103	Comm Data Rate	4 = 19.2 K	9-30	
A104	Comm Node Addr	1	9-30	
A105	Comm Loss Action	0 = Fault	9-30	
A106	Comm Loss Time	5.0 sec	9-31	
A107	Comm Format	0 = RTU 8-N-1	9-31	
A108	Language	1 = English	9-31	
A109	Anlg Out Setpoint	0.0%	9-32	
A110	Anlg In 1-10V Lo	0.0%	9-32	
A111	Anlg In 0-10V Hi	100.0%	9-32	
A112	Anlg In4-20mA Lo	0.0%	9-32	
A113	Anlg In4-20mA Hi	100.0%	9-33	
A114	Slip Hertz @ FLA	2.0 Hz	9-33	

<b>No.</b>	<b>Parameter Name</b>	<b>Default Value</b>	<b>Page No.</b>	<b>User Setting</b>
A115	Process Time Lo	0.00	9-33	
A116	Process Time Hi	0.00	9-34	
A117	Bus Reg Mode	1 = Enabled	9-34	
A118	Current Limit 2	Drive Rated Amps x 1.8	9-33	
A119	Skip Frequency	0 Hz	9-34	
A120	Skip Freq Band	0.0 Hz	9-34	
A121	Stall Fault Time	0 = 60 sec	9-35	
A122	Analog In Loss	0 = Disabled	9-35	
A123	10V Bipolar Enbl	0 = Uni-Polar In	9-36	
A124	Var PWM Disable	0 = Enabled	9-36	
A125	Torque Perf Mode	1 = Sensrls Vect	9-37	
A126	Motor NP FLA	Drive Rated Amps	9-37	
A127	Autotune	0 = Ready/Idle	9-37	
A128	IR Voltage Drop	Based on Drive Rating	9-38	
A129	Flux Current Ref	Based on Drive Rating	9-38	
A130	PID Trim Hi	0.0	9-38	
A131	PID Trim Lo	0.0	9-39	
A132	PID Ref Select	0 = PID Disabled	9-39	
A133	PID Feedback Sel	0 = 0-10V Input	9-39	
A134	PID Prop Gain	0.00	9-39	
A135	PID Integ Time	0.0 sec	9-40	
A136	PID Diff Rate	0.0 (1/sec)	9-40	
A137	PID Setpoint	0.0%	9-40	
A138	PID Deadband	0.0%	9-40	
A139	PID Preload	0.0 Hz	9-40	
A140	Stp Logic 0	00F1	9-41	
A141	Stp Logic 1	00F1	9-41	
A142	Stp Logic 2	00F1	9-41	
A143	Stp Logic 3	00F1	9-41	
A144	Stp Logic 4	00F1	9-41	
A145	Stp Logic 5	00F1	9-41	
A146	Stp Logic 6	00F1	9-41	
A147	Stp Logic 7	00F1	9-41	

<b>No.</b>	<b>Parameter Name</b>	<b>Default Value</b>	<b>Page No.</b>	<b>User Setting</b>
A150	Stp Logic Time 0	30.0 sec	9-43	
A151	Stp Logic Time 1	30.0 sec	9-43	
A152	Stp Logic Time 2	30.0 sec	9-43	
A153	Stp Logic Time 3	30.0 sec	9-43	
A154	Stp Logic Time 4	30.0 sec	9-43	
A155	Stp Logic Time 5	30.0 sec	9-43	
A156	Stp Logic Time 6	30.0 sec	9-43	
A157	Stp Logic Time 7	30.0 sec	9-43	
A160	Em Brk Off Delay	2.0 sec	9-44	
A161	Em Brk On Delay	2.0 sec	9-44	
A162	MOP Reset Sel	1 = Save Mop Ref	9-45	





# APPENDIX C

## Parameters Cross-Referenced by Name

Parameter Name	No.	Parameter Group	Default Value	Page No.
10V Bipolar Enbl	A123	Advanced	0 = Uni-Polar In	9-36
Accel Time 1	P039	Basic	5.0 sec	9-6
Accel Time 2	A067	Advanced	10.0 sec	9-18
Analog In 0-10V	d020	Display	Read Only	9-51
Analog In 4-20mA	d021	Display	Read Only	9-51
Analog In Loss	A122	Advanced	0 = Disabled	9-35
Analog Out High	A066	Advanced	100%	9-17
Analog Out Sel	A065	Advanced	0	9-17
Anlg In 0-10V Hi	A111	Advanced	100.0%	9-32
Anlg In 1-10V Lo	A110	Advanced	0.0%	9-32
Anlg In4-20mA Hi	A113	Advanced	100.0%	9-33
Anlg In4-20mA Lo	A112	Advanced	0.0%	9-33
Anlg Out Setpoint	A109	Advanced	0.0%	9-32
Auto Rstrt Delay	A093	Advanced	1.0 sec	9-27
Auto Rstrt Tries	A092	Advanced	0	9-26
Autotune	A127	Advanced	0 = Ready/Idle	9-37
Boost Select	A084	Advanced	8 = 5.0, CT 7 = 2.5, CT (for 5.0, 7.5, and 10.0 HP drives only)	9-23
Break Frequency	A087	Advanced	15.0 Hz	9-25
Break Voltage	A086	Advanced	25.0%	9-24
Bus Reg Mode	A117	Advanced	1 = Enabled	9-34
Comm Data Rate	A103	Advanced	4 = 19.2 K	9-30
Comm Format	A107	Advanced	0 = RTU 8-N-1	9-31

<b>Parameter Name</b>	<b>No.</b>	<b>Parameter Group</b>	<b>Default Value</b>	<b>Page No.</b>
Comm Loss Action	A105	Advanced	0 = Fault	9-30
Comm Loss Time	A106	Advanced	5.0 sec	9-31
Comm Node Addr	A104	Advanced	1	9-30
Comm Status	d015	Display	Read Only	9-50
Commanded Freq	d002	Display	Read Only	9-46
Compensation	A097	Advanced	1 = Electrical	9-28
Contrl In Status	d013	Display	Read Only	9-49
Control Source	d012	Display	Read Only	9-48
Control SW Ver	d016	Display	Read Only	9-50
Counter Status	d025	Display	Read Only	9-52
Current Limit 1	A089	Advanced	Drive Rated Amps x 1.8	9-25
Current Limit 2	A118	Advanced	Drive Rated Amps x 1.8	9-34
DB Resistor Sel	A082	Advanced	0 = Disabled	9-22
DC Brake Level	A081	Advanced	Drive Rated Amps x 0.5	9-21
DC Brake Time	A080	Advanced	0.0 sec	9-21
DC Bus Voltage	d005	Display	Read Only	9-47
Decel Time 1	P040	Basic	5.0 sec	9-6
Decel Time 2	A068	Advanced	10.0 sec	9-18
Dig In Status	d014	Display	Read Only	9-49
Digital In1 Sel	A051	Advanced	4 = Preset Freq	9-8
Digital In2 Sel	A052	Advanced	4 = Preset Freq	9-8
Digital In3 Sel	A053	Advanced	4 = Preset Freq	9-8
Digital in4 Sel	A054	Advanced	5 = Local	9-8
Drive Status	d006	Display	Read Only	9-47
Drive Temp	d024	Display	Read Only	9-52
Drive Type	d017	Display	Read Only	9-50
Elapsed Run Time	d018	Display	Read Only	9-50
EM Brk Off Delay	A160	Advanced	2.0 sec	9-44
EM Brk On Delay	A161	Advanced	2.0 sec	9-44
Fault 1 Code	d007	Display	Read Only	9-47
Fault 2 Code	d008	Display	Read Only	9-47
Fault 3 Code	d009	Display	Read Only	9-47
Fault Clear	A100	Advanced	0 = Ready/Idle	9-29

<b>Parameter Name</b>	<b>No.</b>	<b>Parameter Group</b>	<b>Default Value</b>	<b>Page No.</b>
Flux Current Ref	A129	Advanced	Based on Drive Rating	9-38
Flying Start En	A096	Advanced	0 = Disabled	9-28
Internal Freq	A069	Advanced	0.0 Hz	9-19
IR Voltage Drop	A128	Advanced	Based on Drive Rating	9-38
Jog Accel/Decel	A079	Advanced	10.0 sec	9-21
Jog Frequency	A078	Advanced	10.0 Hz	9-20
Language	A108	Advanced	1 = English	9-31
Maximum Freq	P035	Basic	60 Hz	9-2
Maximum Voltage	A088	Advanced	Drive Rated Volts	9-25
Minimum Freq	P034	Basic	0.0 Hz	9-2
MOP Reset Sel	A162	Advanced	1 = Save MOP Ref	9-45
Motor NP FLA	A126	Advanced	Drive Rated Amps	9-37
Motor NP Hertz	P032	Basic	60 Hz	9-2
Motor NP Volts	P031	Basic	Varies	9-2
Motor OL Current	P033	Basic	Varies	9-2
Motor OL Select	A090	Advanced	0 = No Derate	9-25
Opto Out Logic	A064	Advanced	0	9-16
Opto Out1 Level	A059	Advanced	0.0	9-16
Opto Out1 Sel	A058	Advanced	0 = Ready/Fault	9-14
Opto Out2 Level	A062	Advanced	0.0	9-16
Opto Out2 Sel	A061	Advanced	2 = Motor Running	9-14
Output Current	d003	Display	Read Only	9-46
Output Freq	d001	Display	Read Only	9-46
Output Power	d022	Display	Read Only	9-51
Output Power Fctr	d023	Display	Read Only	9-51
Output Torque Current	d029	Display	Read Only	9-52
Output Voltage	d004	Display	Read Only	9-46
PID Deadband	A138	Advanced	0.0%	9-40
PID Diff Rate	A136	Advanced	0.0 (1/sec)	9-40
PID Feedback Sel	A133	Advanced	0 = 1-10V Input	9-39
PID Integ Time	A135	Advanced	0.0 sec	9-40

<b>Parameter Name</b>	<b>No.</b>	<b>Parameter Group</b>	<b>Default Value</b>	<b>Page No.</b>
PID Preload	A139	Advanced	0.0 Hz	9-40
PID Prop Gain	A134	Advanced	0.00	9-39
PID Ref Select	A132	Advanced	0 = PID Disabled	9-39
PID Setpoint	A137	Advanced	0.0%	9-40
PID Trim Hi	A130	Advanced	0.0	9-38
PID Trim Lo	A131	Advanced	0.0	9-39
Preset Freq 0	A070	Advanced	0.0 Hz	9-20
Preset Freq 1	A071	Advanced	0.0 Hz	9-20
Preset Freq 2	A072	Advanced	0.0 Hz	9-20
Preset Freq 3	A073	Advanced	0.0 Hz	9-20
Preset Freq 4	A074	Advanced	0.0 Hz	9-20
Preset Freq 5	A075	Advanced	0.0 Hz	9-20
Preset Freq 6	A076	Advanced	0.0 Hz	9-20
Preset Freq 7	A077	Advanced	0.0 Hz	9-20
Process Display	d010	Display	Read Only	9-48
Process Factor	A099	Advanced	30.0	9-29
Process Time Hi	A116	Advanced	0.00	9-34
Process Time Lo	A115	Advanced	0.00	9-33
Program Lock	A101	Advanced	0 = Unlocked	9-29
PWM Frequency	A091	Advanced	4.0 kHz	9-26
Relay Out Level	A056	Advanced	0.0	9-13
Relay Out Sel	A055	Advanced	0 = Ready/Fault	9-11
Reset to Defaults	P041	Basic	0 = Ready/Idle	9-7
Reverse Disable	A095	Advanced	0 = Rev Enabled	9-27
S Curve%	A083	Advanced	0% (Disabled)	9-22
Skip Freq Band	A120	Advanced	0.0 Hz	9-34
Skip Frequency	A119	Advanced	0 Hz	9-34
Slip Hertz @ FLA	A114	Advanced	2.0 Hz	9-33
Speed Reference	P038	Basic	0 = Drive Pot	9-5
Stall Fault Time	A121	Advanced	0 = 60 sec	9-35
Start At PowerUp	A094	Advanced	0 = Disabled	9-27
Start Boost	A085	Advanced	5.0%	9-24
Start Source	P036	Basic	0 = Keypad	9-3
Stop Mode	P037	Basic	1 = Coast, CF	9-4

<b>Parameter Name</b>	<b>No.</b>	<b>Parameter Group</b>	<b>Default Value</b>	<b>Page No.</b>
Stp Logic 0	A140	Advanced	00F1	9-41
Stp Logic 1	A141	Advanced	00F1	9-41
Stp Logic 2	A142	Advanced	00F1	9-41
Stp Logic 3	A143	Advanced	00F1	9-41
Stp Logic 4	A144	Advanced	00F1	9-41
Stp Logic 5	A145	Advanced	00F1	9-41
Stp Logic 6	A146	Advanced	00F1	9-41
Stp Logic 7	A147	Advanced	00F1	9-41
Stp Logic Status	d028	Display	Read Only	9-52
Stp Logic Time 0	A150	Advanced	30.0 sec	9-43
Stp Logic Time 1	A151	Advanced	30.0 sec	9-43
Stp Logic Time 2	A152	Advanced	30.0 sec	9-43
Stp Logic Time 3	A153	Advanced	30.0 sec	9-43
Stp Logic Time 4	A154	Advanced	30.0 sec	9-43
Stp Logic Time 5	A155	Advanced	30.0 sec	9-43
Stp Logic Time 6	A156	Advanced	30.0 sec	9-43
Stp Logic Time 7	A156	Advanced	30.0 sec	9-43
SW Current Trip	A098	Advanced	0.0 (Disabled)	9-28
Testpoint Data	d019	Display	Read Only	9-51
Testpoint Sel	A102	Advanced	400	9-29
Timer Status	d026	Display	Read Only	9-52
Torque Perf Mode	A125	Advanced	1 = Sensrls Vect	9-37
Var PWM Disable	A124	Advanced	0 = Enabled	9-36
Voltage Class	P042	Basic	3 = High Voltage 600V	9-7



# APPENDIX D

---

## CE Conformance Requirements

Conformity with the Low Voltage (LV) Directive and Electromagnetic Compatibility (EMC) Directive has been demonstrated using harmonized European Norm (EN) standards published in the Official Journal of the European Communities. The MD65 AC drive complies with the EN standards listed below when installed according to the User Manual.

CE Declarations of Conformity are available online at:  
<http://www.reliance.com/certification/>.

### **Low Voltage Directive (73/23/EEC)**

- EN50178 Electronic equipment for use in power installations.

### **EMC Directive (89/336/EEC)**

- EN61800-3 (Second Environment) Adjustable speed electrical power drive systems Part 3: EMC product standard including specific test methods.

### **General Notes**

- If the plastic top panel is removed or the optional conduit box is not installed, the drive must be installed in an enclosure with side openings less than 12.5 mm (0.5 in) and top openings less than 1.0 mm (0.04 in) to maintain compliance with the LV Directive.
- The motor cable should be kept as short as possible in order to avoid electromagnetic emission as well as capacitive currents.
- The use of line filters in ungrounded systems is not recommended.
- Conformity of the drive with CE EMC requirements does not guarantee an entire machine installation complies with the CE EMC requirements. Many factors can influence total machine/installation compliance.

## Essential Requirements for CE Compliance

The following conditions **must be** satisfied for MD65 drives to meet the requirements of **EN61800-3**.

- Grounding as described in figure D.1. Refer to chapter 4 for additional grounding recommendations.
- Output power, control (I/O) and signal wiring must be braided, shielded cable with a coverage of 75% or better, metal conduit or equivalent attenuation.
- Allowable cable length in table D.1 is not exceeded.

Table D.1 – Allowable Cable Length

Filter Type	EN61800-3 First Environment Restricted Distribution or Second Environment <sup>2</sup>	EN61800-3 First Environment Unrestricted Distribution <sup>3</sup>
Integral	10 meters (33 feet)	1 meter (3 feet)
External - Short <sup>1</sup>	10 meters (33 feet)	1 meter (3 feet)
External - Long <sup>1</sup>	100 meters (328 feet)	5 meters (16 feet)

<sup>1</sup> Contact Reliance Electric for details on optional external filters.

<sup>2</sup> Equivalent to EN55011 Class A.

<sup>3</sup> Equivalent to EN55011 Class B.

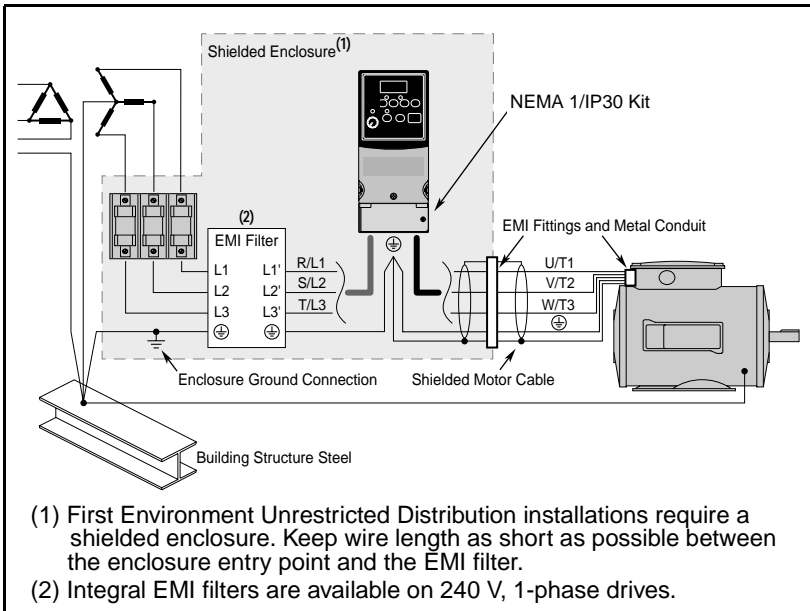

Figure D.1 – Connections and Grounding



### **EN61000-3-2**

- 0.75 kW (1 HP) 240 V 1-phase and 3-phase drives and 0.37 kW (0.5 HP) 240 V 1-phase drives are suitable for installation on a private low-voltage power network. Installations on a public low-voltage power network may require additional harmonic mitigation.
- Other drive ratings meet the current harmonic requirements of EN61000-3-2 without additional external mitigation.



# APPENDIX E

---

## Accessories

Appendix E contains information on accessories available with the MD65 AC Drive. This appendix has information on:

- Dynamic Brake Modules
- EMC Line Filters
- Operator Interface Modules (OIMs)

# E.1 Dynamic Brake Modules

Table E.1 – Dynamic Brake Modules

Drive Ratings				Min. Resistance	Model Number <sup>1</sup>
Input Voltage	kW	HP			
120V 50/60 Hz 1-Phase	0.4	0.5		48	AK-R2-091P500
	0.75	1.0		48	AK-R2-091P500
	1.1	1.5		48	AK-R2-091P500
240V 50/60 Hz 1-Phase	0.4	0.5		48	AK-R2-091P500
	0.75	1.0		48	AK-R2-091P500
	1.5	2.0		48	AK-R2-091P500
	2.2	3.0		32	AK-R2-047P500
240V 50/60 Hz 3-Phase	0.4	0.5		48	AK-R2-091P500
	0.75	1.0		48	AK-R2-091P500
	1.5	2.0		48	AK-R2-091P500
	2.2	3.0		32	AK-R2-047P500
	3.7	5.0		19	AK-R2-047P500
	5.5	7.5		13	AK-R2-030P1K2
	7.5	10.0		10	AK-R2-030P1K2
480V 50/60 Hz 3-Phase	0.4	0.5		97	AK-R2-360P500
	0.75	1.0		97	AK-R2-360P500
	1.5	2.0		97	AK-R2-360P500
	2.2	3.0		97	AK-R2-120P1K2
	4.0	5.0		77	AK-R2-120P1K2
	5.5	7.5		55	AK-R2-120P1K2
	7.5	10.0		39	AK-R2-120P1K2
	11.0	15.0		24	AK-R2-120P1K2 <sup>2</sup>
600V 50/60 Hz 3-Phase	0.75	1.0		120	AK-R2-360P500
	1.5	2.0		120	AK-R2-360P500
	2.2	3.0		82	AK-R2-120P1K2
	4.0	5.0		82	AK-R2-120P1K2
	5.5	7.5		51	AK-R2-120P1K2
	7.5	10.0		51	AK-R2-120P1K2
	11.0	15.0		51	AK-R2-120P1K2 <sup>2</sup>

<sup>1</sup> The resistors listed in this table are rated for 5% duty cycle.

<sup>2</sup> Requires two resistors wired in parallel.

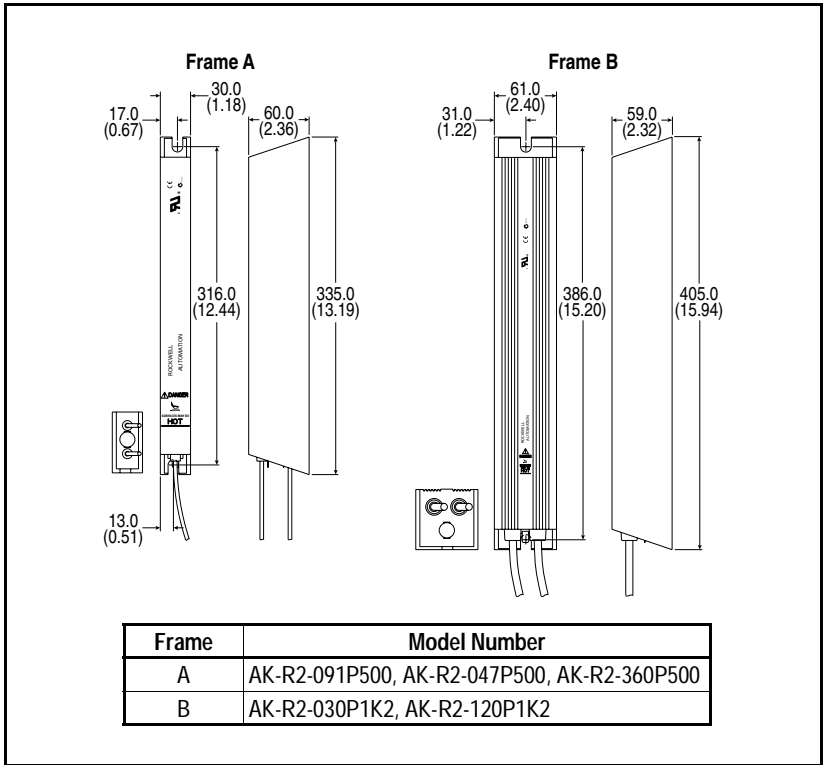

Figure E.1 – Dynamic Brake Modules: Dimensions

## E.2 EMC Line Filters

Table E.2 – EMC Line Filters

Drive Ratings			S Type Filter Model Number <sup>1</sup>	L Type Filter Model Number <sup>4</sup>
Input Voltage	kW	HP		
120V 50/60 Hz 1-Phase	0.4	0.5	–	6MDF-018BL
	0.75	1.0	–	6MDF-018BL
	1.1	1.5	–	6MDF-018BL
240V 50/60 Hz 1-Phase	0.4	0.5	<sup>2</sup>	6MDF-018BL
	0.75	1.0	<sup>2</sup>	6MDF-018BL
	1.5	2.0	<sup>2</sup>	6MDF-018BL
	2.2	3.0	<sup>2</sup>	6MDF-025CL
240V 50/60 Hz 3-Phase	0.4	0.5	6MDF-021BS <sup>3</sup>	6MDF-021BL
	0.75	1.0	6MDF-021BS <sup>3</sup>	6MDF-021BL
	1.5	2.0	6MDF-021BS <sup>3</sup>	6MDF-021BL
	2.2	3.0	6MDF-021BS <sup>3</sup>	6MDF-021BL
	3.7	5.0	6MDF-021BS <sup>3</sup>	6MDF-021BL
	5.5	7.5	6MDF-034CS	6MDF-034CL
480V 50/60 Hz 3-Phase	0.4	0.5	6MDF-012BS	6MDF-012BL
	0.75	1.0	6MDF-012BS	6MDF-012BL
	1.5	2.0	6MDF-012BS	6MDF-012BL
	2.2	3.0	6MDF-012BS	6MDF-012BL
	4.0	5.0	6MDF-012BS	6MDF-012BL
	5.5	7.5	6MDF-018CS	6MDF-018CL
	7.5	10.0	6MDF-018CS	6MDF-018CL
	11.0	15.0	6MDF-026CS	6MDF-026CL
600V 50/60 Hz 3-Phase	0.75	1.0	–	6MDF-008BL
	1.5	2.0	–	6MDF-008BL
	2.2	3.0	–	6MDF-008BL
	4.0	5.0	–	6MDF-008BL
	5.5	7.5	–	6MDF-015BL
	7.5	10.0	–	6MDF-015BL
	11.0	15.0	–	6MDF-022BL

<sup>1</sup> This filter is suitable for use with a cable length of at least 10 meters (33 feet) for Class A and 1 meter for Class B environments.

<sup>2</sup> These ratings can be ordered with internal “S Type” filters.

<sup>3</sup> Filter must be Series B or later.

<sup>4</sup> This filter is suitable for use with a cable length of at least 100 meters for Class A and 5 meters for Class B environments.

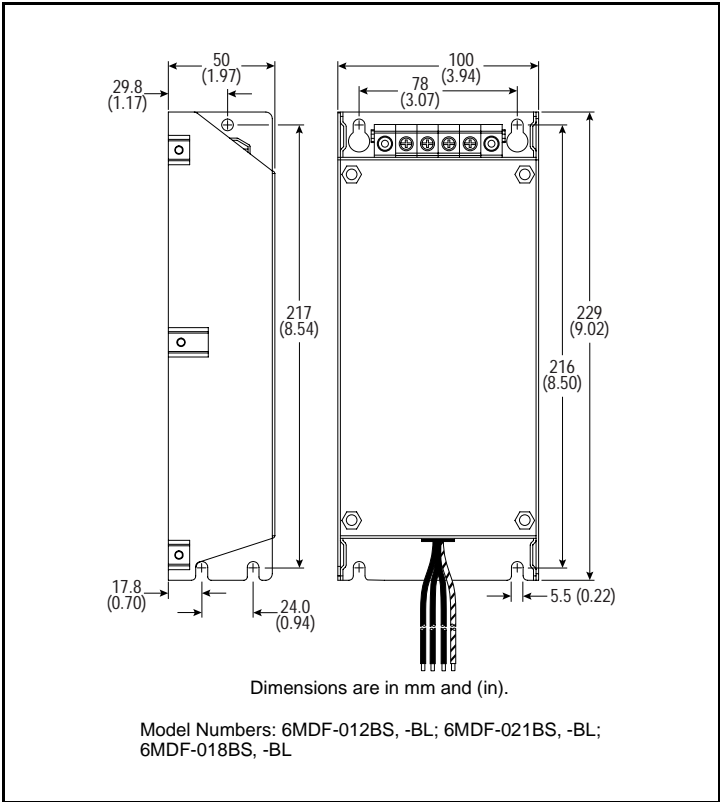
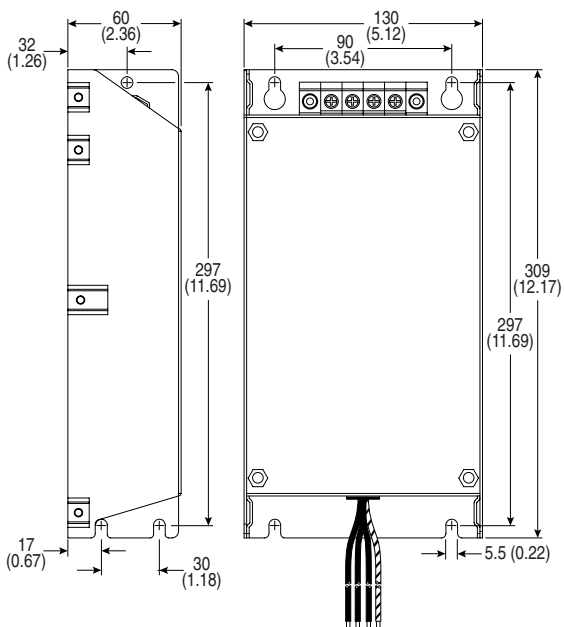

Figure E.2 – Frame B EMC Line Filters: Dimensions



Dimensions are in mm and (in).

Model Numbers: 6MDF-018CS, -CL; 6MDF-034CS, -CL;  
6MDF-025CL

Figure E.3 – Frame C EMC Line Filters: Dimensions



## E.3 Operator Interface Modules (OIMs)

Table E.3 – Operator Interface Modules/Accessories

Description	Model Number
Remote Panel-Mount OIM (digital speed control, CopyCat capable, IP66 (NEMA 4x12) indoor use only, includes 2.9 meter cable)	MD4LCD-PNL
Remote Handheld OIM (digital speed control, full numeric keypad, CopyCat capable, IP30 (NEMA Type 1); includes 1.0 meter cable; panel-mount with optional Bezel Kit)	MD1CC
Bezel Kit (panel mount for Remote Handheld OIM)	MDBZL-N1
OIM Cable (1.0 meter OIM-to-RJ45 cable)	MDCBL-CC1
OIM Cable (2.9 meter OIM-to-RJ45 cable)	MDCBL-CC3

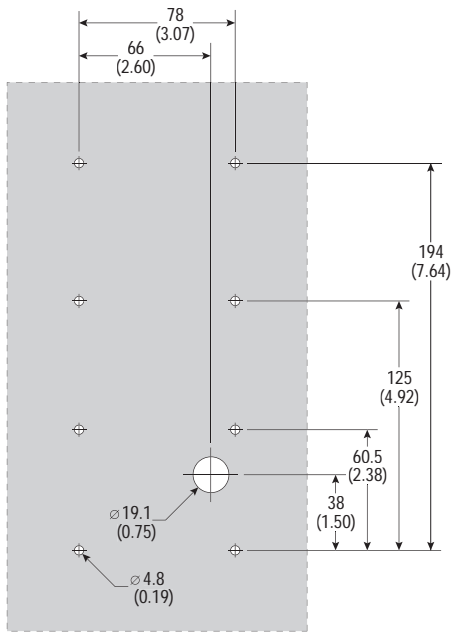
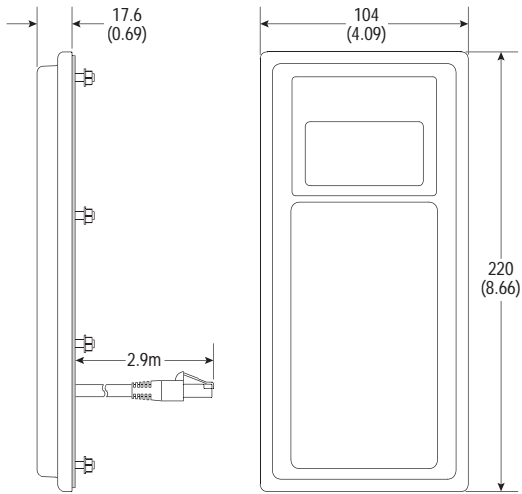

Dimensions are in mm and (in).

Figure E.4 – Remote OIM (M/N MD4LCD-PNL)

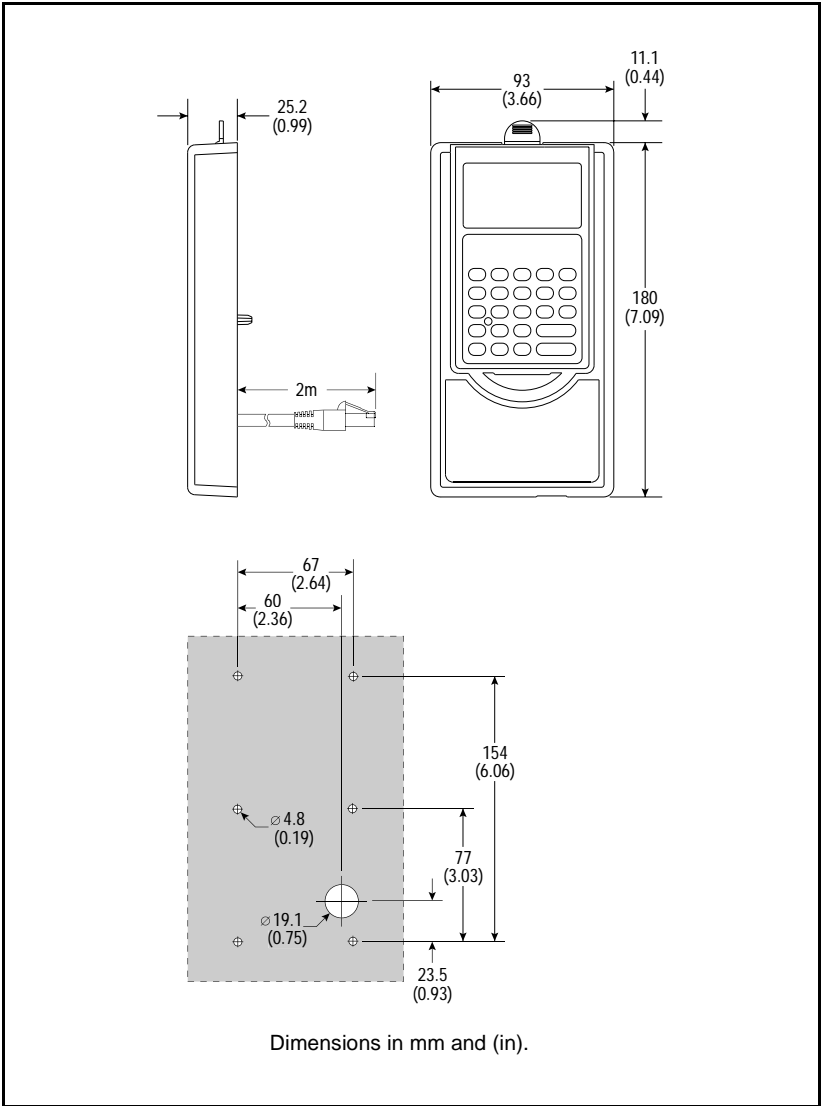

Figure E.5 – NEMA Type 1 Bezel (M/N MDBZL-N1): Dimensions



# APPENDIX F

## RS485 (MDI) Protocol

MD65 drives support the RS485 (MDI) protocol to allow efficient operation with Rockwell Automation peripherals. In addition, some Modbus functions are supported to allow simple networking. MD65 drives can be multi-dropped on an RS485 network using Modbus protocol in RTU mode.

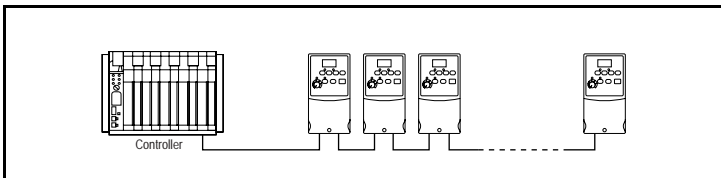

Figure F.1 – Sample Network

For information regarding DeviceNet or other communication protocols, refer to the appropriate user manual.

### Network Wiring

Network wiring consists of a shielded 2-conductor cable that is daisy-chained from node to node. See figure F.2.

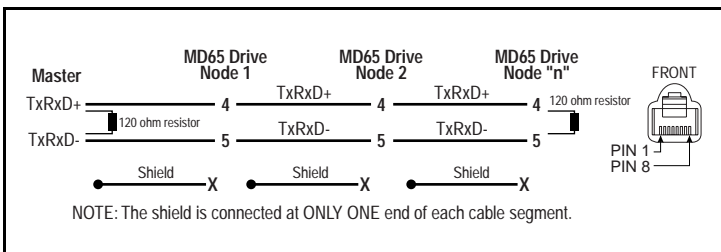

Figure F.2 – Network Wiring Diagram

Only pins 4 and 5 on the RJ45 plug should be wired. The other pins on the MD65 RJ45 socket contain power, etc., for other Rockwell Automation peripheral devices and must not be connected.

Wiring terminations on the master controller will vary depending on the master controller used and “TxRxD+” and “TxRxD-” are shown for illustration purposes only. Refer to the master controller’s user manual for network terminations. Note that there is no standard for the “+” and “-” wires, and consequently Modbus device manufacturers interpret them differently. If you have problems with initially establishing communications, try swapping the two network wires at the master controller.

Standard RS485 wiring practices apply. Termination resistors need to be applied at each end of the network cable. RS485 repeaters may need to be used for long cable runs, or if greater than 32 nodes are needed on the network.

Control Terminal 19 on the MD65 must also be connected to PE ground (there are two PE terminals on the drive).

## Parameter Configuration

The following MD65 parameters are used to configure the drive to operate on a network.

Table F.1 – MD65 Network Parameters

Parameter	Details
P036 (Start Source)	Set to 5 “RS485 (MDI) Port” if Start is controlled from the network.
P038 (Speed Reference)	Set to 5 “RS485 (MDI) Port” if the Speed Reference is controlled from the network.
A103 (Comm Data Rate)	Sets the data rate for the RS485 (MDI) Port. All nodes on the network must be set to the same data rate.
A104 (Comm Node Addr)	Sets the node address for the drive on the network. Each device on the network requires a unique node address.
A105 (Comm Loss Action)	Selects the drive’s response to communication problems.
A106 (Comm Loss Time)	Sets the time that the drive will remain in communication loss before the drive implements A105 (Comm Loss Action).
A107 (Comm Format)	Sets the transmission mode, data bits, parity and stop bits for the RS485 (MDI) Port. All nodes on the network must be set to the same setting.

## Supported Modbus Function Codes

The peripheral interface (MDI) used on MD65 drives supports some of the Modbus function codes.

Table F.2 – Supported Modbus Function Codes

Modbus Function Code	Command
03	Read Holding Registers
06	Preset (Write) Single Register

**Important:** Modbus devices can be 0-based (registers are numbered starting at 0) or 1-based (registers are numbered starting at 1). Depending on the Modbus Master used, the register addresses listed on the following pages may need to be offset by +1. For example, Logic Command may be register address 8192 for some master devices (e.g., ProSoft 3150-MCM SLC Modbus scanner) and 8193 for others (e.g., PanelViews).

## Writing (06) Logic Command Data

The MD65 drive can be controlled via the network by sending Function Code 06 writes to register address 8192 (Logic Command). P036 (Start Source) must be set to 5 “RS485 (MDI Port)” in order to accept the commands.

Table F.3 – Logic Commands

Logic Command		
Address (Decimal)	Bit(s)	Description
8192	0	1 = Stop, 0 = Not Stop
	1	1 = Start, 0 = Not Start
	2	1 = Jog, 0 = No Jog
	3	1 = Clear Faults, 0 = Not Clear Faults
	5,4	00 = No Command 01 = Forward Command 10 = Reverse Command 11 = Change Direction (Toggle)
	6	Not Used
	7	Not Used
	9,8	00 = No Command 01 = Accel Rate 1 Enable 10 = Accel Rate 2 Enable 11 = Hold Accel Rate Selected
	11,10	00 = No Command 01 = Decel Rate 1 Enable 10 = Decel Rate 2 Enable 11 = Hold Decel Rate Selected
	14,13,12	000 = No Command 001 = Freq. Source = P036 (Start Source) 010 = Freq. Source = A069 (Internal Freq) 011 = Freq. Source = Comms (Addr 8193) 100 = A070 (Preset Freq 0) 101 = A071 (Preset Freq 1) 110 = A072 (Preset Freq 2) 111 = A073 (Preset Freq 3)
15	Not Used	



## Writing (06) Reference

The Speed Reference to a MD65 drive can be controlled via the network by sending Function Code 06 writes to register address 8193 (Reference). P038 (Speed Reference) must be set to 5 "RS485 (MDI) Port" in order to accept the Speed Reference.

Table F.4 – Reference

Reference	
Address (Decimal)	Description
8193	A decimal value entered as xxx.x where the decimal point is fixed. For example, a decimal "100" equals 10.0 Hz and "543" equals 54.3 Hz.

## Reading (03) Logic Status Data

The MD65 Logic Status data can be read via the network by sending Function Code 03 reads to register address 8448 (Logic Status).

Table F.5 – Logic Status Data

Logic Status		
Address (Decimal)	Bit(s)	Description
8448	0	1 = Ready, 0 = Not Ready
	1	1 = Active (Running), 0 = Not Active
	2	1 = Cmd Forward, 0 = Cmd Reverse
	3	1 = Rotating Forward, 0 = Rotating Reverse
	4	1 = Accelerating, 0 = Not Accelerating
	5	1 = Decelerating, 0 = Not Decelerating
	6	1 = Alarm, 0 = No Alarm
	7	1 = Faulted, 0 = Not Faulted
	8	1 = At Reference, 0 = Not At Reference
	9	1 = Reference Controlled by Comm
	10	1 = Operation Cmd Controlled by Comm
	11	1 = Parameters have been locked
	12	Digital Input 1 Status
	13	Digital Input 2 Status
	14	Not Used
15	Not Used	

## Reading (03) Feedback

The Feedback (Output Frequency) from the MD65 drive can be read via the network by sending Function Code 03 reads to register address 8451 (Feedback).

Table F.6 – Feedback

Feedback <sup>1</sup>	
Address (Decimal)	Description
8451	A xxx.x decimal value where the decimal point is fixed. For example, a decimal "123" equals 12.3 Hz and "300" equals 30.0 Hz.

<sup>1</sup> Returns the same data as Reading (03) Parameter d001 (Output Freq).

## Reading (03) Drive Error Codes

The MD65 Error Code data can be read via the network by sending Function Code 03 reads to register address 8449 (Drive Error Codes).

Table F.7 – Error Codes

Logic Status		
Address (Decimal)	Value (Decimal)	Description
8449	0	No Fault
	2	Auxiliary Input
	3	Power Loss
	4	Undervoltage
	5	Overvoltage
	6	Motor Stalled
	7	Motor Overload
	8	Heatsink Overtemperature
	12	HW Overcurrent (300%)
	13	Ground Fault
	29	Analog Input Loss
	33	Auto Restart Tries
	38	Phase U to Ground Short
	39	Phase V to Ground Short
	40	Phase W to Ground Short
	41	Phase UV Short
	42	Phase UW Short
	43	Phase VW Short
	63	Software Overcurrent
	64	Drive Overload
70	Power Unit Fail	
80	AutoTune Fail	
81	Communication Loss	
100	Parameter Checksum Error	
122	I/O Board Fail	

## **Reading (03) and Writing (06) Drive Parameters**

To access drive parameters, the Modbus register address equals the parameter number. For example, a decimal "1" is used to address parameter d001 (Output Freq) and decimal "39" is used to address parameter P039 (Accel Time 1).

## RJ45 Splitter Cable

The MD65 drive provides a RJ45 port to allow the connection of a single peripheral device. The RJ45 Splitter Cable can be used to connect a second MDI peripheral device to the drive.

### Connectivity Guidelines



**ATTENTION:** The peripherals may not perform as intended if these Connectivity Guidelines are not followed. Precautions should be taken to follow these Connectivity Guidelines. Failure to observe these precaution may result in damage to, or destruction of, the equipment.

- Two peripherals maximum can be attached to a drive.
- If a single peripheral is used, it must be connected to the Master port (M) on the splitter and configured for “Auto” (default) or “Master.” Parameter 9 (Device Type) on the OIM keypads and parameter 1 (Module Cfg) on the Serial Converter are used to select the type (Auto / Master / Slave).
- **Do not use the RJ45 Splitter Cable with a drive that has an internal network communication module installed.** Since only one additional peripheral can be added, the second peripheral can be connected directly to the RJ45 port on the drive. The internal Comm is always the Master, therefore the external peripheral must be configured as “Auto” (for temporary connections) or “Slave” (for permanent connections).
- If two peripherals will be powered up at the same time, one must be configured as the “Master” and connected to the Master port (M) and the other must be connected as the “Slave” and connected to the Slave port (S).

## Cable Accessories

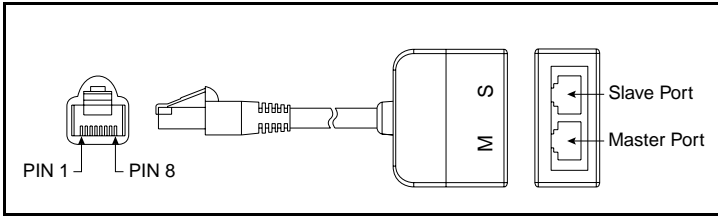

Figure G.1 – RJ45 Splitter Cable (M/N AK-U0-RJ45-SCI)

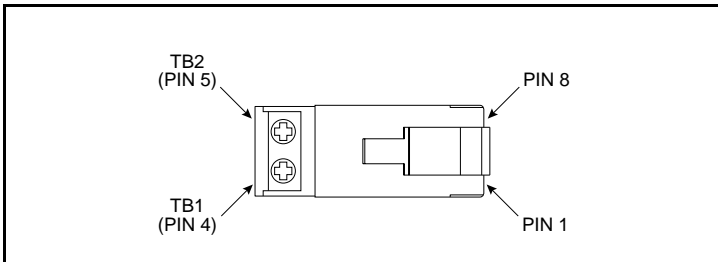

Figure G.2 – RJ45 Two-Position Terminal Block Module  
M/N AK-U0-RJ45-TB2P

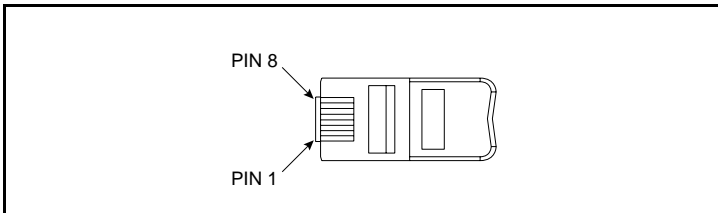

Figure G.3 – RJ45 Module With Integrated Termination Resistor  
(M/N AK-U0-RJ45-TR1)

## Connecting One Temporary Peripheral

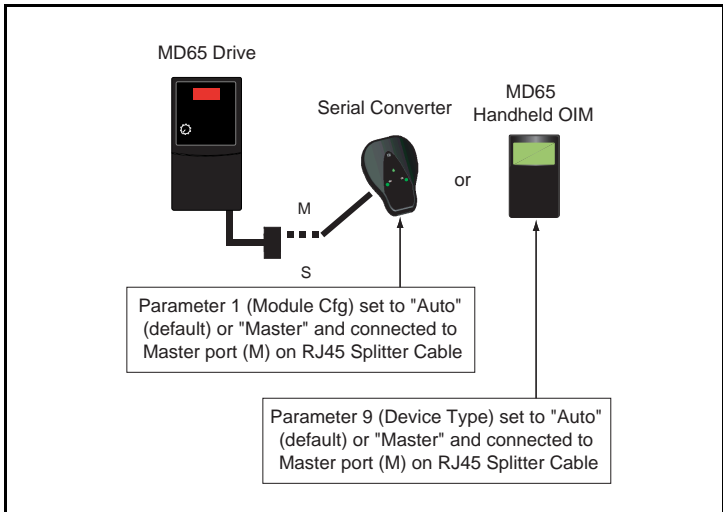

Figure G.4 – Connecting One Temporary Peripheral

## Connecting One Temporary Peripheral and One Permanent Peripheral

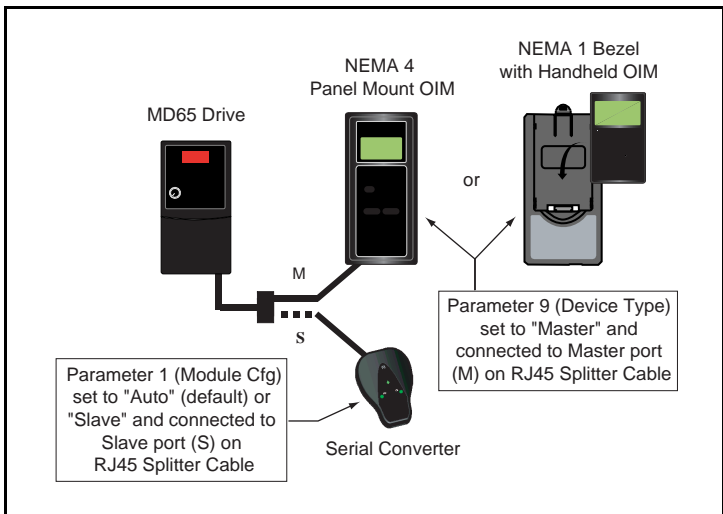

Figure G.5 – Connecting One Temporary Peripheral and One Permanent Peripheral

## Connecting Two Permanent Peripherals

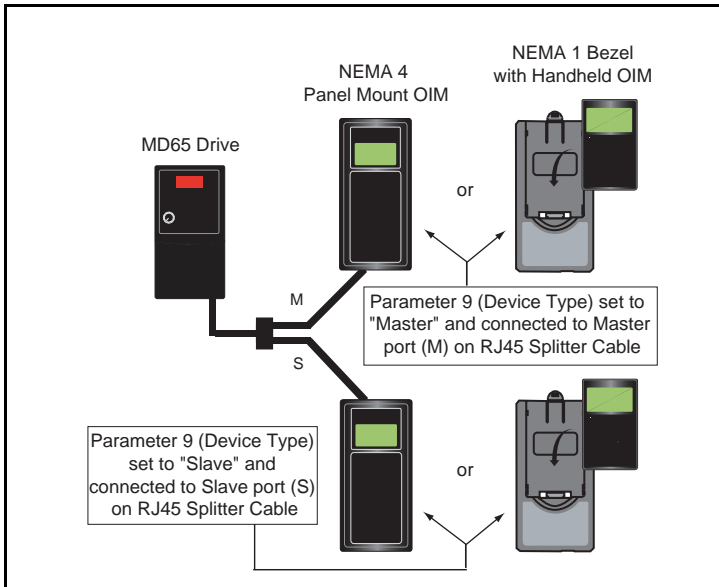

Figure G.6 – Connecting Two Permanent Peripherals

## Connecting an RS485 Network

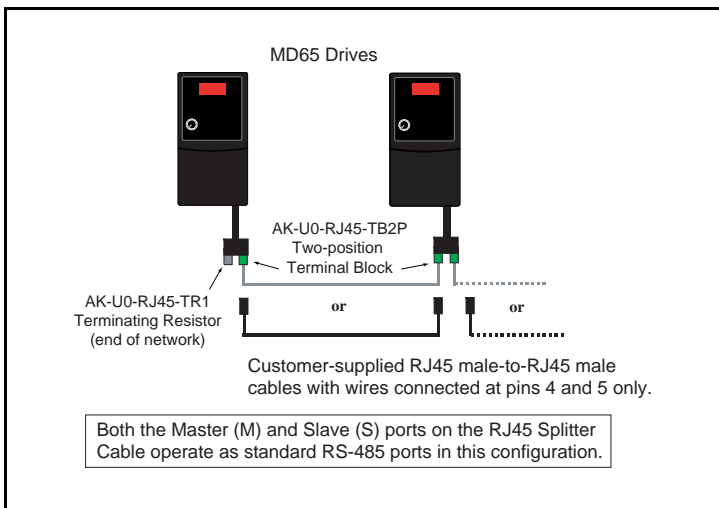

Figure G.7 – Connecting an RS485 Network



## StepLogic™, Basic Logic and Timer/Counter Functions

Four MD65 drive logic functions provide the capability to program simple logic functions without a separate controller.

- StepLogic™ Function

Steps through up to eight preset speeds based on programmed logic. Programmed logic can include conditions that need to be met from digital inputs programmed as “Logic In1” and “Logic In2” before stepping from one preset speed to the next. A timer is available for each of the eight steps and is used to program a time delay before stepping from one preset speed to the next. The status of a digital output can also be controlled based on the step being executed.

- Basic Logic Function

Up to two digital inputs can be programmed as “Logic In1” and/or “Logic In2”. A digital output can be programmed to change state based on the condition of one or both inputs based on basic logic functions such as AND, OR, NOR. The basic logic functions can be used with or without StepLogic™.

- Timer Function

A digital input can be programmed for “Timer Start”. A digital output can be programmed as a “Timer Out” with an output level programmed to the desired time. When the timer reaches the time programmed into the output level the output will change state. The timer can be reset via a digital input programmed as “Reset Timer”.

- Counter Function

A digital input can be programmed for “Counter In”. A digital output can be programmed as “Counter Out” with an output

level programmed to the desired number of counts. When the counter reaches the count programmed into the output level the output will change state. The counter can be reset via a digital input programmed as “Reset Counter”.

## StepLogic™ Using Timed Steps

To activate this function, set Speed Reference (P038) to 6 “Stp Logic”. Three parameters are used to configure the logic, speed reference and time for each step.

- Logic is defined using Stp Logic x parameters (A140-A147).
- Preset Speeds are set with Preset Freq x parameters (A070-A077).
- Time of operation for each step is set with Stp Logic Time x parameters (A150-A157).

The direction of motor rotation can be forward or reverse.

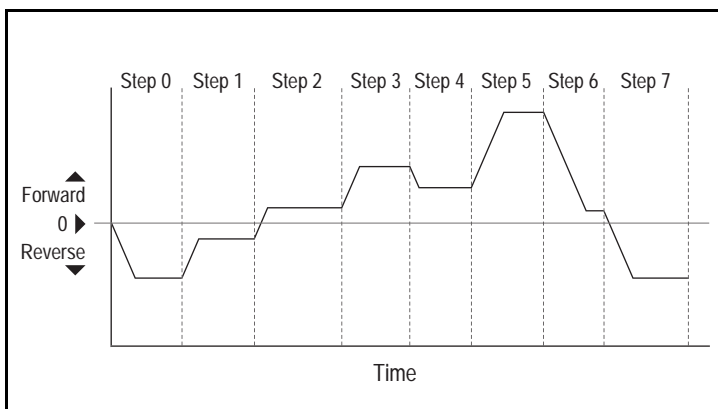

Figure H.1 – Using Timed Steps

## StepLogic™ Sequence

- Sequence begins with a valid start command.
- A normal sequence begins with Step 0 and transition to the next step when the corresponding StepLogic™ time has expired.
- Step 7 is followed by Step 0
- Sequence repeats until a stop is issued or a fault condition occurs.

## StepLogic™ Using Basic Logic Functions

Digital input and digital output parameters can be configured to use logic to transition to the next step. Logic In1 and Logic In2 are defined by programming Digital Inx Sel parameters (A051-A054) to option 23 “Logic In1” or option 24 “Logic In2”.

### Example

- Run at Step 0.
- Transition to Step 1 when Logic In1 is true. Logic senses the edge of Logic In1 when it transitions from off to on. Logic In1 is not required to remain “on”.
- Transition to Step 2 when both Logic In1 and Logic In2 are true. The drive senses the level of both Logic In1 and Logic In2 and transitions to Step 2 when both are on.
- Transition to Step 3 when Logic In2 returns to a false or off state. Inputs are not required to remain in the “on” condition except under the logic conditions used for the transition from Step 2 to Step 3.

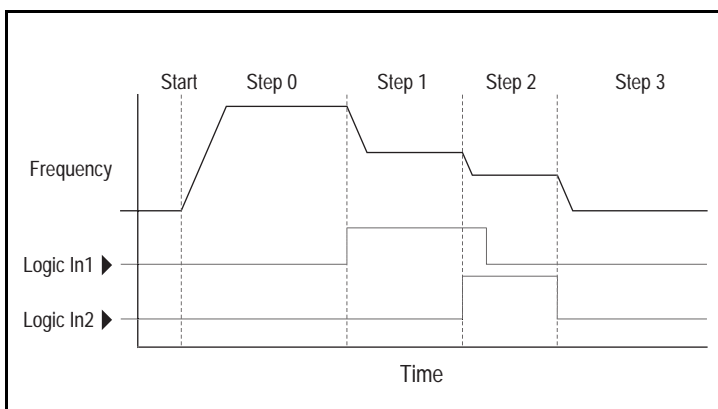

The step time value and the basic logic may be used together to satisfy machine conditions. For instance, the step may need to run for a minimum time period and then use the basic logic to trigger a transition to the next step.

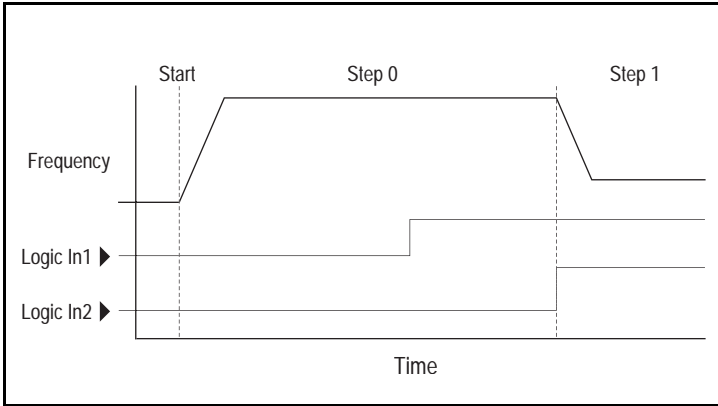

## Timer Function

Digital inputs and outputs control the timer function and are configured with Digital Inx Sel parameters (A051-A054) set to 18 "Timer Start" and 20 "Reset Timer".

Digital outputs (relay and type) define a preset level and indicate when the level is reached. Level parameters Relay Out Level (A056), Opto Out1 Level (A059) and Opto Out2 Level (A062) are used to set the desired time in seconds.

Parameters Relay Out Sel (A055), Opto Out1 Sel (A058) and Opto Out2 Sel (A061) are set to option 16 "Timer Out" and causes the output to change state when the preset level is reached.

### Example

- Drive starts up and accelerates to 30 Hz.
- After 30Hz has been maintained for 20 seconds, a 4-20mA analog input becomes the reference signal for speed control.
- The timer function is used to select a preset speed with a 20 second run time that overrides the speed reference while the digital input is active.
- Parameters are set to the following options:
- Speed Reference (P038) = 3 "4-20mA Input"

- Digital In1 Sel (A051) = 4 “Preset Freq”
  - Digital In2 Sel (A052) = 18 “Timer Start”
  - Relay Out Sel (A055) = 16 “Timer Out”
  - Relay Out Level (A056) = 20.0 Sec
  - Preset Freq 1 (A071) = 30.0 Hz
- The control terminal block is wired such that a start command will also trigger the timer start.
- The relay output is wired to I/O Terminal 05 (Digital Input 1) so that it forces the input on when the timer starts.
- After the timer is complete, the output is turned off releasing the preset speed command. The drive defaults to following the analog input reference as programmed.

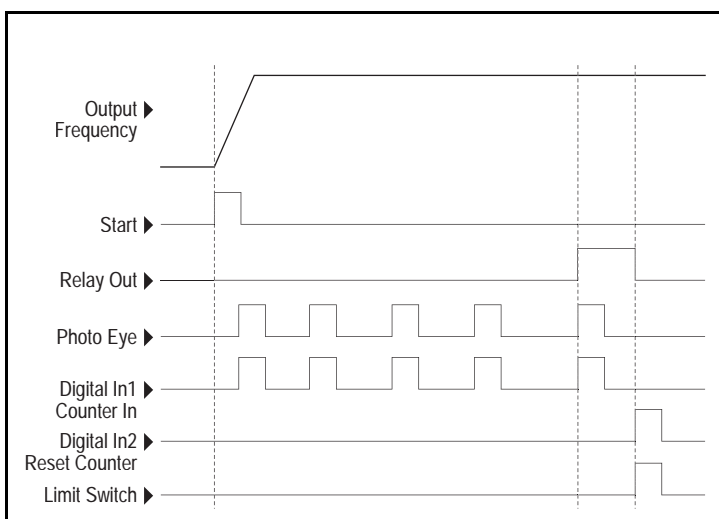

Note that a “Reset Timer” input is not required for this example since the “Timer Start” input both clears and starts the timer.

## Counter Function

Digital inputs and outputs control the counter function and are configured with Digital Inx Sel parameters (A051-A054) set to 19 “Counter In” and 21 “Reset Counter”.

Digital outputs (relay and opto type) define a preset level and indicate when the level is reached. Level parameters Relay Out Level (A056), Opto Out1 Level (A059) and Opto Out2 Level (A062) are used to set the desired count value.

Parameters Relay Out Sel (A055), Opto Out1 Sel (A058) and Opto Out2 Sel (A06)1 are set to 17 “Counter Out” which causes the output to change state when the level is reached.

### Example

- A photo eye is used to count packages on a conveyor line.
- An accumulator holds the packages until 5 are collected.
- A diverter arm redirects the group of 5 packages to a bundling area.
- The diverter arm returns to its original position and triggers a limit switch that resets the counter.
- Parameters are set to the following options:
  - Digital In1 Sel (A051) set to 19 to select “Counter In”
  - Digital In2 Sel (A052) set to 21 to select “Reset Counter”
  - Relay Out Sel (A055) set to 17 to select “Counter Out”
  - Relay Out Level (A056) set to 5.0 (counts)

## StepLogic™ Parameters

Table H.1 – Digit 3 – Defines the action during the step currently executing.

Digit 3	Digit 2	Digit 1	Digit 0
0	0	F	1

Table H.2 – Digit 3 – Defines the action during the step currently executing.

Setting	Accel/Decel Parameters Used	StepLogic™ Output State	Commanded Direction
0	1	Off	FWD
1	1	Off	REV
2	1	Off	No Output
3	1	On	FWD
4	1	On	REV
5	1	On	No Output
6	2	Off	FWD
7	2	Off	REV
8	2	Off	No Output
9	2	On	FWD
A	2	On	REV
b	2	On	No Output

Table H.3 – Digit 2 – Defines what step to jump to or how to end program when the logic conditions specified in Digit 1 are met.

Setting	Logic
0	Jump to Step 0
1	Jump to Step 1
2	Jump to Step 2
3	Jump to Step 3
4	Jump to Step 4
5	Jump to Step 5
6	Jump to Step 6
7	Jump to Step 7
8	End Program (Normal Stop)
9	End Program (Coast to Stop)
A	End Program and Fault (F2)

Table H.4 – Digit 1 – Defines what logic must be met to jump to a step other than the very next step.

Setting	Description	Logic
0	Skip Step (jump immediately)	SKIP
1	Step based on the time programmed in the respective [Stp Logic Time x] parameter.	TIMED
2	Step if "Logic In1" is active (logically true)	TRUE
3	Step if "Logic In2" is active (logically true)	TRUE
4	Step if "Logic In1" is not active (logically false)	FALSE
5	Step if "Logic In2" is not active (logically false)	FALSE
6	Step if either "Logic In1" or "Logic In2" is active (logically true)	OR
7	Step if both "Logic In1" and "Logic In2" is active (logically true)	AND
8	Step if neither "Logic In1" or "Logic In2" is active (logically true)	NOR
9	Step if "Logic In1" is active (logically true) and "Logic In2" is not active (logically false)	XOR
A	Step if "Logic In2" is active (logically true) and "Logic In1" is not active (logically false)	XOR
b	Step after [Stp Logic Time x] and "Logic In1" is active (logically true)	TIMED AND
C	Step after [Stp Logic Time x] and "Logic In2" is active (logically true)	TIMED AND
d	Step after [Stp Logic Time x] and "Logic In1" is not active (logically false)	TIMED OR
E	Step after [Stp Logic Time x] and "Logic In2" is not active (logically false)	TIMED OR
F	Do not step OR no "jump to", so use Digit 0 logic	IGNORE

Table H.5 – Digit 0 – Defines what logic must be met to jump to the very next step.

Setting	Description	Logic
0	Skip Step (jump immediately)	SKIP
1	Step based on the time programmed in the respective [Stp Logic Time x] parameter.	TIMED
2	Step if "Logic In1" is active (logically true)	TRUE
3	Step if "Logic In2" is active (logically true)	TRUE
4	Step if "Logic In1" is not active (logically false)	FALSE
5	Step if "Logic In2" is not active (logically false)	FALSE
6	Step if either "Logic In1" or "Logic In2" is active (logically true)	OR
7	Step if both "Logic In1" and "Logic In2" is active (logically true)	AND
8	Step if neither "Logic In1" or "Logic In2" is active (logically true)	NOR
9	Step if "Logic In1" is active (logically true) and "Logic In2" is not active (logically false)	XOR
A	Step if "Logic In2" is active (logically true) and "Logic In1" is not active (logically false)	XOR
b	Step after [Stp Logic Time x] and "Logic In1" is active (logically true)	TIMED AND
C	Step after [Stp Logic Time x] and "Logic In2" is active (logically true)	TIMED AND
d	Step after [Stp Logic Time x] and "Logic In1" is not active (logically false)	TIMED OR
E	Step after [Stp Logic Time x] and "Logic In2" is not active (logically false)	TIMED OR
F	Use logic programmed in Digit 1	IGNORE



## PID Set Up

### PID Loop

The MD65 has a built-in PID (proportional, integral, differential) control loop. The PID loop is used to maintain a process feedback (such as pressure, flow or tension) at a desired set point. The PID loop works by subtracting the PID feedback from a reference and generating an error value. The PID loop reacts to the error, based on the PID Gains, and outputs a frequency to try to reduce the error value to 0. To enable the PID loop, PID Ref Sel (A132) must be set to an option other than 0 "PID Disabled".

### Exclusive Control

In Exclusive Control, the Speed Reference becomes 0, and the PID Output becomes the entire Freq Command. Exclusive Control is used when PID Ref Sel (A132) is set to option 1, 2, 3 or 4. This configuration does not require a master reference, only a desired set point, such as a flow rate for a pump.

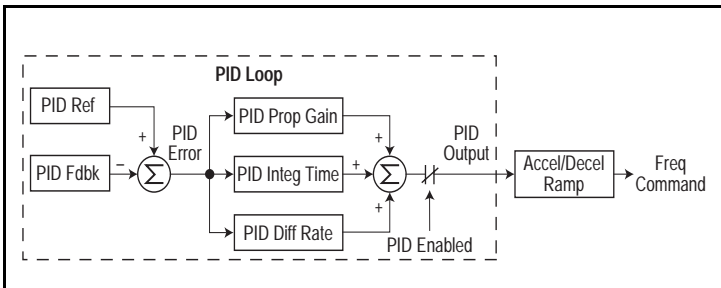

### Example

- In a pumping application, the PID Reference equals the Desired System Pressure set point.
- The Pressure Transducer signal provides PID Feedback to the drive. Fluctuations in actual system pressure, due to changes in flow, result in a PID Error value.
- The drive output frequency increases or decreases to vary motor shaft speed to correct for the PID Error value.
- The Desired System Pressure set point is maintained as values in the system are opened and closed causing changes in flow.

- When the PID Control Loop is disabled, the Commanded Speed is the Ramped Speed Reference.

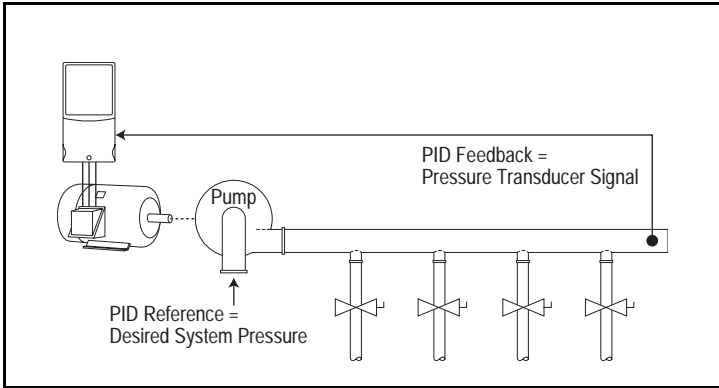

### Trim Control

In Trim Control, the PID Output is added to the Speed Reference. In Trim mode, the output of the PID loop bypasses the accel/decel ramp as shown. Trim Control is used when PID Ref Sel (A132) is set to option 5, 6, 7 or 8.

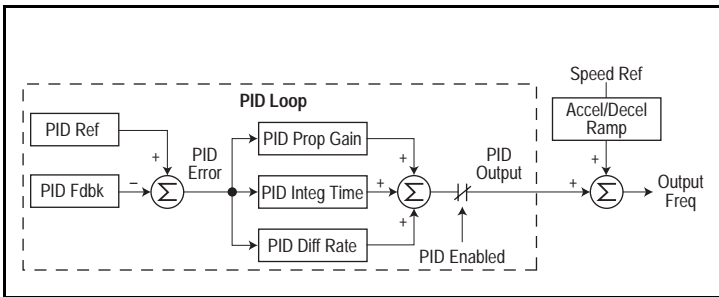

### Example

- In a winder application, the PID Reference equals the Equilibrium set point.
- The Dancer Pot signal provides PID Feedback to the drive. Fluctuations in tension result in a PID Error value.
- The Master Speed Reference sets the wind/unwind speed.

- As tension increases or decreases during winding, the Speed Reference is trimmed to compensate. Tension is maintained near the Equilibrium set point.

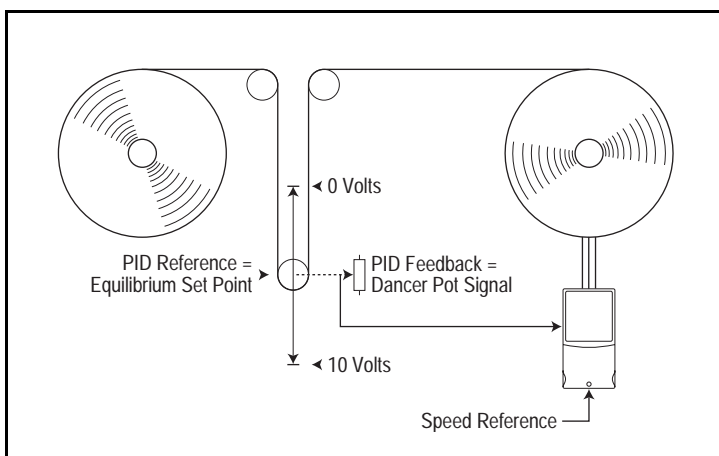

## PID Reference and Feedback

PID Ref Sel (A132) is used to enable the PID mode (A132 does not equal 0; "PID Disabled") and to select the source of the PID Reference. If PID Ref Sel (A132) is not set to 0 "PID Disabled", PID can still be disabled by select programmable digital input options (parameters A051-A054) such as "Jog", "Local" or "PID Disable".

Table I.1 – PID Ref Sel (A132) Options

Option	Description
0 "PID Disabled"	Disables the PID loop (default setting)
1 "PID Setpoint"	Selects Exclusive Control. A137 [PID Setpoint] will be used to set the value of the PID Reference
2 "0-10V Input"	Selects Exclusive Control. Selects the 0-10V Input. Note that the PID will not function with a bipolar analog input. It will ignore any negative voltages and treat them like a zero.
3 "4-20mA Input"	Selects Exclusive Control. Selects the 4-20mA Input.
4 "Comm Port"	Selects Exclusive Control. The reference word from a communication network such as Modbus RTU or DeviceNet becomes the PID Reference. The value sent over the network is scaled so that P035 [Maximum Freq] x 10 = 100% reference. For example, with [Maximum Freq] = 60 Hz, a value of 600 sent over the network would represent 100% reference.
5 "Setpnt, Trim"	Selects Trim Control. A137 [PID Setpoint] will be used to set the value of the PID Reference.
6 "0-10V, Trim"	Selects Trim Control. Selects the 0-10V Input. Note that the PID will not function with a bipolar analog input. It will ignore any negative voltages and treat them like a zero.
7 "4-20mA, Trim"	Selects Trim Control. Selects the 4-20mA Input.
8 "Comm, Trim"	Selects Trim Control. The reference word from a communication network such as Modbus RTU or DeviceNet becomes the PID Reference. The value sent over the network is scaled so that P035 [Maximum Freq] x 10 = 100% reference. For example, with [Maximum Freq] = 60 Hz, a value of 600 sent over the network would represent 100% reference.

PID Feedback Sel (A133) is used to select the source of the PID feedback.

Table I.2 – PID Feedback Sel (A133) Options

Option	Description
0 "0-10V Input"	Selects the 0-10V Input (default setting). Note that the PID will not function with a bipolar analog input. It will ignore any negative voltages and treat them like a zero.
1 "4-20mA Input"	Selects the 4-20mA Input.
2 "Comm Port"	The reference word from a communication network such as Modbus RTU or DeviceNet becomes the PID Feedback. The value sent over the network is scaled so that $P035 [Maximum\ Freq] \times 10 = 100\% \text{ Feedback}$ . For example, with $[Maximum\ Freq] = 60\ \text{Hz}$ , a value of 600 sent over the network would represent 100% Feedback.

## Analog PID Reference Signals

Parameters Anlg In 0-10V Lo (A110) and Anlg In 0-10V Hi (A111) are used to scale or invert an analog PID Reference.

**Important:** Firmware version FRN 1.xx does not support PID Feedback scaling from an analog input.

## Examples

### Scale Function

For a 0-5 volt signal, the following parameter settings are used so that a 0 volt signal = 0% PID Reference and a 5 volt signal = 100% PID Reference.

- Anlg In 0-10V Lo (A110) = 0.0%
- Anlg In 0-10V Hi (A111) = 50.0%
- PID Ref Sel (A132) = 0 "0-10V Input"

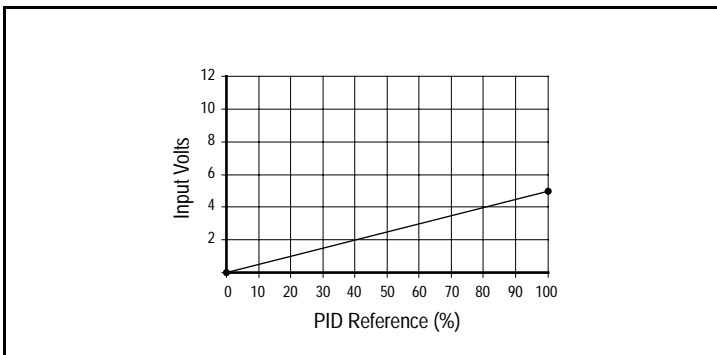

## Invert Function

For a 4-20mA signal, the following parameter settings are used so that a 20mA signal = 0% PID Reference and a 4mA signal = 100% PID Reference.

- Anlg In 4-20mA Lo (A112) = 100.0%
- Anlg In 4-20mA Hi (A113) = 0.0%
- PID Ref Sel (A132) = 3 "4-20mA Input"

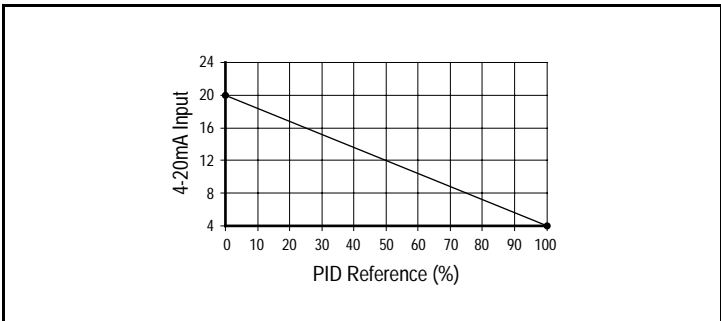

## PID Deadband

Parameter A138 [PID Deadband] is used to set a range, in percent, of the PID Reference that the drive will ignore.

### Example

- [PID Deadband] is set to 5.0
- The PID Reference is 25.0%
- The PID Regulator will not act on a PID Error that falls between 20.0 and 30.0%

## PID Preload

The value set in PID Preload (A139), in Hertz, will be pre-loaded into the integral component of the PID at any start or enable. This will cause the drive's frequency command to initially jump to that preload frequency, and the PID loop starts regulating from there.

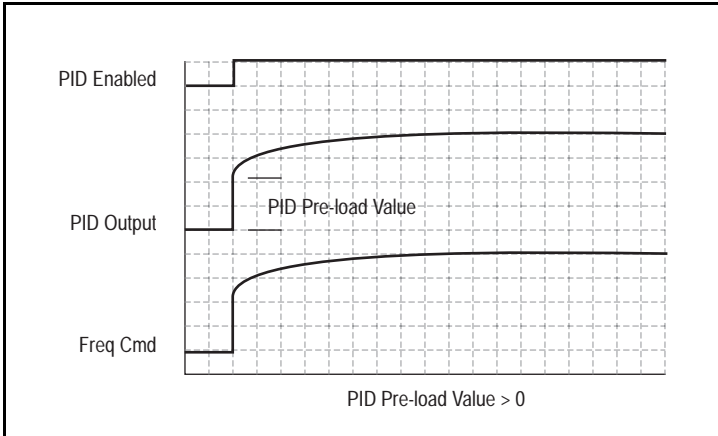

## PID Limits

PID Trim Hi (A130) and PID Trim Lo (A131) are used to limit the PID output and are only used in trim mode. PID Trim Hi (A130) sets the maximum frequency for the PID output in trim mode. PID Trim Lo (A131) sets the reverse frequency limit for the PID output in trim mode. Note that when the PID reaches the Hi or Lo limit, the PID regulator stops integrating so that windup does not occur.

## PID Gains

The proportional, integral, and differential gains make up the PID regulator.

- **PID Prop Gain (A134)**  
The proportional gain (unitless) affects how the regulator reacts to the magnitude of the error. The proportional component of the PID regulator outputs a speed command proportional to the PID error. For example, a proportional gain of 1 would output 100% of max frequency when the PID error is 100% of the analog input range. A larger value for PID Prop Gain (A134) makes the proportional component more responsive, and a smaller value makes it less responsive. Setting PID Prop Gain (A134) to 0.00 disables the proportional component of the PID loop.
- **PID Integ Time (A135)**  
The integral gain (units of seconds) affects how the regulator reacts to error over time and is used to get rid of steady state error. For example, with an integral gain of 2 seconds, the output of the integral gain component would integrate up to 100% of max frequency when the PID error is 100% for 2 seconds. A larger value for PID Integ Time (A135) makes the integral component less responsive, and a smaller value makes it more responsive. Setting PID Integ Time (A135) to 0 disables the integral component of the PID loop.
- **PID Diff Rate (A136)**  
The Differential gain (units of 1/seconds) affects the rate of change of the PID output. The differential gain is multiplied by the difference between the previous error and current error. Thus, with a large error the D has a large effect and with a small error the D has less of an effect. This parameter is scaled so that when it is set to 1.00, the process response is 0.1% of Maximum Freq (P035) when the process error is changing at 1% / second. A larger value for PID Diff Rate (A136) makes the differential term have more of an effect and a small value makes it have less of an effect. In many applications, the D gain is not needed. Setting PID Diff Rate (A136) to 0.00 (factory default) disables the differential component of the PID loop.

## Guidelines for Adjusting the PID Gains

1. Adjust the proportional gain. During this step it may be desirable to disable the integral gain and differential gain by setting them to 0. After a step change in the PID Feedback:
  - If the response is too slow increase PID Prop Gain (A134).
  - If the response is too quick and/or unstable (see Figure F.1), decrease PID Prop Gain (A134).
  - Typically, PID Prop Gain (A134) is set to some value below the point where the PID begins to go unstable.
2. Adjust the integral gain (leave the proportional gain set as in Step 1). After a step change in the PID Feedback:
  - If the response is too slow (see Figure F.2), or the PID Feedback does not become equal to the PID Reference, decrease PID Integ Time (A135).
  - If there is a lot of oscillation in the PID Feedback before settling out (see Figure F.3), increase PID Integ Time (A135).
3. At this point, the differential gain may not be needed. However, if after determining the values for PID Prop Gain (A134) and PID Integ Time (A135):
  - Response is still slow after a step change, increase PID Diff Rate (A136).
  - Response is still unstable, decrease PID Diff Rate (A136).

The following figures show some typical responses of the PID loop at different points during adjustment of the PID Gains.

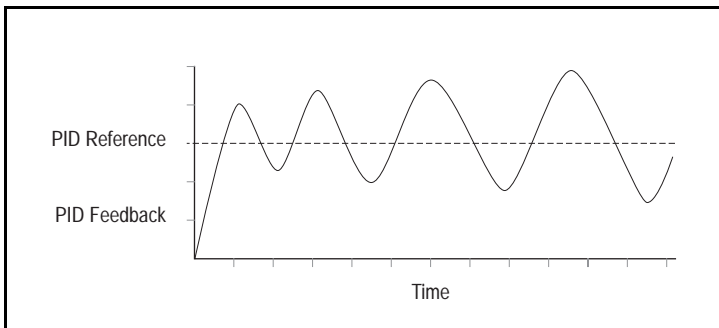

Figure I.1 – Unstable



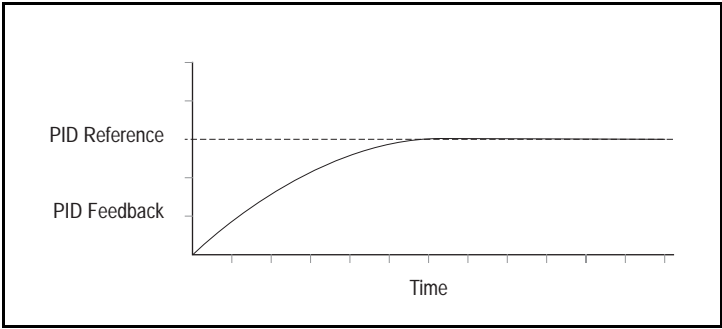

Figure I.2 – Slow Response - Over Damped

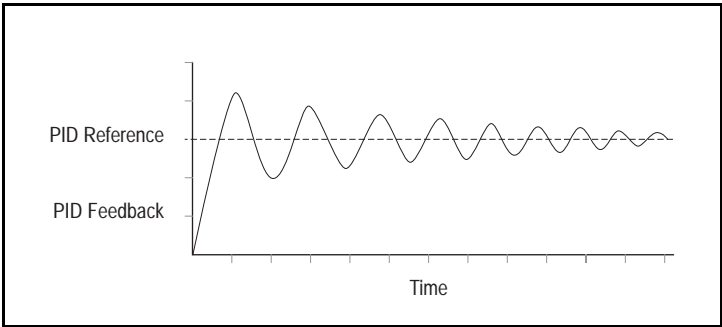

Figure I.3 – Oscillation - Under Damped

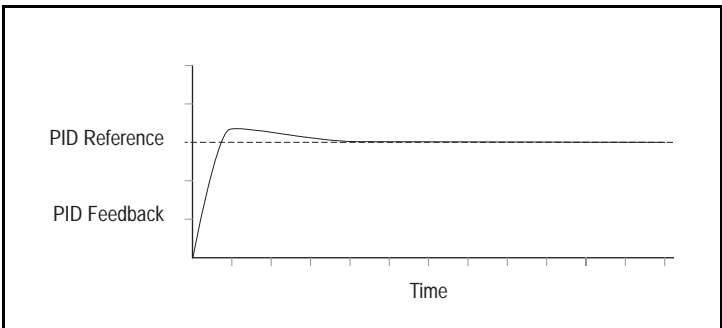

Figure I.4 – Good Response - Critically Damped



## Numerics

10V Bipolar Enbl (A123), 9-36

## A

A parameters, 9-8 to 9-34  
 Accel Time 1 (P039), 9-6  
 Accel Time 2 (A067), 9-18  
 accel/decel selection, 6-11  
 accessories, 2-3, E-1 to E-9  
 Advanced parameters, 9-8 to 9-34  
 Analog In 0-10V (d020), 9-51  
 Analog In Loss (A122), 9-35  
 Analog Input 4-20mA (d021), 9-51  
 Analog Input Loss fault, 10-4  
 Analog Out High (A066), 9-18  
 Analog Out Sel (A065), 9-17  
 Anlg Out Setpoint (A109), 9-32  
 Anlg In 0-10V Hi (A111), 9-32  
 Anlg In 0-10V Lo (A110), 9-32  
 Anlg In4-20mA Hi (A113), 9-33, 9-34  
 Anlg In4-20mA Lo (A112), 9-33  
 Auto Restart feature, 10-2  
 Auto Restart Tries fault, 10-4  
 Auto Rstrt Delay (A093), 9-27  
 Auto Rstrt Tries (A092), 9-26  
 Autotune (A127), 9-37  
 Auxiliary Input fault, 10-3

## B

Basic Logic, H-1  
 Basic parameters, 9-2 to 9-7  
 Bezel Kit, 2-4, E-7, E-9  
 Boost Select (A084), 9-23  
 Break Frequency (A087), 9-25  
 Break Voltage (A086), 9-24

## C

cables, 2-3  
 CE conformance requirements, D-1 to D-3  
 circuit breakers, 5-6 to 5-8, A-2

Comm Data Rate (A103), 9-30  
 Comm Format (A107), 9-31  
 Comm Loss Action (A105), 9-30  
 Comm Loss fault, 10-5  
 Comm Loss Time (A106), 9-31  
 Comm Node Addr (A104), 9-30  
 Comm Status (d015), 9-50  
 Commanded Freq (d002), 9-46  
 Compensation (A097), 9-28  
 Contrl In Status (d013), 9-49  
 control and signal wiring  
     recommendations, 6-3  
 Control Source (d012), 9-48  
 Control SW Ver (d016), 9-50  
 control terminal block  
     wiring, 6-4  
 control wiring, installing, 6-1 to 6-11  
 control, 2- and 3-wire, 6-9  
 Counter Functions, H-1  
 Counter Status (d025), 9-52  
 cover, opening, 5-1  
 Current Limit 1 (A089), 9-25  
 Current Limit 2 (A118), 9-34

## D

d parameters, 9-46 to 9-51  
 DB Resistor Sel (A082), 9-22  
 DC Brake Level (A081), 9-21  
 DC Brake Time (A080), 9-21  
 DC Bus Voltage (d005), 9-47  
 Decel Time 1 (P040), 9-6  
 Decel Time 2 (A068), 9-18  
 DeviceNet Communication Module, 2-3  
 Digital In1 Sel (A051), 9-8  
 Digital In2 Sel (A052), 9-8  
 Digital In3 Sel (A053), 9-8  
 Digital In4 Sel (A054), 9-8  
 dimensions, drive, 3-3  
 display description, 8-2  
 Display parameters, 9-46 to 9-51  
 drive  
     catalog numbers, 2-2  
     frame size, 2-2  
     grounding, 4-1 to 4-2

- model numbers, 2-2
- mounting, 3-1 to 3-6
- operating conditions, 3-2
- powering up after installing, 7-2
- ratings, 2-2
- storage guidelines, 2-4
- troubleshooting, 10-1 to 10-11

Drive Overload fault, 10-5

Drive Status (d006), 9-47

Drive Temp (d024), 9-52

Drive Type (d017), 9-50

Dynamic Brake Modules, E-2

## E

Elapsed Run Time (d018), 9-50

EMC Line Filters, E-4

## F

fault

- buffers, *see*, Fault n Code (d007-d009)

- clearing automatically, 10-2

- clearing manually, 10-2

- codes, about, 10-1

- descriptions and corrective actions, 10-3

- log, *see*, Fault n Code (d007-d009)

Fault 1 Code (d007), 9-47

Fault 2 Code (d008), 9-47

Fault 3 Code (d009), 9-47

Fault Clear (A100), 9-29

faults

- Analog Input Loss, 10-4

- Auto Restart Tries, 10-4

- Auxiliary Input, 10-3

- Comm Loss, 10-5

- Drive Overload, 10-5

- Ground Fault, 10-4

- Heatsink OverTemp, 10-4

- HW OverCurrent, 10-4

- I/O Board Fail, 10-6

- Motor Overload, 10-3

- Motor Stalled, 10-3

- OverVoltage, 10-3

- Parameter Checksum, 10-6

- Params Defaulted, 10-5

- Phase Short, 10-5

- Phase to Ground Short, 10-4

- Phase UW Short, 10-5

- Phase V to Gnd, 10-4

- Phase VW Short, 10-5

- Phase W to Gnd, 10-4

- Power Loss, 10-3

- Power Unit, 10-5

- SVC Autotune, 10-5

- SW OverCurrent, 10-5

- UnderVoltage, 10-3

filter, RFI, 4-2

Flux Current Ref (A129), 9-38

Flying Start En (A096), 9-28

frames and ratings, 2-2

fuses, 5-6 to 5-8, A-2

## G

Ground Fault, 10-4

ground fault monitoring, 4-1

grounding the drive, 4-1 to 4-2

## H

Heatsink OverTemp fault, 10-4

HW OverCurrent fault, 10-4

## I

I/O Board Fail fault, 10-6

I/O wiring, 6-4

I/O wiring examples, 6-6, 6-9

input potentiometer, 6-6

input power conditioning, 5-4

installation, 7-1

Internal Freq (A069), 9-19

IR Voltage Drop (A128), 9-38

## J

Jog Accel/Decel (A079), 9-21

Jog Frequency (A078), 9-20

jumper, removing, 5-3

## K

key descriptions, 8-3

keypad components, 8-1

kits, 2-3

## L

Language (A108), 9-31

LED descriptions, 8-2

## M

- Maximum Freq (P035), 9-2
- Maximum Voltage (A088), 9-25
- Minimum Freq (P034), 9-2
- model numbers, 2-1
- motor cable length, 5-10
- motor cable types, 200-600 V
  - installations, 5-8
- Motor NP FLA (A126), 9-37
- Motor NP Hertz (P032), 9-2
- Motor NP Volts (P031), 9-2
- Motor OL Current (P033), 9-2
- Motor OL Select (A090), 9-25
- Motor Overload fault, 10-3
- Motor Stalled fault, 10-3
- motor start/stop precautions, 6-2
- mounting specifications, 3-6
- mounting the drive, 3-1 to 3-6
- MOVs, 5-3
- multiple drive connection examples, 6-9

## N

- NEMA 1/IP30 Kit., 2-3

## O

- OIMs, E-7
- operating conditions, 3-2
- Operator Interface Modules (OIMs), E-7
- Opto Out Logic (A064), 9-16
- Opto Out1 Level (A059), 9-16
- Opto Out1 Sel (A058), 9-14
- Opto Out2 Level (A062), 9-16
- Opto Out2 Sel (A061), 9-14
- Output Current (d003), 9-46
- output disconnect, 5-10
- Output Freq (d001), 9-46
- Output Power (d022), 9-51
- Output Power Fctr (d023), 9-51
- Output Torque Current (d029), 9-52
- Output Voltage (d004), 9-46
- OverVoltage fault, 10-3

## P

- P parameters, 9-2 to 9-7
- Parameter Checksum fault, 10-6
- Parameter Groups, 8-4
- parameters
  - A, 9-8 to 9-34

- about, 8-4
- Advanced, 9-8 to 9-34
- Basic, 9-2 to 9-7
- cross-referenced by name, C-1 to C-5
- d, 9-46 to 9-51
- descriptions, 9-1 to 9-51
- Display, 9-46 to 9-51
- P, 9-2 to 9-7
- record of user settings, B-1 to B-5
- viewing and adjusting Basic (P) and Advanced (A), 8-5
  - viewing Display (d), 8-6
- Params Defaulted fault, 10-5
- PE ground, 4-2
- Phase Short fault, 10-5
- Phase to Ground fault, 10-4
- Phase UW Short fault, 10-5
- Phase V to Gnd fault, 10-4
- Phase VW Short fault, 10-5
- Phase W to Gnd fault, 10-4
- PID Deadband (A138), 9-40
- PID Diff Rate (A136), 9-40
- PID Feedback Sel (A133), 9-39
- PID Integ Time (A135), 9-40
- PID Preload (A139), 9-40
- PID Prop Gain (A134), 9-39
- PID Ref Select (A132), 9-39
- PID Set Up, I-1
- PID Setpoint (A137), 9-40, 9-44, 9-45, 9-46
- PID Trim Hi (A130), 9-38
- PID Trim Lo (A131), 9-39
- potentiometer, wiring, 6-6
- Power Loss fault, 10-3
- power terminal block
  - connections, 5-5
  - specifications, 5-5
- Power Unit fault, 10-5
- power wiring specifications, 5-9
- power wiring, installing, 5-1 to 5-10
- power-off checks, 7-1
- Preset Freq 0 (A070), 9-20
- Preset Freq 1 (A071), 9-20
- Preset Freq 2 (A072), 9-20
- Preset Freq 3 (A073), 9-20
- Preset Freq 4 (A074), 9-20
- Preset Freq 5 (A075), 9-20
- Preset Freq 6 (A076), 9-20
- Preset Freq 7 (A077), 9-20
- Process Display (d010), 9-48
- Display Scaling, 9-29
- Process Factor (A099), 9-29

Program Lock (A101), 9-29  
protective features, A-3  
PWM Frequency (A091), 9-26

## R

Reflected Wave Protection, 5-10  
reflected wave protection, 5-10  
Relay Out Sel (A055), 9-11  
Relay Output Level (A056), 9-13  
Reliance Electric, contacting, 1-1  
Remote Handheld OIM, 2-4  
Remote Panel-Mount OIM, 2-3  
Reset to Defaults (P041), 9-7  
Reverse Disable (A095), 9-27  
RFI filter grounding, 4-2  
RJ45 Splitter Cable, G-1 to G-4, G-1 to  
??  
RS485 (MDI) protocol, F-1 to F-8

## S

S Curve % (A083), 9-22  
safety ground, 4-2  
Serial Converter Module, 2-3  
shield termination, 4-2  
shielded motor cable, 5-9  
Skip Freq Band (A120), 9-34  
Skip Frequency (A119), 9-34  
Slip Hertz @ FLA (A114), 9-33  
specifications, technical, A-1  
Speed Reference (P038), 9-5  
speed reference control, 6-10  
Stall Fault Time (A121), 9-35  
Start At PowerUp (A094), 9-27  
Start Boost (A085), 9-24  
Start Source (P036), 9-3  
starting up the drive, 7-1  
StepLogicTM, H-1  
stop circuit requirements, 6-1  
Stop Mode (P037), 9-4  
storage guidelines, 2-4  
Stp Logic 0 (A140), 9-41  
Stp Logic 1 (A141), 9-41  
Stp Logic 2 (A142), 9-41  
Stp Logic 3 (A143), 9-41

Stp Logic 4 (A144), 9-41  
Stp Logic 5 (A145), 9-41  
Stp Logic 6 (A146), 9-41  
Stp Logic 7 (A147), 9-41  
Stp Logic Status (d028), 9-52  
SVC Autotune fault, 10-5  
SW Current Trip (A098), 9-28  
SW OverCurrent fault, 10-5

## T

technical assistance, 1-1  
terminal block  
control, 6-4  
power, 5-5  
Testpoint Data (d019), 9-51  
Testpoint Select (A102), 9-29  
three-wire control, 6-9  
Time Functions, H-1  
Timer Status (d026), 9-52  
Torque Perf Mode (A125), 9-37  
troubleshooting tables, 10-7 to 10-11  
troubleshooting the drive, 10-1 to 10-11  
two-wire control, 6-9

## U

UnderVoltage fault, 10-3  
ungrounded distribution systems, 5-2  
unshielded power cables, 5-8

## V

Var PWM Disable (A124), 9-36  
VS Utilities Software, 2-3

## W

weight, drive, 3-3  
wiring  
I/O examples, 6-9  
potentiometer, 6-6  
wiring specifications  
control and signal, 6-3  
power, 5-9

# DIF

## Documentation Improvement Form

Use this form to give us your comments concerning this publication or to report an error that you have found. For convenience, you may attach copies of the pages with your comments. After you have completed this form, please return it to:

Reliance Electric  
Standard Drives - Technical Documentation  
6040 Ponders Court  
Greenville, SC 29617

Fax: 864-284-5483

Publication Name: <b>MD65 AC Drive User Manual</b>	
Publication Number: <b>D2-3519-2</b>	Publication Date: April 2004

Comments:

---

---

---

---

---

Your Name:	Date:
Company Name:	Phone: (    )
Address:	
E-mail:	

Thank you for your comments.

<b>Technical Writing Internal Use</b>	
Date:	DIF Number:
Follow-Up Action:	

# Rockwell Automation







This document, as well as more information about Reliance Electric products, can be found at [www.reliance.com/drives](http://www.reliance.com/drives).

[www.rockwellautomation.com](http://www.rockwellautomation.com)

**Corporate Headquarters**

Rockwell Automation, 777 East Wisconsin Avenue, Suite 1400, Milwaukee, WI, 53202-5302 USA, Tel: (1) 414.212.5200, Fax: (1) 414.212.5201

**Headquarters for Dodge and Reliance Electric Products**

Americas: Rockwell Automation, 6040 Ponders Court, Greenville, SC 29615-4617 USA, Tel: (1) 864.297.4800, Fax: (1) 864.281.2433

Europe: Rockwell Automation, Brühlstraße 22, D-74834 Elztal-Dallau, Germany, Tel: (49) 6261 9410, Fax: (49) 6261 1774

Asia Pacific: Rockwell Automation, 55 Newton Road, #11-01/02 Revenue House, Singapore 307987, Tel: (65) 351 6723, Fax: (65) 355 1733

Reliance Electric Standard Drives Business, P.O. Box 248019, Mayfield Heights, OH 44124-8019 USA. Tel: (1) 888.374.8370, Fax: 440.646.7317

Publication D2-3519-2 April 2004

© 2004 Rockwell Automation. All rights reserved. Printed in USA.