

# 4 Output 4-20 mA Analog Rail Module

M/N 61C365

---

Instruction Manual J-3694-2

---

**RELIANCE  
ELECTRIC** 

The information in this user's manual is subject to change without notice.

**DANGER**

**ONLY QUALIFIED ELECTRICAL PERSONNEL WHO ARE FAMILIAR WITH THE CONSTRUCTION AND OPERATION OF THIS EQUIPMENT AND THE HAZARDS INVOLVED SHOULD INSTALL, ADJUST, OPERATE, AND/OR SERVICE THIS EQUIPMENT. READ AND UNDERSTAND THIS MANUAL IN ITS ENTIRETY BEFORE PROCEEDING. FAILURE TO OBSERVE THIS PRECAUTION COULD RESULT IN SEVERE BODILY INJURY OR LOSS OF LIFE.**

**WARNING**

**INSERTING OR REMOVING THIS PRODUCT OR ITS CONNECTING CABLES MAY RESULT IN UNEXPECTED MACHINE MOTION. POWER TO THE MACHINE SHOULD BE TURNED OFF BEFORE INSERTING OR REMOVING THE PRODUCT OR ITS CONNECTING CABLES. FAILURE TO OBSERVE THIS PRECAUTION COULD RESULT IN BODILY INJURY.**

AutoMax®, AutoMate®, and Reliance® are registered trademarks of Reliance Electric Company or its subsidiaries.

Belden® is a registered trademark of Belden, Inc.

# Table of Contents

<b>1.0</b>	<b>Introduction</b> .....	<b>1-1</b>
1.1	Additional Information .....	1-1
1.2	Related Hardware and Software .....	1-2
<b>2.0</b>	<b>Mechanical/Electrical Description</b> .....	<b>2-1</b>
2.1	Mechanical Description .....	2-1
2.2	Electrical Description .....	2-3
<b>3.0</b>	<b>Installation</b> .....	<b>3-1</b>
3.1	Wiring .....	3-1
3.2	Initial Installation .....	3-2
3.3	Module Replacement .....	3-6
<b>4.0</b>	<b>Programming</b> .....	<b>4-1</b>
4.1	Analog Rail Module in AutoMate Systems .....	4-1
4.1.1	Configuring the AutoMate Processor for Use with the Analog Rail Module .....	4-1
4.1.2	AutoMate Programming in Rail Mode .....	4-7
4.1.3	AutoMate Programming in Local Head Mode .....	4-7
4.1.4	Analog Out (AOUT) Instruction Block .....	4-8
4.2	Analog Rail Module in DCS 5000/AutoMax Systems .....	4-9
4.2.1	Configuring the Analog Rail Module with a DCS 5000/AutoMax Remote I/O Head .....	4-9
4.2.2	Configuring the Analog Rail Module with a Power Module Interface Processor Host .....	4-10
<b>5.0</b>	<b>Diagnostics and Troubleshooting</b> .....	<b>5-1</b>
5.1	Both LEDs on the Faceplate are Off .....	5-1
5.2	The “COM OK” LED is Off .....	5-3
5.3	Incorrect Data .....	5-3

# Appendices

<b>Appendix A</b>	
Technical Specifications .....	A-1
<b>Appendix B</b>	
Block Diagram .....	B-1
<b>Appendix C</b>	
Sample AutoMate Program .....	C-1

# List of Figures

Figure 1.1	- Analog Rail Module Hardware Configuration	1-3
Figure 2.1	- Analog Rail Module Faceplate	2-2
Figure 2.2	- Typical Output Circuit	2-4
Figure 3.1	- Mounting Dimensions	3-2
Figure 3.2	- Typical Recommended Output Shielding Methods	3-5
Figure 4.1	- Configuration for Analog Rail Module with AutoMate 20	4-2
Figure 4.2	- Sample Configurations for Analog Rail Module Connected Directly to AutoMate 30 or 40	4-3
Figure 4.3	- Sample Configuration for Analog Rail Module Connected to AutoMate 30 or 40 Through Local I/O Head	4-4
Figure 4.4	- Sample Configuration for Analog Rail Module with AutoMate Local I/O Processor	4-5
Figure 4.5	- Sample Configuration for Analog Rail Module with AutoMate Remote I/O Head	4-6
Figure 4.6	- Rail Mode Register Image for Output Channels	4-7
Figure 4.7	- Local Head Register Image for Output Channels	4-8
Figure 4.8	- AOUT Instruction Block	4-9



# 1.0 INTRODUCTION

The products described in this instruction manual are manufactured by Reliance Electric Industrial Company.

The 4 Output 4-20 mA Analog Rail module allows you to output four 4-20 mA analog signals from AutoMate®, AutoMax® and DCS 5000 systems. Typically, the Analog Rail module is used with potentiometers, valve actuators, pressure or flow transducers, and meters in both drive control systems and process control systems.

The Analog Rail module is hardware-configurable by means of a faceplate switch to emulate one of two types of devices, AutoMate Rails or AutoMate Local Heads. In some hardware configurations, the type of interface device available for the Analog Rail module will determine the mode of operation that can be selected (see figure 1.1).

The Analog Rail module operates in Local Head mode when it is connected directly to one of the processor's four I/O ports in AutoMate systems, to an AutoMate Local I/O Processor, or to one of the four I/O ports of the DCS 5000/AutoMax Remote I/O Head in DCS 5000/AutoMax systems. The Analog Rail data will take up four registers in the host when operating in Local Head mode.

The module operates in Rail mode when it is connected to one I/O port of a Local I/O Head, which in turn is connected to one I/O port of an AutoMate processor. The Analog Rail module will occupy one register of the host in Rail mode. The Rail mode is used to expand the I/O address space available through the front I/O port of the processor by multiplexing each group of four analog points through one register. Note that the Analog Rail module cannot be used with the Local I/O Head in DCS 5000/AutoMax systems.

The Analog Rail module operates in Rail mode when it is connected to one I/O port of the Power Module Interface (PMI) Processor (B/M 60000), which is in turn connected to a Universal Drive Controller (UDC) module (M/N 57552) which resides in an AutoMax rack.

The remainder of this manual describes the functions and specifications of the module. It also includes a detailed overview of installation and troubleshooting procedures, as well as examples of configuration and programming.

## 1.1 Additional Information

You must become familiar with the instruction manuals which describe your system configuration. This may include, but is not limited to, the following:

- J-3031 AutoMate 30 PROCESSOR HARDWARE INSTRUCTION MANUAL
- J-3033 AutoMate LOCAL I/O PROCESSOR INSTRUCTION MANUAL
- J-3037 AutoMate REMOTE I/O HEAD INSTRUCTION MANUAL
- J-3063 AutoMate PROGRAMMING EXECUTIVE INSTRUCTION MANUAL
- J-3120 AutoMate 20 USER'S MANUAL

- J-3141 AutoMate 40 CONTROL PROCESSOR INSTRUCTION MANUAL
- J-3150 AutoMate 30/40 SOFTWARE REFERENCE MANUAL
- J-3649 DCS 5000/AutoMax CONFIGURATION TASK INSTRUCTION MANUAL
- J-3630 AutoMax PROGRAMMING EXECUTIVE INSTRUCTION MANUAL
- J-3600 DCS 5000 ENHANCED BASIC LANGUAGE INSTRUCTION MANUAL
- J-3675 AutoMax ENHANCED BASIC LANGUAGE INSTRUCTION MANUAL
- J-3601 DCS 5000 CONTROL BLOCK LANGUAGE INSTRUCTION MANUAL
- J-3676 AutoMax CONTROL BLOCK LANGUAGE INSTRUCTION MANUAL
- J-3602 DCS 5000 LADDER LOGIC LANGUAGE INSTRUCTION MANUAL
- J-3677 AutoMax LADDER LOGIC LANGUAGE INSTRUCTION MANUAL
- J-3671 AutoMate LOCAL I/O HEAD INSTRUCTION MANUAL
- J-3750 AutoMax PROGRAMMING EXECUTIVE INSTRUCTION MANUAL VERSION 3.0
- J2-3045 AutoMax PROGRAMMING EXECUTIVE VERSION 3.3
- S-3006 D-C DRIVE CONFIGURATION AND PROGRAMMING INSTRUCTION MANUAL
- S-3008 POWER MODULE INTERFACE RACK INSTRUCTION MANUAL
- Your personal computer and DOS operating system manual(s).
- IEEE 518 GUIDE FOR THE INSTALLATION OF ELECTRICAL EQUIPMENT TO MINIMIZE ELECTRICAL NOISE INPUTS TO CONTROLLERS

## 1.2 Related Hardware and Software

The 4 Output 4-20 mA Analog Rail module, M/N 61C365, contains the following:

1. One 4 Output 4-20 mA Analog Rail module
2. One I/O Rail cable: M/N 45C5
3. Two plug connectors: 12-point connector part no. 419434-2R  
4-point connector part no. 419434-1R
4. One .25A fuse (installed in the module): part no. 64676-23J
5. One .75A fuse (required for operation on 24 VDC):  
part no. 64676-23Q
6. Two cable retainer clips



The Analog Rail module can be configured with the hardware (purchased separately) listed in figure 1.1.

<b>Host</b>	<b>Model</b>	<b>Operating Mode</b>
DCS 5000/AutoMax Remote I/O Head	M/N 57C330	Local Head
AutoMate 20, 20E	M/N 45C20, 45C21, 45C220, 45C221, 45C224, 45C225	Local Head or Rail *
AutoMate 30, 30E	M/N 45C301, 45C305, 45C307	Local Head or Rail *
AutoMate 40, 40E	M/N 45C410, 45C411	Local Head or Rail *
AutoMate Local I/O Processor	M/N 45C200B (and later versions)	Local Head
AutoMate Remote I/O Head	M/N 45C37, 45C38	Local Head
Power Module Interface Processor	B/M 60000	Rail
* Direct connection to the Processors (Local Head mode) or connection through an AutoMate Local I/O Head, M/N 45C22, 61C22, 61C22A, or 61C23 (Rail mode). Note that it is also permissible to configure the Analog Rail module for Rail mode even if it is connected directly to an AutoMate 20, 30, or 40 Processor.		

Figure 1.1 - Analog Rail Module Hardware Configuration



## **2.0 MECHANICAL/ELECTRICAL DESCRIPTION**

The following sections describe the mechanical and electrical characteristics of the Analog Rail module.

### **2.1 Mechanical Description**

The Analog Rail module is a self-contained electronic module containing two dual digital-to-analog converters providing four output channels. The module is housed in a protective metal enclosure designed for panel mounting. See figure 2.1.

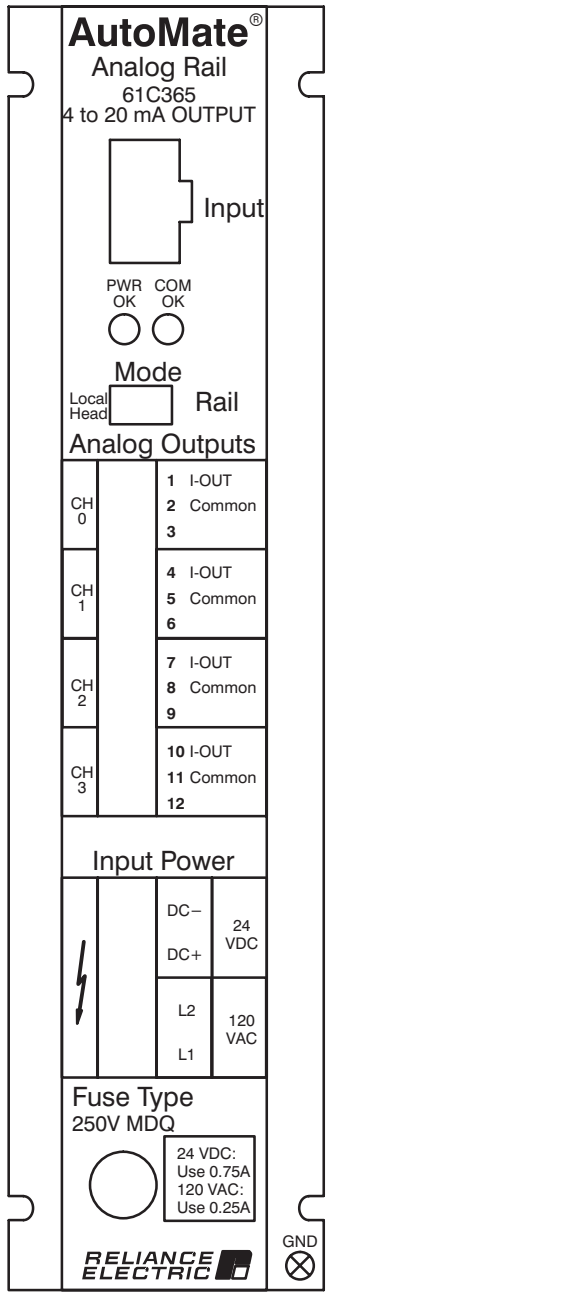

Figure 2.1 - Analog Rail Module Faceplate

The faceplate of the module contains three electrical connectors labeled “Input”, “Analog Outputs”, and “Input Power” (reading top to bottom). The top connector is used for connection to the I/O port. A cable (M/N 45C5) is provided for this purpose. The second connector, labeled “Analog Outputs”, is a numbered, 12-point removable plug connector with screw-type terminal points. Three successive terminal points are reserved for each channel’s connection to external hardware. The “Analog Output” terminals are designed for 14-22 AWG wire.

The third connector on the faceplate, also a removable plug connector with screw-type terminal points, is used for input power. The terminal points are labeled. The top two points are used if the power source is 24 VDC. The bottom two points are used if the power source is 120 VAC. The “Input Power” terminals are designed to use 14 AWG wire. A terminal stud for connecting a grounding conductor is provided on the bottom of the right-hand mounting flange.

The module faceplate also contains two LEDs, a mode switch, and a fuse holder and fuse. The LED labeled “PWR OK” indicates that the I/O port, the external power source, and the internally-generated voltages necessary for operation of the module are present. The “COM OK” LED indicates whether all four channels are successfully communicating with the host.

The switch labeled “Mode” is used to select between “Local Head” and “Rail” mode. Note that the position of the switch is read only once at the time power is turned on to the Reliance device that is connected to the Analog Rail module. The mode will remain fixed as long as this device is powered up.

**As shipped from the factory, the fuse holder on the bottom of the faceplate contains a .25A fuse for 120 VAC input power. If input power will be 24 VDC, you need to replace the fuse with the .75A fuse included along with the Analog Rail module.**

## 2.2 Electrical Description

The Analog Rail module contains four output channels that can output 4-20mA analog signals proportional to an input value of 0 to 4095. A user-supplied power supply in series with the external hardware is required for the output channels. Note that at a digital output = 4096, the output rolls over to zero again. Negative output values cannot be accommodated.

The D/A conversions are triggered by the actual I/O update sequences. The conversion rate is therefore dependent upon the scan time of the application task. See figure 2.2 for a typical output circuit.

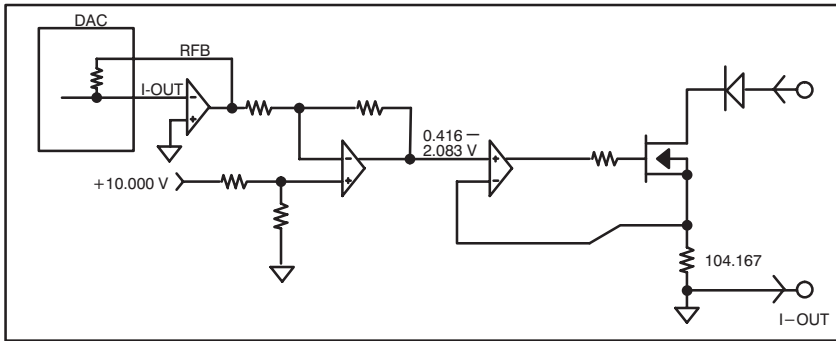

Figure 2.2 - Typical Output Circuit

The Analog Rail module is factory calibrated and requires no offset/gain adjustment. All four analog output channels are referenced to the same common. This common is isolated from both the external power supply and the I/O port connection.

The module incorporates extensive diagnostics. In Rail mode, check bits are monitored for accuracy on every transfer of data between the processor and the module. In Local Head mode, parity bits are monitored for accuracy on every transfer of data. A Rail fault LED on the processor, Remote Head, or Local Head will be illuminated if the check bits or parity bits are wrong and all transmission will stop after  $n$  retries, where  $n$  is a value determined by the host's software (average  $n = 4$  for AutoMax; AutoMate  $n = 2$ ).

In the event of a rail fault, all outputs will be set to 0. The "COM OK" LED on the module will go off. If any power required by the module, i.e., the +5 Volts from the I/O port required for communication, the external power supply, or the power required by the Analog Output section, is not within specified limits, all outputs will be set to 0 and the "PWR OK" LED will go off.

## 3.0 INSTALLATION

This section describes how to install and replace the Analog Rail module. Note that analog signals are sensitive to variations in temperature. The Analog Rail module is designed to perform optimally at room temperature, approximately 25°C. In all cases, the ambient temperature of the installation must be maintained in the range specified in Appendix A to ensure the highest possible accuracy.

### **DANGER**

**THE USER IS RESPONSIBLE FOR CONFORMING WITH THE NATIONAL ELECTRICAL CODE AND ALL OTHER APPLICABLE LOCAL CODES. WIRING PRACTICES, GROUNDING, DISCONNECTS, AND OVER-CURRENT PROTECTION ARE OF PARTICULAR IMPORTANCE. FAILURE TO OBSERVE THIS PRECAUTION COULD RESULT IN SEVERE BODILY INJURY OR LOSS OF LIFE.**

### **DANGER**

**DO NOT TOUCH THE CONNECTORS ON THE FACEPLATE IF THERE IS POWER ON THE WIRES ATTACHED TO THE PLUG CONNECTOR SCREW TERMINALS. ALWAYS TURN OFF POWER BEFORE HANDLING A CONNECTOR THAT IS WIRED. FAILURE TO OBSERVE THIS PRECAUTION COULD RESULT IN SEVERE BODILY INJURY OR LOSS OF LIFE.**

### **WARNING**

**UNEXPECTED OUTPUT CHANGES MAY RESULT IF AN ANALOG RAIL IS PLUGGED INTO A LOCAL I/O HEAD THAT IS COMMUNICATING WITH A PROCESSOR. ANY HARDWARE CONFIGURATION CHANGES MUST BE MADE ONLY WITH THE LOCAL I/O INTERFACE CABLE (M/N 45C8) DISCONNECTED. FAILURE TO OBSERVE THIS PRECAUTION COULD RESULT IN BODILY INJURY.**

### **CAUTION**

**THE ANALOG RAIL MODULE IS DESIGNED TO BE POWERED BY EITHER 24 VDC OR 120 VAC. CONNECT THE PROPER POWER SOURCE TO THE MODULE. FAILURE TO OBSERVE THIS PRECAUTION COULD RESULT IN DAMAGE TO OR DESTRUCTION OF THE EQUIPMENT.**

## 3.1 Wiring

To reduce the possibility of electrical noise interfering with the proper operation of the control system, exercise care when installing the wiring between the module and the external hardware.

Use shielded twisted pair for all wiring between the Analog Rail module and the external hardware. Belden™ 8761 or an equivalent cable type is recommended. For detailed recommendations refer to IEEE 518.

## 3.2 Initial Installation

Use the following procedure to install the Analog Rail module.

- Step 1. Using the mounting dimensions shown in figure 3.1, prepare the necessary mounting provisions on the panel. The module is designed to be mounted vertically using four #10 or M5 bolts or studs. Multiple modules should be mounted side by side. The flange width of two modules side by side is sufficient to dissipate the heat produced by the modules. The modules can also be mounted one above the other, but since this hardware configuration does not allow the most efficient heat dissipation, the minimum clearance between the module chassis is 3". See figure 3.1.

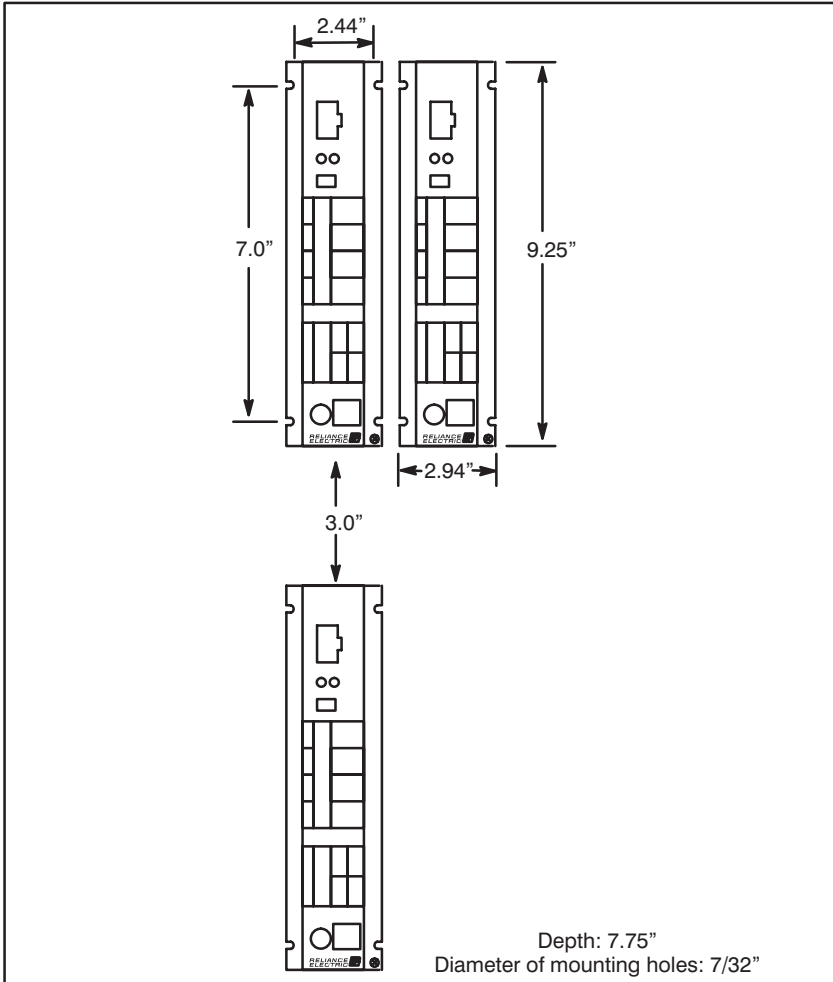

Figure 3.1 - Mounting Dimensions



- Step 2. If the power supply you are using is 24 VDC, replace the factory-installed .25A fuse with the .75A fuse that came in the shipping box with the module. Use a screwdriver to release the fuse holder located on the Analog Rail module faceplate. Pull the fuse holder out of the module. Take the .25A fuse out of the fuse holder and replace it with the .75A fuse. Re-insert the fuse holder into the module. Turn the screwdriver clockwise while pressing down on the fuse holder. The fuse holder must be flush against the faceplate.
- Step 3. Mount the Analog Rail on the panel and attach it securely to the wall with #10 (M5) studs or bolts.
- Step 4. Make certain that no voltage is present on the wires that will be used to provide 120 VAC or 24 VDC power to the Analog Rail module. Use either a 120 VAC or 24 VDC power supply, but not both.
- Step 5. Using 14 AWG wire, connect input power to the screw terminals on the “Input Power” plug connector on the faceplate as shown below. Strip off approximately 5/16” of insulation from the wires.

24 VDC Power

Signal	Terminal Label	Terminal Number
24 VDC –	DC–	1
24 VDC +	DC+	2

120 VAC Power

Signal	Terminal Label	Terminal Number
120 VAC – (neutral)	L2/N	3
120 VAC + (hot)	L1	4

- Step 6. Use the stud marked “GND” (ground) on the bottom right flange of the module to connect a ground wire.

**DANGER**

**THE USER IS RESPONSIBLE FOR CONFORMING WITH THE NATIONAL ELECTRICAL CODE AND ALL OTHER APPLICABLE LOCAL CODES. WIRING PRACTICES, GROUNDING, DISCONNECTS, AND OVER-CURRENT PROTECTION ARE OF PARTICULAR IMPORTANCE. FAILURE TO OBSERVE THIS PRECAUTION COULD RESULT IN SEVERE BODILY INJURY OR LOSS OF LIFE.**

- Step 7. Turn off all power to any external hardware that will provide input signals to the module or be powered by the module.
- Step 8. Attach a retainer clip to the connector at each end of the I/O Rail cable (M/N 45C5). Note that faceplate connectors have slots that correspond to the part of the retainer clip that protrudes away from the cable connector. The retainer clip is used to assure a tight connection between the cable and faceplate connectors.
- Step 9. Using 14-22AWG wire, connect external hardware to the “Analog Output” plug connector on the faceplate as shown below. Strip off approximately 5/16” insulation from the wires.

Channel	Terminal Number	Terminal Label	Signal
0	1 2 3	I-OUT Common (no label)	4-20mA+ output common (shield; no connection)*
1	4 5 6	I-OUT Common (no label)	4-20mA+ output common (shield; no connection)*
2	7 8 9	I-OUT Common (no label)	4-20mA+ output common (shield; no connection)*
3	10 11 12	I-OUT Common (no label)	4-20mA+ output common (shield; no connection)*

\*This terminal makes no electrical connection to the Analog Rail printed circuit board.

- Step 10. For each of the four output channels, connect a shield wire from the external hardware to the third terminal (terminals 3, 6, 9, and 12, respectively). The shield wire at the external hardware end of the cable should be connected to the source reference point. See figure 3.2.

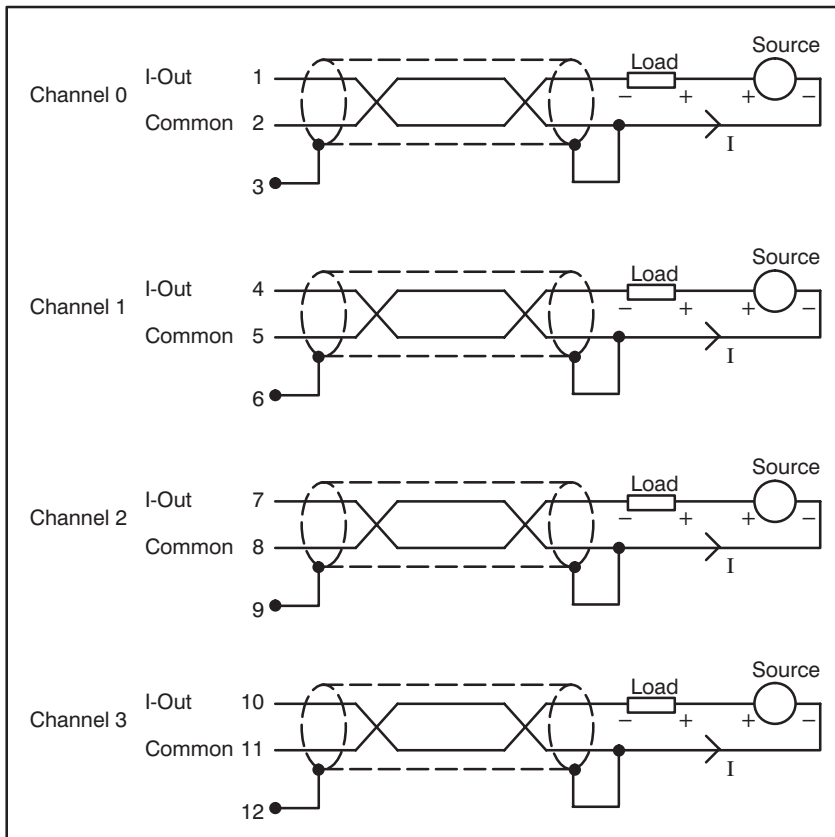

Figure 3.2 - Typical Recommended Output Shielding Methods

- Step 11. Turn off power to the Reliance device that will be connected to the Analog Rail module.
- Step 12. Set the "Mode" switch on the faceplate of the Analog Rail module to the desired position.
- Step 13. Connect the I/O Rail cable between the Analog Rail connection labeled "Input" and an I/O port on the Reliance device that will communicate with the module. Turn on power to the Reliance device that will communicate with the Analog Rail module. Recall that the Mode switch is read each time the Reliance device connected to the module is powered up.
- Step 14. The Analog Rail installation is now ready for testing. Inspect all work to assure that the installation has been performed properly.
- Step 15. Turn on power to the "Input Power" wiring. Turn on power to the external hardware. Recall that external hardware being powered by the output of the Analog Rail module must be in series with an external power supply. See figure 3.2. See Appendix A for the power supply specifications.

- Step 16. Verify that the hardware has been installed correctly. Before testing, insure that the external hardware will not respond to output signals from the Analog Rail module.

#### **WARNING**

**BE CAREFUL WHEN WRITING TO THE OUTPUTS TO INSURE THAT NO UNEXPECTED MACHINE MOTION WILL RESULT. FAILURE TO OBSERVE THIS PRECAUTION COULD RESULT IN BODILY INJURY OR DAMAGE TO EQUIPMENT.**

For AutoMate systems, you must configure the AutoMate processor using the AutoMate Programming Executive (APX) before testing. See section 4.0 for more information. After configuring the module, use the APX Point Monitor function to test the module. You can test the Analog Rail module output channels by writing a value between 0 and 4095 to those channels and, with an ammeter, verifying that the output on the terminal points (4-20mA) is proportional.

For DCS 5000, AutoMax, or Distributed Power D-C Drive systems, use the DCS 5000 or AutoMax Programming Executive software I/O Monitor function, respectively. Test output channels by writing a value between 0 and 4095 to those channels and using an ammeter to verify that the signal on the terminal points (4-20mA) is proportional.

### **3.3 Module Replacement**

Use the following procedure to replace the module.

- Step 1. Stop any application programs that are running.
- Step 2. Turn off power to the external hardware connected to the output channels on the faceplate of the module.
- Step 3. Turn off power to the Analog Rail module (120 VAC or 24 VDC).
- Step 4. Turn off power to the Reliance device connected to the Analog Rail module.
- Step 5. Disconnect the I/O Rail cable from the Analog Rail module.
- Step 6. Without disconnecting the wiring, remove the 12-point terminal from the faceplate and set aside.
- Step 7. Without disconnecting the wiring, remove the 4-point terminal from the faceplate and set aside. Disconnect the ground wire from the bottom of the right-hand flange.
- Step 8. Loosen the screws that hold the Analog Rail module to the panel and remove the module.
- Step 9. If the power supply you are using is 24 VDC, you need to replace the factory-installed .25A fuse in the new module with the .75A fuse that came in the shipping box with the module. Use a screwdriver to release the fuse holder located on the Analog Rail module faceplate. Pull the fuse holder out of the module.

Remove the .25A fuse from the fuse holder and replace it with the .75A fuse. Re-insert the fuse holder into the module. Turn the screwdriver clockwise while pressing down on the fuse holder at the same time. The fuse holder must be flush against the faceplate.

- Step 10. Remove the two plug connectors from the faceplate of the new module by pulling them firmly away from the faceplate.
- Step 11. Place the new module over the pattern drilled and attach it securely to the panel with #10 or M5 studs or bolts.
- Step 12. Attach the original 12-point and 4-point connectors with wiring to the faceplate of the module. Use the stud marked "GND" (ground) on the bottom right flange of the module to connect a ground wire.
- Step 13. Set the "Mode" switch on the faceplate to the desired position.
- Step 14. Connect the I/O Rail cable between the Analog Rail connection labeled "Input" and the I/O port. Turn on power to the Reliance device connected to the Analog Rail module. Recall that the Mode switch is read each time the Reliance device connected to the module is powered up. If applicable, re-connect the cable between the Local I/O Head, or the DCS 5000 Remote I/O Head, and the host.
- Step 15. Turn on power to the Analog Rail module "Input Power" connections.
- Step 16. Turn on power to the external hardware connected to the Analog Rail module.
- Step 17. Verify that the hardware has been installed correctly. Before testing, insure that the external hardware cannot respond to output signals from the Analog Rail module.

#### **WARNING**

**BE CAREFUL WHEN WRITING TO THE OUTPUTS TO INSURE THAT NO UNEXPECTED MACHINE MOTION WILL RESULT. FAILURE TO OBSERVE THIS PRECAUTION COULD RESULT IN BODILY INJURY OR DAMAGE TO EQUIPMENT.**

For AutoMate systems, use the APX Point Monitor Rail function to test the module. You can test the Analog Rail module output channels by writing a value between 0 and 4095 to those channels and, with an ammeter, verifying that the output on the terminal points (4-20mA) is proportional.

For DCS 5000, AutoMax, or Distributed Power D-C Drive systems, use the DCS 5000 or AutoMax Programming Executive software I/O Monitor function, respectively. Test output channels by writing a value between 0 and 4095 to those channels and using an ammeter to verify that the signal on the terminal points (4-20mA) is proportional.



## 4.0 PROGRAMMING

This section describes how the data is organized in the module and provides examples of how the module is accessed by application programs.

When creating application programs, the programmer must estimate the magnitude of output data because it must be in the specified range of the Analog Rail module (0-4095).

Recall that at a digital output = 4096, the output rolls over to zero again. The programmer must include limits in the application software to ensure that the data sent to output channels is always in the allowable range.

### 4.1 Analog Rail Module in AutoMate Systems

This section describes how the Analog Rail is used with AutoMate systems. Local Head mode allows all four channels on the module to be updated at the end of the scan (normal I/O update rate in this configuration), or during the scan using AOUT blocks (see section 4.1.4). Rail mode allows only one channel to be updated at the end of the scan (normal I/O update rate in this configuration), or all four channels to be updated during the scan if AOUT blocks are used.

#### 4.1.1 Configuring the AutoMate Processor for Use with the Analog Rail Module

Configuration is the process of describing in software how the hardware and software in the system are related. The Analog Rail module is configured using the AutoMate Programming Executive (APX) software, M/N 45C130 or 45C131. Select CONFIGURE SYSTEM from the main menu to create the configuration.

Note that the Analog Rail module can also be configured using the AutoMate Programming System (APS) software, M/N 45C134, 45C141, 45C142, or 45C143. Refer to instruction manual J2-3041 for additional information.

The Analog Rail module is configured depending upon the mode in which it is being used. See figures 4.1, 4.2, 4.3, 4.4, and 4.5 for how to configure the Analog Rail for use with AutoMate processors. The sample configurations are shown as they appear on the APX screen. Unless otherwise noted, all references to the AutoMate 20, 30, and 40 will also apply to the 20E, 30E and the 40E, respectively.

Analog Rail Module with AutoMate 20  
(Local Head Mode or Rail Mode)

AutoMate 20 registers reserved for port configuration:

2734	Port 0 of AutoMate 20
2735	Port 1 of AutoMate 20
2736	Port 2 of AutoMate 20
2737	Port 3 of AutoMate 20

Local Head Mode

Enter the value 64XX for the register representing the port to which the Analog Rail module is connected, where XX is a value from 00-14\*. The XX value represents the first register in a set of four contiguous registers that will be used to store data for the port.

Rail Mode

Enter the value 16XX for the register representing the port to which the Analog Rail module is connected, where XX is a value from 00-17\*. The XX value represents the register that will be used to multiplex data through the I/O port.

\*Values are in octal notation.

Figure 4.1 - Configuration for Analog Rail Module with AutoMate 20



Analog Rail Module Connected Directly to AutoMate 30 or 40  
(Local Head Mode or Rail Mode)

The following sample configuration shows two Analog Rail modules connected directly to an AutoMate 30 or 40 Processor in Local Head mode:

MSLT	DROP	TYP	RSLT	CARD	CH0	REGISTER	CH1	REGISTER	CH2	REGISTER	CH3	REGISTER
1				A/M	LHD	0-3	LHD	4-7	NU		NU	

The following sample configuration shows two Analog Rail modules connected directly to an AutoMate 30 or 40 Processor in Rail Mode :

MSLT	DROP	TYP	RSLT	CARD	CH0	REGISTER	CH1	REGISTER	CH2	REGISTER	CH3	REGISTER
1				A/M	RAIL	0	RAIL	1	NU		NU	

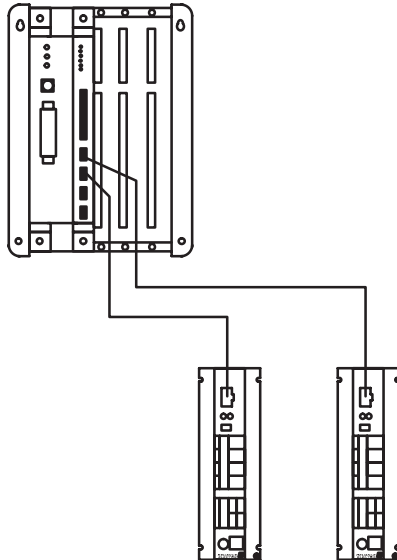

Figure 4.2- Sample Configurations for Analog Rail Module  
Connected Directly to AutoMate 30 or 40

Analog Rail Module Connected to AutoMate 30 or 40 Through a Local I/O Head  
(Rail Mode Only)

The following sample configuration shows two Analog Rail modules connected to an AutoMate 30 or 40 through a Local I/O Head:

MSLT	DROP	TYP	RSLT	CARD	CH0	REGISTER	CH1	REGISTER	CH2	REGISTER	CH3	REGISTER
2				A/M	LHD	0-3	NU		NU		NU	

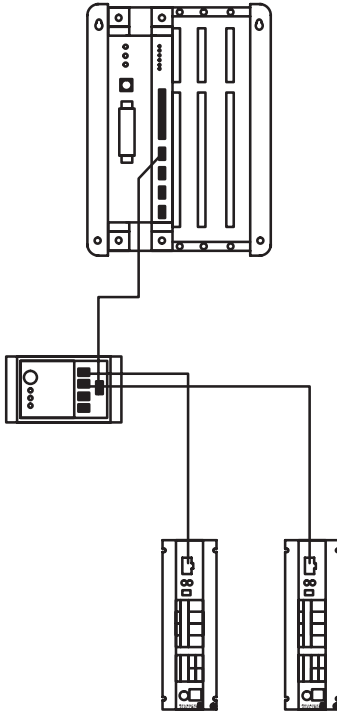

Figure 4.3- Sample Configuration for Analog Rail Module Connected to AutoMate 30 or 40 Through Local I/O Head

Analog Rail Module with AutoMate Local I/O Processor (Local Head Mode Only)

The following sample configuration shows three Analog Rail modules connected to a Local I/O Processor in a remote rack:

MSLT	DROP	TYP	RSLT	CARD	CH0	REGISTER	CH1	REGISTER	CH2	REGISTER	CH3	REGISTER
2	1	RRK	2	LIOP	LHD	0-3	LHD	4-7	LHD	10-13	NU	

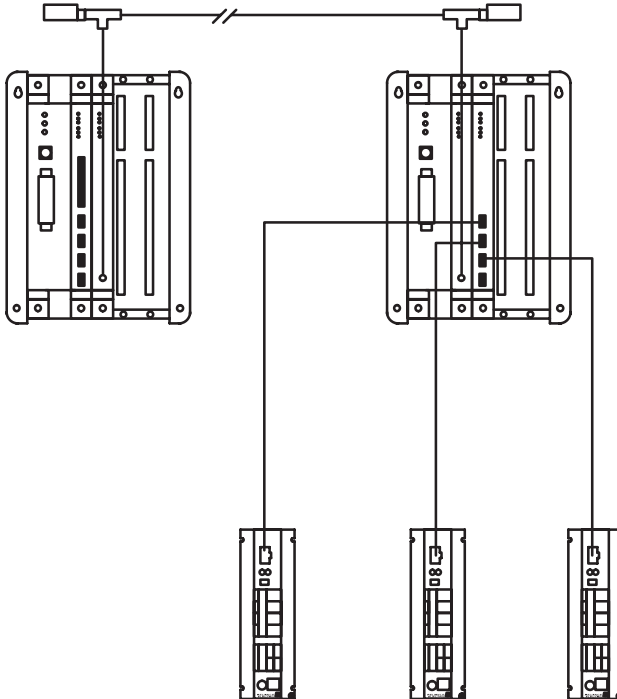

Figure 4.4 - Sample Configuration for Analog Rail Module with AutoMate Local I/O Processor

Analog Rail Module with AutoMate Remote I/O Head (Local Head Mode Only)

The following sample configuration shows one Analog Rail module connected to an AutoMate Remote I/O Head:

MSLT	DROP	TYP	RSLT	CARD	CH0	REGISTER	CH1	REGISTER	CH2	REGISTER	CH3	REGISTER
1	0	RHD			LHD	0-3	NU		NU		NU	

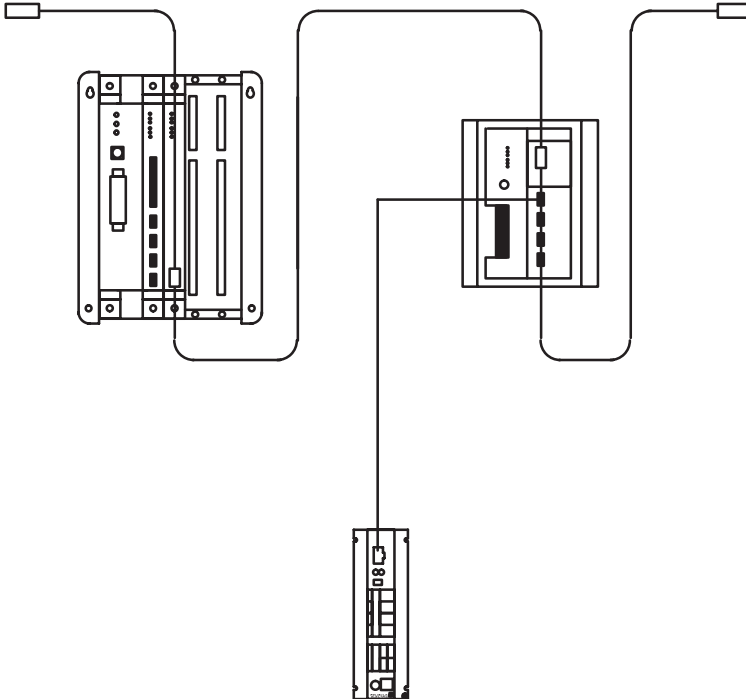

Figure 4.5- Sample Configuration for Analog Rail Module with AutoMate Remote I/O Head

## 4.1.2 AutoMate Programming in Rail Mode

In Rail mode, the Analog Rail module is imaged in one I/O register of the processor. Data from one of the four channels will occupy the register as a function of the channel select bits. The active channel is updated at the end of each scan. For the output channels, the data in the register must be in the format shown in figure 4.6 prior to the I/O update.

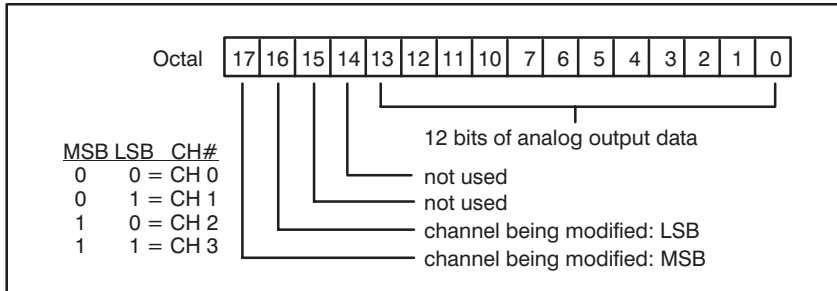

Figure 4.6 - Rail Mode Register Image for Output Channels

The Analog Rail module data may also be accessed in the middle of the scan (as opposed to the end of the scan, which is the normal mode of operation for digital rail I/O) using the appropriate number of Analog Out (AOUT) blocks. The AOUT block will set the channel select bits appropriately. See section 4.1.4 for more information about the AOUT block.

Note that the AOUT block is supported for the AutoMate 20E M/N 45C224 and 45C225, but not the AutoMate 20 (M/N 45C20, 45C21, 45C220, 45C221) by APX Version 3.0.

For processors that do not support the AOUT block, you can use the MOVE block to move data in and out of the registers assigned and to determine the channel select bits. The I/O update will occur automatically at the end of each scan. See Appendix C for a sample AutoMate program that writes to the Analog Rail module without using AOUT blocks.

### 4.1.3 AutoMate Programming in Local Head Mode

In Local Head mode, the module is imaged in four I/O registers of the processor. Data from all four channels is always available and will be updated at the end of each scan. For the output channels, the data in the register must be in the format shown in figure 4.7 prior to the I/O update.

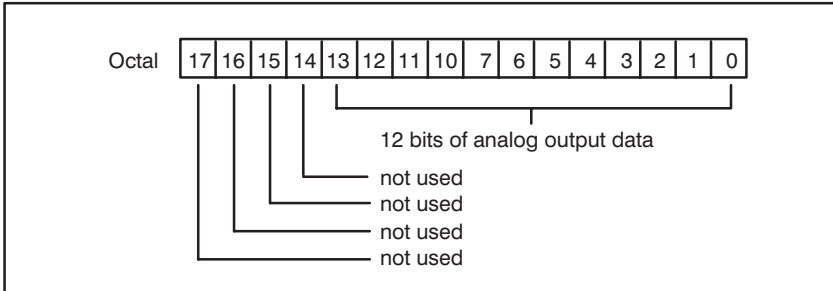

Figure 4.7 - Local Head Register Image for Output Channels

The Analog Rail module data may also be accessed in the middle of the scan (as opposed to the end of the scan) using the appropriate number of Analog Out (AOUT) blocks. See section 4.1.4 for more information about the AOUT block.

Note that the AOUT block is supported for the AutoMate 20E (M/N 45C224 and 45C225), but not the AutoMate 20 (M/N 45C20, 45C21, 45C220, 45C221) by APX Version 3.0.

For processors that do not support the AOUT block, you can use the MOVE block to move data in and out of the registers assigned. The I/O update will occur automatically at the end of each scan. See Appendix C for a sample AutoMate program that writes to the Analog Rail module without using AOUT block.

### 4.1.4 Analog Out (AOUT) Instruction Block

The AOUT block is used to write outputs to the Analog Rail module. AOUT blocks are supported for the 20E processor. The AOUT block makes it possible to update the channels on the Analog Rail module during the scan instead of at the end of the scan (the standard AutoMate I/O update). The block also makes it possible to update all four channels during the scan in Rail mode, a hardware configuration which would otherwise allow only one channel on the module to be updated. The format of the block is shown in figure 4.8.

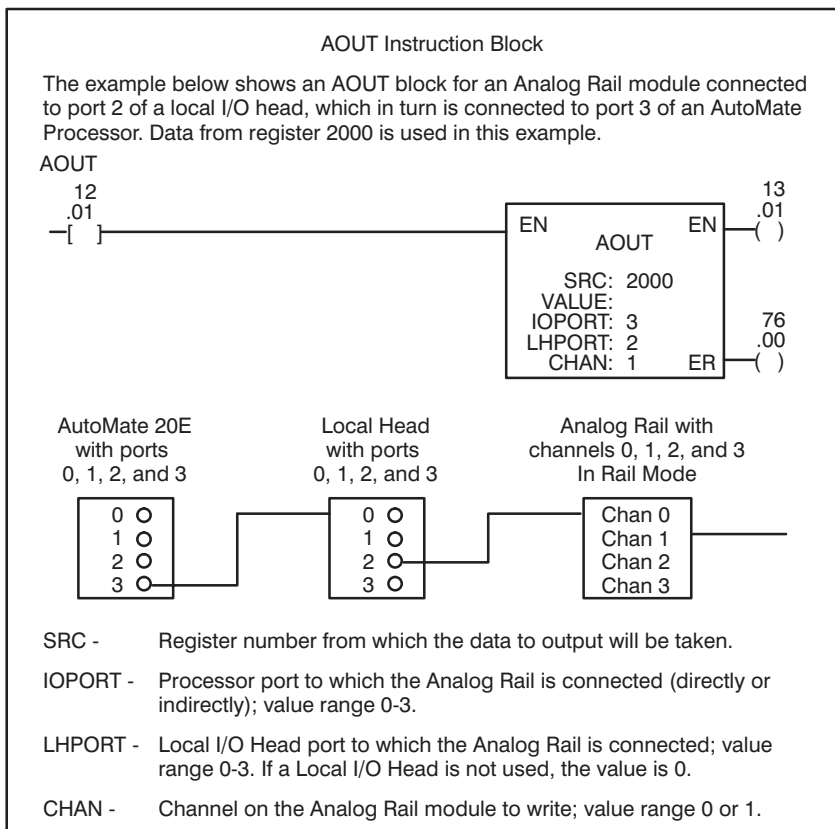

Figure 4.8 - AOUT Instruction Block

## 4.2 Analog Rail Module in DCS 5000/AutoMax Systems

This section describes how the Analog Rail is used with DCS 5000/AutoMax systems.

### 4.2.1 Configuring the Analog Rail Module with a DCS 5000/AutoMax Remote I/O Head

The Analog Rail module is used in the Local Head mode when the host is a DCS 5000/AutoMax Remote I/O Head. For AutoMax Version 3.0 and later, the Analog Rail module is configured using the AutoMax Programming Executive. Refer to instruction manual J-3750 for more information. For DCS 5000 or AutoMax Version 2.1 or earlier, the module is defined in the configuration task for the master rack using the DCS 5000 or AutoMax Programming Executive software. See instruction manual J-3649 for more information on the configuration task.

For DCS 5000 or AutoMax Version 2.1 or earlier, use the RIODEF statement to define each channel on the Analog Rail module as a separate register. Use the following format for the RIODEF statement:

```
nnnnn RIODEF name[MASTER_SLOT=m, DROP=d, SLOT=s, REGISTER=r, BIT=b]
```

where:

- nnnnn - Configuration task line number; range 1-32767.
- name - Symbolic name of channel, ending with % (integer) for registers, @ (booleans) for bits.
- m - Slot in rack containing DCS 5000/AutoMax master remote I/O module; range 0-15.
- d - Drop number of DCS 5000/AutoMax Remote I/O Head; range 1-7.
- s - Communication port on the DCS 5000/AutoMax Remote I/O Head to which the Analog Rail module is connected; range 0-3.
- r - Register number; range 0-3.
- b - Optional field defining the bit position within the register number; range 0-15.

## 4.2.2 Configuring the Analog Rail Module with a Power Module Interface Processor Host

The Analog Rail module is used in the Rail mode when the host is a Power Module Interface (PMI) Processor. Beginning with AutoMax Version 3.3, the Analog Rail module is configured using the AutoMax Programming Executive. Refer to instruction manual J2-3045 for more information.



# 5.0 DIAGNOSTICS AND TROUBLESHOOTING

## DANGER

THE REMAINING STEPS ARE MADE WITH POWER ON. EXERCISE EXTREME CAUTION BECAUSE HAZARDOUS VOLTAGE EXISTS. FAILURE TO OBSERVE THIS PRECAUTION COULD RESULT IN SEVERE BODILY INJURY OR LOSS OF LIFE.

## WARNING

ONLY QUALIFIED ELECTRICAL PERSONNEL FAMILIAR WITH THE CONSTRUCTION AND OPERATION OF THIS EQUIPMENT AND THE HAZARDS INVOLVED SHOULD INSTALL, ADJUST, OPERATE, AND/OR SERVICE THIS EQUIPMENT. READ AND UNDERSTAND THIS MANUAL IN ITS ENTIRETY BEFORE PROCEEDING. FAILURE TO OBSERVE THIS PRECAUTION COULD RESULT IN BODILY INJURY.

## WARNING

INSERTING OR REMOVING THIS PRODUCT OR ITS CONNECTING CABLES MAY RESULT IN UNEXPECTED MACHINE MOTION. POWER TO THE MACHINE SHOULD BE TURNED OFF BEFORE INSERTING OR REMOVING THE PRODUCT OR ITS CONNECTING CABLES. FAILURE TO OBSERVE THIS PRECAUTION COULD RESULT IN BODILY INJURY.

This section explains how to troubleshoot the Analog Rail module. If you cannot correct the problem using the instructions below, the unit is not user-serviceable.

## 5.1 Both LEDs on the Faceplate are Off

Problem: The "PWR OK" and "COM OK" LEDs on the faceplate are off. This problem can indicate that the unit is not receiving the +5V from the processor or Local or Remote Head, the 120 VAC or 24 VDC from the external power supply, or both within the specified ranges. This problem can also indicate that the external power supply fuse (.75A or .25A) has blown or that the module is malfunctioning.

- Step 1. Stop any application programs or tasks that are running. Use a voltmeter to measure the input power (120 VAC or 24 VDC) to the module. Verify that the power source is providing 120 VAC or 24 VDC, whichever is appropriate.

## DANGER

VOLTAGE IS PRESENT ON THE PLUG CONNECTOR TERMINALS. DISCONNECT THE POWER AT THE SOURCE BEFORE TOUCHING THE PLUG CONNECTOR TERMINALS. FAILURE TO OBSERVE THIS PRECAUTION COULD RESULT IN SEVERE BODILY INJURY OR LOSS OF LIFE.

### **DANGER**

**DO NOT TOUCH THE CONNECTORS ON THE FACEPLATE IF THERE IS POWER ON THE WIRES ATTACHED TO THE PLUG CONNECTOR SCREW TERMINALS. ALWAYS TURN OFF POWER BEFORE HANDLING A CONNECTOR THAT IS WIRED. FAILURE TO OBSERVE THIS PRECAUTION COULD RESULT IN SEVERE BODILY INJURY OR LOSS OF LIFE.**

- Step 2. Turn off power to the module. Verify that the input power connector is connected securely to the faceplate. Verify that the I/O Rail cable connections are tight at both ends.
- Step 3. Turn on power to the module. If LEDs are still off, try replacing the I/O Rail cable. Check that the pins on the input connector are not bent.
- Step 4. If the LEDs are still off, turn off power to the module and replace the power supply fuse on the front panel following the directions below.

### **CAUTION**

**MAKE CERTAIN THAT THE ANALOG RAIL MODULE CONTAINS THE PROPER FUSE FOR THE POWER SUPPLY BEING USED. USE A .25 A FUSE FOR 120 VAC POWER AND A .75A FUSE FOR 24 VDC POWER. FAILURE TO OBSERVE THIS PRECAUTION COULD RESULT IN DAMAGE TO OR DESTRUCTION OF THE EQUIPMENT.**

- a) Use a screwdriver to release the fuse holder located on the Analog Rail module faceplate. Pull the fuse holder out of the module.
  - b) Take the old fuse out of the fuse holder and replace it with the new fuse. Use a .25A fuse for 120 VAC power and a .75A fuse for 24 VDC power. See Appendix A for the fuse type and rating.
  - c) Re-insert the fuse holder into the module. Turn the screwdriver clockwise while pressing down on the fuse holder. The fuse holder must be flush against the faceplate.
- Step 5. Turn on power to the module. If both LEDs still do not light, replace the module.

## 5.2 The “COM OK” LED is Off

Problem: The “COM OK” LED on the faceplate is off. This LED signifies whether there is communication between the Analog Rail and the host. The LED should be on if communication is taking place. The possible causes of this problem are incorrect configuration, a disconnected or malfunctioning I/O Rail cable, a malfunctioning host, or a malfunctioning Analog Rail module. After verifying that the configuration of the Analog Rail is correct, follow the steps below to isolate the problem.

- Step 1. Stop any application tasks or programs that are running and turn off power to the Analog Rail module.

### **DANGER**

**VOLTAGE IS PRESENT ON THE PLUG CONNECTOR TERMINALS. DISCONNECT THE POWER AT THE SOURCE BEFORE TOUCHING THE PLUG CONNECTOR TERMINALS. FAILURE TO OBSERVE THIS PRECAUTION COULD RESULT IN SEVERE BODILY INJURY OR LOSS OF LIFE.**

### **DANGER**

**DO NOT TOUCH THE CONNECTORS ON THE FACEPLATE IF THERE IS POWER ON THE WIRES ATTACHED TO THE PLUG CONNECTOR SCREW TERMINALS. ALWAYS TURN OFF POWER BEFORE HANDLING A CONNECTOR THAT IS WIRED. FAILURE TO OBSERVE THIS PRECAUTION COULD RESULT IN SEVERE BODILY INJURY OR LOSS OF LIFE.**

- Step 2. Verify that the connections on both ends of the I/O Rail cable are tight. Check that the pins on the input connector are not bent.
- Step 3. Turn on power to the module. The “COM OK” LED should be illuminated if communication is taking place. If the LED still does not illuminate, turn off power to the module and replace the I/O Rail cable.
- Step 4. If applicable, try to reset the condition by disconnecting and then re-connecting the cable between the host and the Local I/O Head, the AutoMate Remote I/O Head, or the DCS 5000/AutoMax Remote I/O Head. Troubleshoot the host if necessary. If the problem is still not corrected, replace the Analog Rail module.

## 5.3 Incorrect Data

Problem: The data (signal) being written is always on, always off, or different than expected. The possible causes of this problem are incorrect configuration, a programming error, a disconnected or malfunctioning I/O Rail cable, disconnected or malfunctioning wiring to the external hardware, malfunctioning external hardware or a malfunctioning Analog Rail module. After verifying that the configuration of the module is correct, follow the steps below to isolate the problem.

- Step 1. Verify that the application program(s) is correct. Check to see that the program is referencing the correct registers (AutoMate) or symbolic names (DCS 5000/AutoMax). Verify that the data being output is within the specified limits.
- Step 2. Stop any application tasks that are running. Turn off power to the Analog Rail module.
- Step 3. Try to clear the condition by disconnecting and then reconnecting the I/O Rail cable. Make certain the connections are tight. If applicable, check the connections between the host and the Local I/O Head, the AutoMate Remote I/O Head, or the DCS 5000/AutoMax Remote I/O Head. Check that the pins on the input connector are not bent.
- Step 4. Turn off power to the external hardware. Verify that the wiring to the external hardware is tight and functioning correctly.
- Step 5. Turn on power to the external hardware. Before testing, make certain that the external hardware cannot respond to outputs from the Analog Rail module.  
  
For output channels, use the Executive software to write a value between 0 and 4095 to each channel. Use an ammeter to verify that the signal on the terminal points is proportional to the value. If the signal is being converted correctly, there is a problem with the external hardware or wiring.
- Step 6. Troubleshoot the external hardware, the wiring, and the host.

# Appendix A

## Technical Specifications

### Ambient Conditions

- Storage temperature:  $-40^{\circ}\text{C}$  to  $85^{\circ}\text{C}$   
 $-40^{\circ}\text{F}$  to  $185^{\circ}\text{F}$
- Operating temperature (at the module):  $0^{\circ}\text{C}$  to  $60^{\circ}\text{C}$   
 $32^{\circ}\text{F}$  to  $140^{\circ}\text{F}$
- Humidity: 5-90% non-condensing

### Dimensions

- Height: 9.25 inches (23.5 cm)
- Width: 2.94 inches (7.5 cm)
- Depth: 7.75 inches (19.7 cm including plug-in terminals)
- Weight: 4.5 lbs (2.1 kg)

### Recommended Cable for Analog Signal Wiring

- Belden 8761 or equivalent type

### Maximum Power Dissipation

- 4.5 Watts

### Communication Power Requirements

- +5V: 250 mA (supplied by host through I/O Rail cable)

### Analog Circuit Power Supply

(use either 120 VAC or 24 VDC supply)

- 120 VAC supply: 92 - 132V acceptable range (+15% / -20%)  
Maximum current: 150mA
- 24 VDC supply: 20 - 32V acceptable range (+33% / -16%)  
Maximum current: 350mA

### Maximum Source KVA

- 10

### Fuse Types and Rating

- MDQ 250 VAC .25A (for 120 VAC power)
- MDQ 250 VAC .75A (for 24 VDC power)

# Appendix A

## (Continued)

### Output Channels

- Operating range: 4-20mA (short-circuit protected)
- Number of channels: 4 (single-ended)
- Number of commons: 1 (shared among all 4 channels)
- Output range of external power supply channels: 5-32 VDC
- Resolution: 12 bits binary
- Non-linearity:  $\pm 1$  LSB maximum
- Accuracy:  $\pm 0.33\%$  of full scale at 25°C maximum
- Thermal drift: 50 ppm/degrees C
- Gain error:  $\pm 4$  LSB maximum
- Type of converter: 2-2 dual DACs on a monolithic IC
- Speed of conversion: Scan Dependent
- Output settling time: 200 usec. maximum
- Load resistance range: 0-1450 Ohms
- Isolation of analog section from host and input power: 2500V RMS

# Appendix B

## Block Diagram

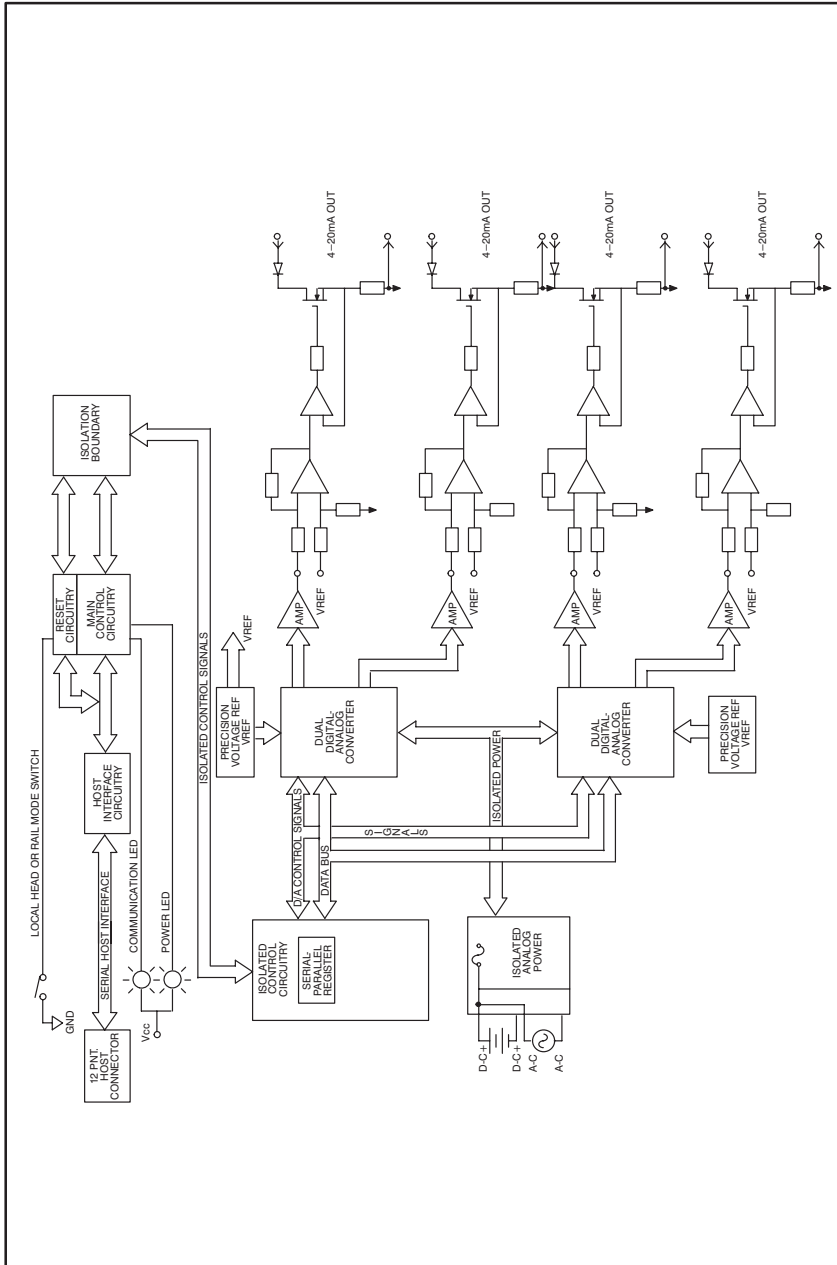





# Appendix C

## Sample AutoMate Program

The following AutoMate program sequences can be used to interface to an AutoMate Processor that does not support the AOUT block. Over a period of four scans, the program below maps registers 40 through 43 to the four channels of an Analog Rail module in Rail mode.

### Registers Used

0	Register that is configured to be updated at the end of scan.
40	Value to output to channel 0
41	Value to output to channel 1
42	Value to output to channel 2
43	Value to output to channel 3
44	Counter to select channel to operate this scan
45	Coils

End of Scan

If counter = 0, then move the data in register 40 to register 0.

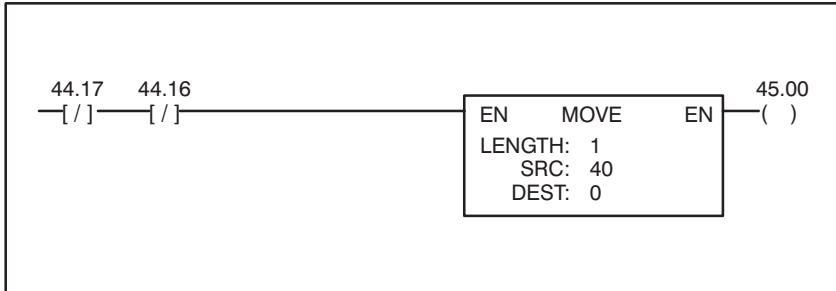

If counter = 1, then move the data in register 41 to register 0.

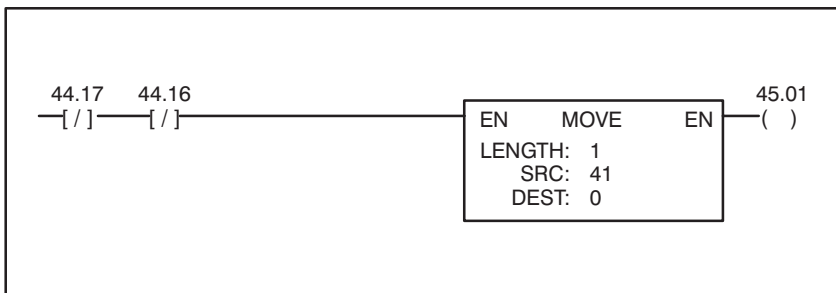

# Appendix C

## (Continued)

If counter = 2, then move the data in register 42 to register 0.

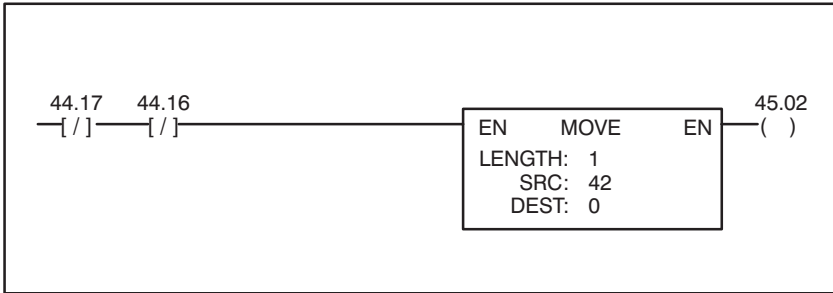

If counter = 3, then move the data in register 43 to register 0.

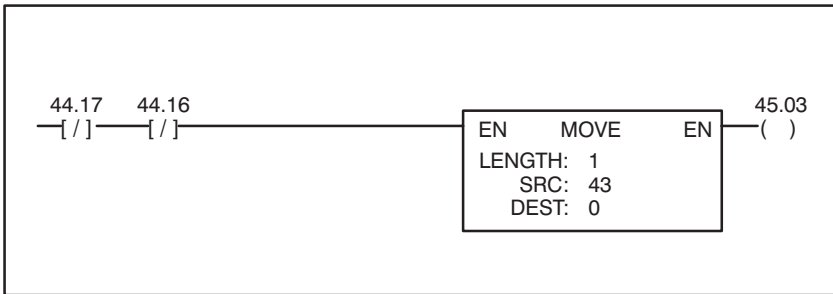

At the End of the Scan

Select which channel to output at end of scan.

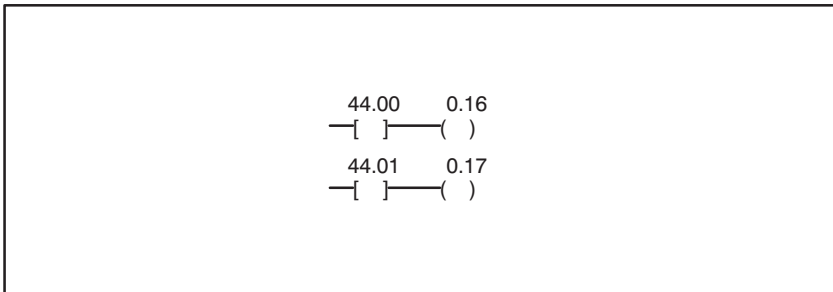

# Appendix C

## (Continued)

Increment counter 0, 1, 2, 3 and then back to 0.

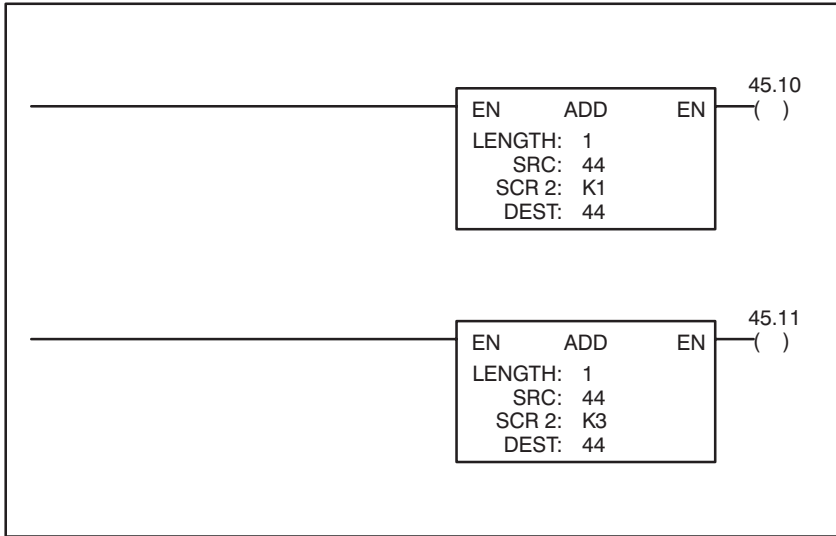





## **For additional information**

1 Allen-Bradley Drive  
Mayfield Heights, Ohio 44124 USA  
Tel: (800) 241-2886 or (440) 646-3599  
<http://www.reliance.com/automax>

[www.rockwellautomation.com](http://www.rockwellautomation.com)

### **Corporate Headquarters**

Rockwell Automation, 777 East Wisconsin Avenue, Suite 1400, Milwaukee, WI, 53202-5302 USA, Tel: (1) 414,212,5200, Fax: (1) 414,212,5201

### **Headquarters for Allen-Bradley Products, Rockwell Software Products and Global Manufacturing Solutions**

Americas: Rockwell Automation, 1201 South Second Street, Milwaukee, WI 53204-2496 USA, Tel: (1) 414,382,2000, Fax: (1) 414,382,4444  
Europe/Middle East/Africa: Rockwell Automation SA/NV, Vorstlaan/Boulevard du Souverain 36, 1170 Brussels, Belgium, Tel: (32) 2 663 0600, Fax: (32) 2 663 0640  
Asia Pacific: Rockwell Automation, 27/F Citicorp Centre, 18 Whitfield Road, Causeway Bay, Hong Kong, Tel: (852) 2887 4788, Fax: (852) 2508 1846

### **Headquarters for Dodge and Reliance Electric Products**

Americas: Rockwell Automation, 6040 Ponders Court, Greenville, SC 29615-4617 USA, Tel: (1) 864,297,4800, Fax: (1) 864,281,2433  
Europe/Middle East/Africa: Rockwell Automation, Brühlstraße 22, D-74834 Eltetal-Dallau, Germany, Tel: (49) 6261 9410, Fax: (49) 6261 17741  
Asia Pacific: Rockwell Automation, 55 Newton Road, #11-01/02 Revenue House, Singapore 307987, Tel: (65) 6356-9077, Fax: (65) 6356-9011