

4 Input 4-20 mA Analog Rail Module

M/N 61C345

Instruction Manual J-3689-2

**RELIANCE
ELECTRIC** 

The information in this user's manual is subject to change without notice.

WARNING

ONLY QUALIFIED ELECTRICAL PERSONNEL WHO ARE FAMILIAR WITH THE CONSTRUCTION AND OPERATION OF THIS EQUIPMENT AND THE HAZARDS INVOLVED SHOULD INSTALL, ADJUST, OPERATE, AND/OR SERVICE THIS EQUIPMENT. READ AND UNDERSTAND THIS MANUAL IN ITS ENTIRETY BEFORE PROCEEDING. FAILURE TO OBSERVE THIS PRECAUTION COULD RESULT IN SEVERE BODILY INJURY.

WARNING

INSERTING OR REMOVING THIS PRODUCT OR ITS CONNECTING CABLES MAY RESULT IN UNEXPECTED MACHINE MOTION. POWER TO THE MACHINE SHOULD BE TURNED OFF BEFORE INSERTING OR REMOVING THE PRODUCT OR ITS CONNECTING CABLES. FAILURE TO OBSERVE THIS PRECAUTION COULD RESULT IN BODILY INJURY.

AutoMax®, AutoMate® and Reliance® are registered trademarks of Reliance Electric Company or its subsidiaries.

Belden® is a registered trademark of Belden, Inc.

Table of Contents

1.0	Introduction	1-1
1.1	Additional Information	1-1
1.2	Related Hardware and Software	1-2
2.0	Mechanical/Electrical Description	2-1
2.1	Mechanical Description	2-1
2.2	Electrical Description	2-3
3.0	Installation	3-1
3.1	Wiring	3-1
3.2	Initial Installation	3-2
3.3	Module Replacement	3-6
4.0	Programming	4-1
4.1	Analog Rail Module in AutoMate Systems	4-1
4.1.1	Configuring the AutoMate Processor for Use with the Analog Rail Module	4-2
4.1.2	AutoMate Programming in Rail Mode	4-7
4.1.3	AutoMate Programming in Local Head Mode	4-7
4.1.4	Analog In (AIN) Instruction Block	4-8
4.2	Analog Rail Module in DCS 5000/AutoMax Systems	4-9
4.2.1	Configuring the Analog Rail Module with a DCS 5000/AutoMax Remote I/O Head	4-9
4.2.2	Configuring the Analog Rail Module with a Power Module Interface Processor Host	4-10
4.2.3	DCS 5000/AutoMax Programming	4-10
5.0	Diagnostics and Troubleshooting	5-1
5.1	Both LEDs on the Faceplate are Off	5-1
5.2	The "COM OK" LED is Off	5-2
5.3	Incorrect Data	5-3
5.4	Constant Under-Range	5-4

Appendices

- Appendix A**
 - Technical Specifications A-1

- Appendix B**
 - Block Diagram B-1

- Appendix C**
 - Sample AutoMate Program C-1

List of Figures

Figure 1.1	- Analog Rail Module Hardware Configuration	1-3
Figure 2.1	- Analog Rail Module Faceplate	2-2
Figure 2.2	- Typical Input Circuit	2-4
Figure 3.1	- Mounting Dimensions	3-2
Figure 3.2	- Typical Recommended Input Shielding Methods	3-5
Figure 4.1	- Input Signal Conversion	4-1
Figure 4.2	- Configuration for Analog Rail Module with AutoMate 20	4-2
Figure 4.3	- Sample Configurations for Analog Rail Module Connected Directly to AutoMate 30 or 40	4-3
Figure 4.4	- Sample Configuration for Analog Rail Module Connected to AutoMate 30 or 40 Through Local I/O Head	4-4
Figure 4.5	- Sample Configuration for Analog Rail Module with AutoMate Local I/O Processor	4-5
Figure 4.6	- Sample Configuration for Analog Rail Module with AutoMate Remote I/O Head	4-6
Figure 4.7	- Rail Mode Register Image for Input Channels	4-7
Figure 4.8	- Local Head Register Image for Input Channels	4-8
Figure 4.9	- AIN Instruction Block	4-9
Figure 5.1	- Disassembling the Module to Replace the 32mA Fuse	5-5
Figure 5.2	- Replacing the 32mA Fuse	5-6

1.0 INTRODUCTION

The products described in this instruction manual are manufactured by Reliance Electric Industrial Company.

The 4 Input 4-20mA Analog Rail module allows you to connect four input 4-20mA analog signals to AutoMate®, AutoMax® and DCS 5000 systems. Typically, the Analog Rail module is used with potentiometers, valve actuators, pressure or flow transducers, and meters in both drive control systems and process control systems.

The Analog Rail module is hardware-configurable by means of a faceplate switch to emulate one of two types of devices, AutoMate Rails or AutoMate Local Heads. In some hardware configurations, the type of interface device available for the Analog Rail module will determine the mode of operation that can be selected (see figure 1.1).

The Analog Rail module operates in Local Head mode when it is connected directly to one of the processor's four I/O ports in AutoMate systems, to an AutoMate Local I/O Processor, or to one of the four I/O ports of the DCS 5000/AutoMax Remote I/O Head in DCS 5000/AutoMax systems. The Analog Rail data will take up four registers in the host when operating in Local Head mode.

The module operates in Rail mode when it is connected to one I/O port of a Local I/O Head, which in turn is connected to one I/O port of an AutoMate processor. The Analog Rail module will occupy one register of the host in Rail mode. The Rail mode is used to expand the I/O address space available through the front I/O port of the processor by multiplexing each group of four analog points through one register. Note that the Analog Rail module cannot be used with the Local I/O Head in DCS 5000/AutoMax systems.

The Analog Rail module operates in Rail mode when it is connected to one I/O port of the Power Module Interface (PMI) Processor (B/M 60000), which is in turn connected to a Universal Drive Controller (UDC) module (M/N 57552) which resides in an AutoMax rack.

The remainder of this manual describes the functions and specifications of the module. It also includes a detailed overview of installation and troubleshooting procedures, as well as examples of configuration and programming.

1.1 Additional Information

You must become familiar with the instruction manuals which describe your system configuration. This may include, but is not limited to, the following:

- J-3031 AutoMate 30 PROCESSOR HARDWARE INSTRUCTION MANUAL
- J-3033 AutoMate LOCAL I/O PROCESSOR INSTRUCTION MANUAL
- J-3037 AutoMate REMOTE I/O HEAD INSTRUCTION MANUAL
- J-3063 AutoMate PROGRAMMING EXECUTIVE INSTRUCTION MANUAL
- J-3120 AutoMate 20 USER'S MANUAL

- J-3141 AutoMate 40 CONTROL PROCESSOR INSTRUCTION MANUAL
- J-3150 AutoMate 30/40 SOFTWARE REFERENCE MANUAL
- J-3649 DCS 5000/AutoMax CONFIGURATION TASK INSTRUCTION MANUAL
- J-3630 AutoMax PROGRAMMING EXECUTIVE INSTRUCTION MANUAL
- J-3600 DCS 5000 ENHANCED BASIC LANGUAGE INSTRUCTION MANUAL
- J-3675 AutoMax ENHANCED BASIC LANGUAGE INSTRUCTION MANUAL
- J-3601 DCS 5000 CONTROL BLOCK LANGUAGE INSTRUCTION MANUAL
- J-3676 AutoMax CONTROL BLOCK LANGUAGE INSTRUCTION MANUAL
- J-3602 DCS 5000 CONTROL BLOCK LANGUAGE INSTRUCTION MANUAL
- J-3677 AutoMax LADDER LOGIC LANGUAGE INSTRUCTION MANUAL
- J-3671 AutoMate LOCAL I/O HEAD INSTRUCTION MANUAL
- J-3750 ReSource AutoMax PROGRAMMING EXECUTIVE INSTRUCTION MANUAL, VERSION 3.0
- J2-3045 AutoMax PROGRAMMING EXECUTIVE VERSION 3.3
- S-3006 D-C DRIVE CONFIGURATION AND PROGRAMMING INSTRUCTION MANUAL
- S-3008 POWER MODULE INTERFACE RACK INSTRUCTION MANUAL
- Your personal computer and DOS operating system manual(s).
- IEEE 518 GUIDE FOR THE INSTALLATION OF ELECTRICAL EQUIPMENT TO MINIMIZE ELECTRICAL NOISE INPUTS TO CONTROLLERS

1.2 Related Hardware and Software

The 4 Input 4-20mA Analog Rail module, M/N 61C345, contains the following:

1. One 4 Input 4-20mA Analog Rail module
2. One I/O Rail cable: M/N 45C5
3. Two plug connectors: 12-point connector part no. 419434-2R
4-point connector part no. 419434-1R
4. One .25A fuse (installed in the module): part no. 64676-23J
5. One .75A fuse (required for operation on 24 VDC):
part no. 64676-23Q

6. Two cable retainer clips
7. Four 32mA fuses (installed in the module): part no. 64676-44A
8. Four spare 32mA fuses: part no. 64676-44A

The Analog Rail module can be configured with the hardware (purchased separately) listed in figure 1.1.

Host	Model	Operating Mode
DCS 5000/AutoMax Remote I/O Head	M/N 57C330	Local Head
AutoMate 20, 20E	M/N 45C20, 45C21, 45C220, 45C221, 45C224, 45C225	Local Head or Rail *
AutoMate 30, 30E	M/N 45C301, 45C305, 45C307	Local Head or Rail *
AutoMate 40, 40E	M/N 45C410, 45C411	Local Head or Rail *
AutoMate Local I/O Processor	M/N 45C200B (and later versions)	Local Head
AutoMate Remote I/O Head	M/N 45C37, 45C38	Local Head
Power Module Interface Processor	B/M 60000	Rail
* Direct connection to the Processors (Local Head mode) or connection through an AutoMate Local I/O Head, M/N 45C22, 61C22, 61C22A, or 61C23 (Rail mode). Note that it is also permissible to configure the Analog Rail module for Rail mode even if it is connected directly to an AutoMate 20, 30, or 40 Processor.		

Figure 1.1 - Analog Rail Module Hardware Configuration

2.0 MECHANICAL/ELECTRICAL DESCRIPTION

The following sections describe the mechanical and electrical characteristics of the Analog Rail module.

2.1 Mechanical Description

The Analog Rail module is a self-contained electronic module containing four analog channels that are multiplexed to an analog-to-digital converter. The module is housed in a protective metal enclosure designed for panel mounting. See figure 2.1.

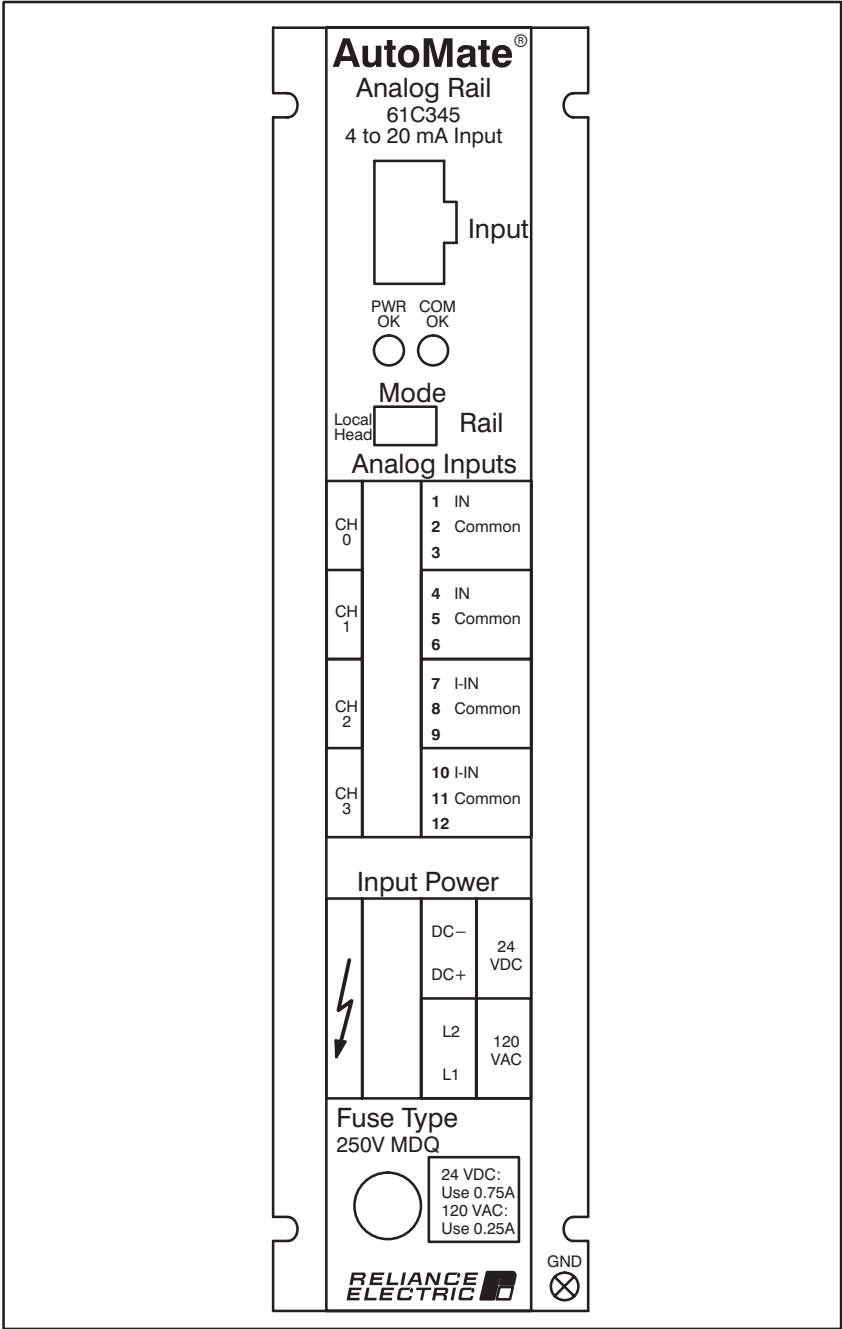

Figure 2.1 - Analog Rail Module Faceplate

The faceplate of the module contains three electrical connectors labeled "Input", "Analog I/O", and "Input Power" (reading top to bottom). The top connector is used for connection to the I/O port. A cable (M/N 45C5) is provided for this purpose. The second connector, labeled "Analog I/O", is a numbered, 12-point removable plug connector with screw-type terminal points. Three successive terminal points are reserved for each channel's connection to external hardware. The "Analog Inputs" terminals are designed for 14-22 AWG wire.

The third connector on the faceplate, also a removable plug connector with screw-type terminal points, is used for input power. The terminal points are labeled. The top two points are used if the power source is 24 VDC. The bottom two points are used if the power source is 120 VAC. The "Input Power" terminals are designed to use 14 AWG wire. A terminal stud for connecting a grounding conductor is provided on the bottom of the right-hand mounting flange.

The module faceplate also contains two LEDs, a mode switch, and a fuse holder and fuse. The LED labeled "PWR OK" indicates that the I/O port, the external power source, and the internally-generated voltages necessary for operation of the module are present. The "COM OK" LED indicates whether all four channels are successfully communicating with the host.

The switch labeled "Mode" is used to select between "Local Head" and "Rail" mode. Note that the position of the switch is read only once at the time power is turned on to the Reliance device that is connected to the Analog Rail module. The mode will remain fixed as long as this device is powered up.

As shipped from the factory, the fuse holder on the bottom of the faceplate contains a .25A fuse for 120 VAC input power. If input power will be 24 VDC, you need to replace the fuse with the .75A fuse included along with the Analog Rail module.

2.2 Electrical Description

The Analog Rail module contains four analog input channels that convert 4-20mA analog input signals to proportional values between 0 and 4095, equal to 12 bits of digital data. Input channels are protected with a 32mA user-replaceable fuse. Input signals are filtered through a second order low-pass filter.

The A/D conversion is triggered by the actual I/O update sequences. The conversion rate is therefore dependent upon the scan time of the application task. See figure 2.2 for a typical input circuit.

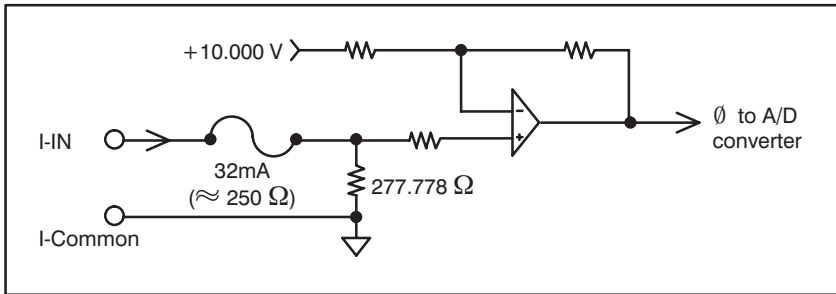

Figure 2.2 - Typical Input Circuit

The Analog Rail module is factory calibrated and requires no offset/gain adjustment. All four analog input channels are referenced to the same common. This common is isolated from both the external power supply and the I/O port connection.

The module incorporates extensive diagnostics. In Rail mode, check bits are monitored for accuracy on every transfer of data between the processor and the module. In Local Head mode, parity bits are monitored for accuracy on every transfer of data. A Rail fault LED on the processor, Remote Head, or Local Head will be illuminated if the check bits or parity bits are wrong and all transmission will stop after n retries, where n is a value determined by the host's software (average $n = 4$ for AutoMax; AutoMate $n = 2$).

In the event of a rail fault, the "COM OK" LED on the module will go off. If any power required by the module, i.e., the +5 Volts from the I/O port required for communication, the external power supply, or the power required by the Analog input section, is not within specified limits, the "PWR OK" LED will go off.

3.0 INSTALLATION

This section describes how to install and replace the Analog Rail module. Note that analog signals are sensitive to variations in temperature. The Analog Rail module is designed to perform optimally at room temperature, approximately 25°C. In all cases, the ambient temperature of the installation must be maintained in the range specified in Appendix A to ensure the highest possible accuracy.

DANGER

THE USER IS RESPONSIBLE FOR CONFORMING WITH THE NATIONAL ELECTRICAL CODE AND ALL OTHER APPLICABLE LOCAL CODES. WIRING PRACTICES, GROUNDING, DISCONNECTS, AND OVER-CURRENT PROTECTION ARE OF PARTICULAR IMPORTANCE. FAILURE TO OBSERVE THIS PRECAUTION COULD RESULT IN SEVERE BODILY INJURY OR LOSS OF LIFE.

DANGER

DO NOT TOUCH THE CONNECTORS ON THE FACEPLATE IF THERE IS POWER ON THE WIRES ATTACHED TO THE PLUG CONNECTOR SCREW TERMINALS. ALWAYS TURN OFF POWER BEFORE HANDLING A CONNECTOR THAT IS WIRED. FAILURE TO OBSERVE THIS PRECAUTION COULD RESULT IN SEVERE BODILY INJURY OR LOSS OF LIFE.

CAUTION

THE ANALOG RAIL MODULE IS DESIGNED TO BE POWERED BY EITHER 24 VDC OR 120 VAC. CONNECT THE PROPER POWER SOURCE TO THE MODULE. FAILURE TO OBSERVE THIS PRECAUTION COULD RESULT IN DAMAGE TO OR DESTRUCTION OF THE EQUIPMENT.

3.1 Wiring

To reduce the possibility of electrical noise interfering with the proper operation of the control system, exercise care when installing the wiring between the module and the external hardware.

Use shielded twisted pair for all wiring between the Analog Rail module and the external hardware. Belden™ 8761 or an equivalent cable type is recommended. For detailed recommendations refer to IEEE 518.

3.2 Initial Installation

Use the following procedure to install the Analog Rail module.

- Step 1. Using the mounting dimensions shown in figure 3.1, prepare the necessary mounting provisions on the panel. The module is designed to be mounted vertically using four #10 or M5 bolts or studs. Multiple modules should be mounted side by side. The flange width of two modules side by side is sufficient to dissipate the heat produced by the modules. The modules can also be mounted one above the other, but since this hardware configuration does not allow the most efficient heat dissipation, the minimum clearance between the module chassis is 3". See figure 3.1.

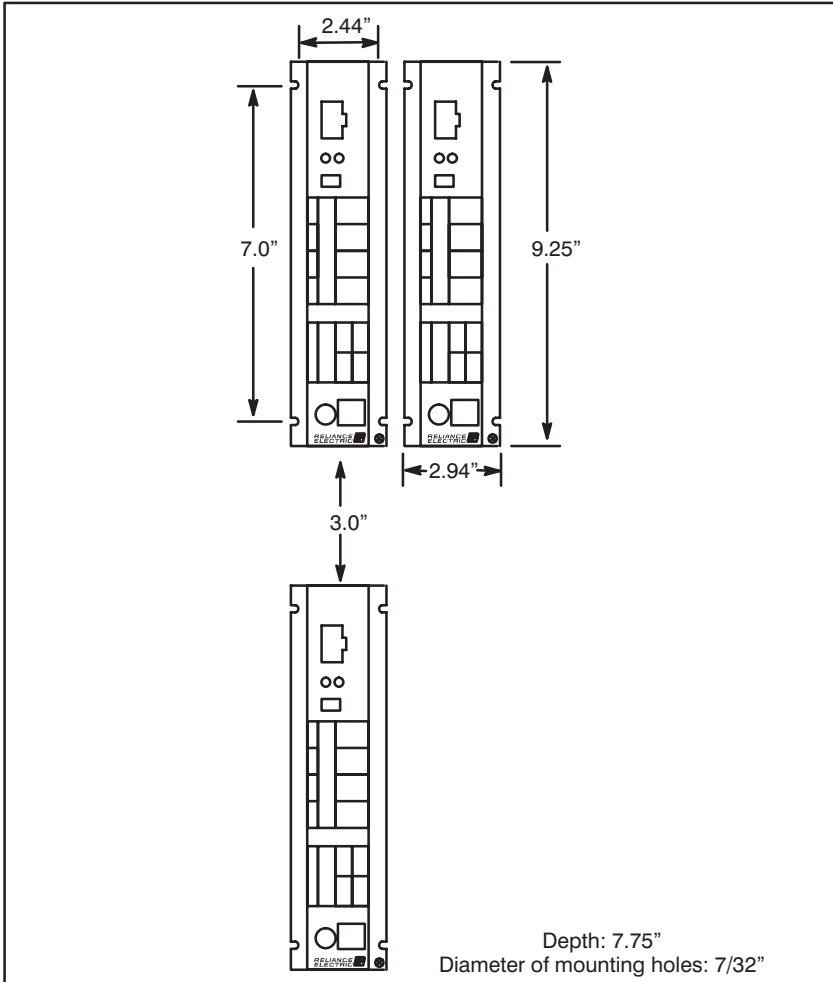

Figure 3.1 - Mounting Dimensions

- Step 2. If the power supply you are using is 24 VDC, replace the factory-installed .25A fuse with the .75A fuse that came in the shipping box with the module. Use a screwdriver to release the fuse holder located on the Analog Rail module faceplate. Pull the fuse holder out of the module. Take the .25A fuse out of the fuse holder and replace it with the .75A fuse. Re-insert the fuse holder into the module. Turn the screwdriver clockwise while pressing down on the fuse holder. The fuse holder must be flush against the faceplate.
- Step 3. Mount the Analog Rail on the panel and attach it securely to the wall with #10 (M5) studs or bolts.
- Step 4. Make certain that no voltage is present on the wires that will be used to provide 120 VAC or 24 VDC power to the Analog Rail module. Use either a 120 VAC or 24 VDC power supply, but not both.
- Step 5. Using 14 AWG wire, connect input power to the screw terminals on the “Input Power” plug connector on the faceplate as shown below. Strip off approximately 5/16” of insulation from the wires.

24 VDC Power

Signal	Terminal Label	Terminal Number
24 VDC –	DC–	1
24 VDC +	DC+	2

120 VAC Power

Signal	Terminal Label	Terminal Number
120 VAC – (neutral)	L2/N	3
120 VAC + (hot)	L1	4

- Step 6. Use the stud marked “GND” (ground) on the bottom right flange of the module to connect a ground wire.

DANGER

THE USER IS RESPONSIBLE FOR CONFORMING WITH THE NATIONAL ELECTRICAL CODE AND ALL OTHER APPLICABLE LOCAL CODES. WIRING PRACTICES, GROUNDING, DISCONNECTS, AND OVER-CURRENT PROTECTION ARE OF PARTICULAR IMPORTANCE. FAILURE TO OBSERVE THIS PRECAUTION COULD RESULT IN SEVERE BODILY INJURY OR LOSS OF LIFE.

- Step 7. Turn off all power to any external hardware that will provide input signals to the module or be powered by the module.
- Step 8. Attach a retainer clip to the connector at each end of the I/O Rail cable (M/N 45C5). Note that faceplate connectors have slots that correspond to the part of the retainer clip that protrudes away from the cable connector. The retainer clip is used to assure a tight connection between the cable and faceplate connectors.
- Step 9. Using 14-22AWG wire, connect external hardware to the “Analog Inputs” plug connector on the faceplate as shown below. Strip off approximately 5/16” insulation from the wires.

Channel	Terminal Number	Terminal Label	Signal
0	1	I-IN	4-20mA+ input common (shield; no connection)*
	2	Common	
	3	(no label)	
1	4	I-IN	4-20mA+ input common (shield; no connection)*
	5	Common	
	6	(no label)	
2	7	I-IN	4-20mA+ input common (shield; no connection)*
	8	Common	
	9	(no label)	
3	10	I-IN	4-20mA+ input common (shield; no connection)*
	11	Common	
	12	(no label)	

*This terminal makes no electrical connection to the Analog Rail printed circuit board.

- Step 10. For each of the four input channels, connect a shield wire from the external hardware to the third terminal (terminals 3, 6, 9 and 12, respectively) on each channel. The shield wire at the external hardware end of the cable should be connected to the source reference point. See figure 3.2.

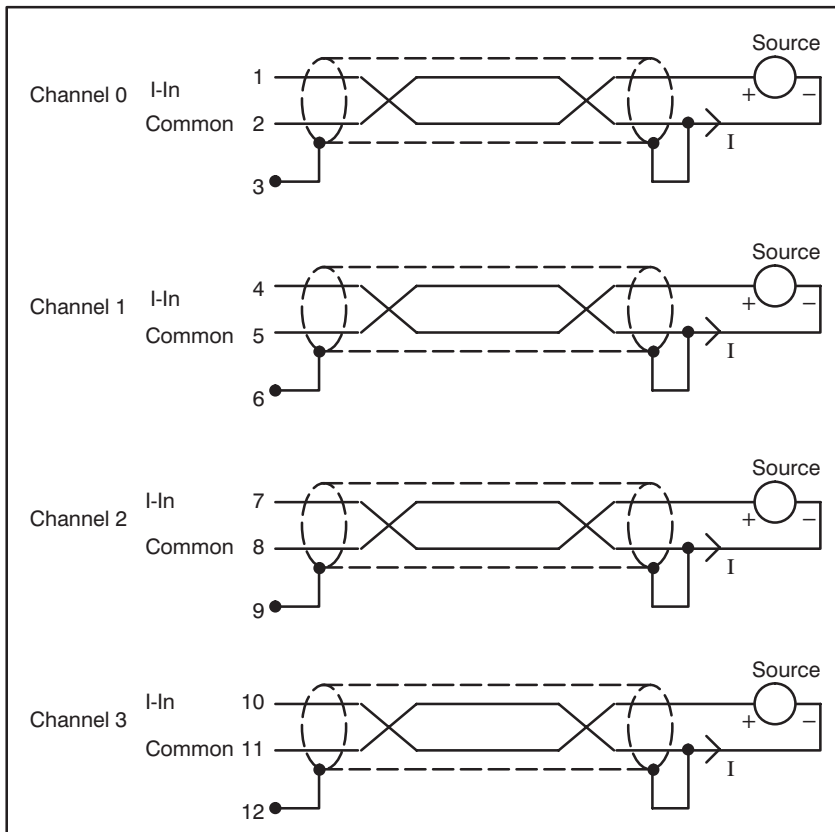

Figure 3.2 - Typical Recommended Input Shielding Methods

- Step 11. Turn off power to the Reliance device that will be connected to the Analog Rail module.
- Step 12. Set the “Mode” switch on the faceplate of the Analog Rail module to the desired position.
- Step 13. Connect the I/O Rail cable between the Analog Rail connection labeled “Input” and an I/O port on the Reliance device that will communicate with the module. Turn on power to the Reliance device that will communicate with the Analog Rail module. Recall that the Mode switch is read each time the Reliance device connected to the module is powered up.
- Step 14. The Analog Rail installation is now ready for testing. Inspect all work to assure that the installation has been performed properly.
- Step 15. Turn on power to the “Input Power” wiring. Turn on power to the external hardware. See Appendix A for the power supply specifications.

- Step 16. Verify that the hardware has been installed correctly.
- For AutoMate systems, you must configure the AutoMate processor using the AutoMate Programming Executive (APX) before testing. See section 4.0 for more information. After configuring the module, use the APX Point Monitor function to test the module. You can test the Analog Rail module input channels by verifying that the input signal in the channel (4-20mA) is proportional to an ammeter reading at the terminal points.
- For DCS 5000, AutoMax, or Distributed Power D-C Drive systems, use the DCS 5000 or AutoMax Programming Executive software I/O Monitor function, respectively. To test the input channels, verify that the input signal in the channel (4-20mA) is proportional to a ammeter reading at the terminal points.

3.3 Module Replacement

Use the following procedure to replace the module.

- Step 1. Stop any application programs that are running.
- Step 2. Turn off power to the external hardware connected to the input channels on the faceplate of the module.
- Step 3. Turn off power to the Analog Rail module (120 VAC or 24 VDC).
- Step 4. Turn off power to the Reliance device connected to the Analog Rail module.
- Step 5. Disconnect the I/O Rail cable from the Analog Rail module.
- Step 6. Without disconnecting the wiring, remove the 12-point terminal from the faceplate and set aside.
- Step 7. Without disconnecting the wiring, remove the 4-point terminal from the faceplate and set aside. Disconnect the ground wire from the bottom of the right-hand flange.
- Step 8. Loosen the screws that hold the Analog Rail module to the panel and remove the module.
- Step 9. If the power supply you are using is 24 VDC, you need to replace the factory-installed .25A fuse in the new module with the .75A fuse that came in the shipping box with the module. Use a screwdriver to release the fuse holder located on the Analog Rail module faceplate. Pull the fuse holder out of the module.
- Remove the .25A fuse from the fuse holder and replace it with the .75A fuse. Re-insert the fuse holder into the module. Turn the screwdriver clockwise while pressing down on the fuse holder at the same time. The fuse holder must be flush against the faceplate.
- Step 10. Remove the two plug connectors from the faceplate of the new module by pulling them firmly away from the faceplate.
- Step 11. Place the new module over the pattern drilled and attach it securely to the panel with #10 or M5 studs or bolts.

- Step 12. Attach the original 12-point and 4-point connectors with wiring to the faceplate of the module. Use the stud marked "GND" (ground) on the bottom right flange of the module to connect a ground wire.
- Step 13. Set the "Mode" switch on the faceplate to the desired position.
- Step 14. Connect the I/O Rail cable between the Analog Rail connection labeled "Input" and any rail connector on the Reliance device that will communicate with the module. Turn on power to the Reliance device connected to the Analog Rail module. Recall that the Mode switch is read each time the Reliance device connected to the module is powered up. If applicable, re-connect the cable between the Local I/O Head, or the DCS 5000/AutoMax Remote I/O Head, and the host.
- Step 15. Turn on power to the Analog Rail module "Input Power" connections.
- Step 16. Turn on power to the external hardware connected to the Analog Rail module.
- Step 17. Verify that the hardware has been installed correctly.
- For AutoMate systems, use the APX Point Monitor function to test the module. To test the input channels, verify that the input signal in the channel (4-20mA) is proportional to an ammeter reading at the terminal points.
- For DCS 5000, AutoMax, or Distributed Power D-C Drive systems, use the DCS 5000 or AutoMax Programming Executive software I/O Monitor function, respectively. To test the input channels, verify that the input signal in the channel (4-20mA) is proportional to an ammeter reading at the terminal points.

4.0 PROGRAMMING

This section describes how the data is organized in the module and provides examples of how the module is accessed by application programs.

When creating application programs, the programmer must estimate the magnitude of input signals because they must be in the specified range of the Analog Rail module (4-20 mA). Input signals greater than 20 mA will be clamped at 4095. Signals greater than approximately 22.1 mA will also cause the over-range bit (12 decimal; 14 octal) to be set to 1. Input signals less than 4 mA are clamped at zero (0). Signals less than approximately 2.4 mA will also cause the under-range bit (13 decimal; 15 octal) to be set to 1. See figure 4.1.

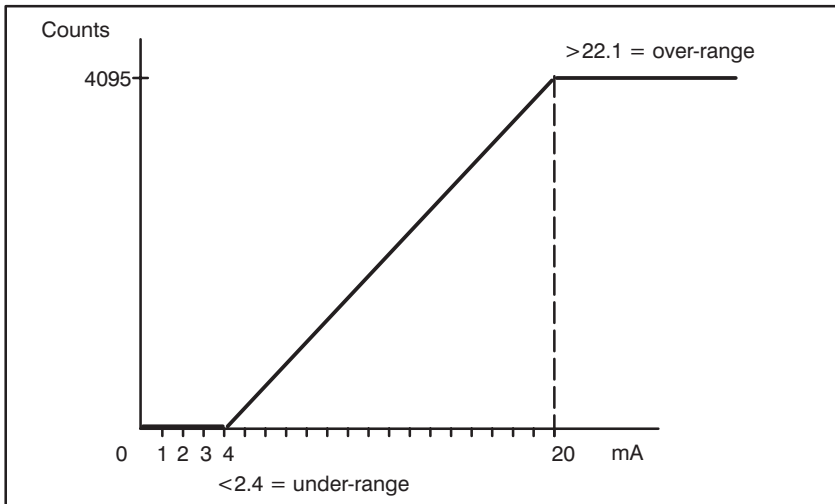

Figure 4.1 - Input Signal Conversion

4.1 Analog Rail Module in AutoMate Systems

This section describes how the Analog Rail is used with AutoMate systems. Local Head mode allows all four channels on the module to be updated at the end of the scan (normal I/O update rate in this configuration), or during the scan using AIN blocks (see section 4.1.4). Rail mode allows only one channel to be updated at the end of the scan (normal I/O update rate in this configuration), or all four channels to be updated during the scan if AIN blocks are used.

4.1.1 Configuring the AutoMate Processor for Use with the Analog Rail Module

Configuration is the process of describing in software how the hardware and software in the system are related. The Analog Rail module is configured using the AutoMate Programming Executive (APX) software, M/N 45C130 or 45C131. Select CONFIGURE SYSTEM from the main menu to create the configuration.

Note that the Analog Rail module can also be configured using the AutoMate Programming System (APS) software, M/N 45C134, 45C141, 45C142, or 45C143. Refer to instruction manual J2-3041 for additional information.

The Analog Rail module is configured depending upon the mode in which it is being used. See figures 4.2, 4.3, 4.4, 4.5, and 4.6 for how to configure the Analog Rail for use with AutoMate processors. The sample configurations are shown as they appear on the APX screen. Unless otherwise noted, all references to the AutoMate 20, 30, and 40 will also apply to the 20E, 30E and the 40E, respectively.

Analog Rail Module with AutoMate 20 (Local Head Mode or Rail Mode)

AutoMate 20 registers reserved for port configuration:

2734	Port 0 of AutoMate 20
2735	Port 1 of AutoMate 20
2736	Port 2 of AutoMate 20
2737	Port 3 of AutoMate 20

Local Head Mode

Enter the value 64XX for the register representing the port to which the Analog Rail module is connected, where XX is a value from 00-14*. The XX value represents the first register in a set of four contiguous registers that will be used to store data for the port.

Rail Mode

Enter the value 16XX for the register representing the port to which the Analog Rail module is connected, where XX is a value from 00-17*. The XX value represents the register that will be used to multiplex data through the I/O port.

*Values are in octal notation.

Figure 4.2 - Configuration for Analog Rail Module with AutoMate 20

Analog Rail Module Connected Directly to AutoMate 30 or 40
(Local Head Mode or Rail Mode)

The following sample configuration shows two Analog Rail modules connected directly to an AutoMate 30 or 40 Processor in Local Head mode:

MSLT	DROP	TYP	RSLT	CARD	CH0	REGISTER	CH1	REGISTER	CH2	REGISTER	CH3	REGISTER
1				A/M	LHD	0-3	LHD	4-7	NU		NU	

The following sample configuration shows two Analog Rail modules connected directly to an AutoMate 30 or 40 Processor in Rail Mode :

MSLT	DROP	TYP	RSLT	CARD	CH0	REGISTER	CH1	REGISTER	CH2	REGISTER	CH3	REGISTER
1				A/M	RAIL	0	RAIL	1	NU		NU	

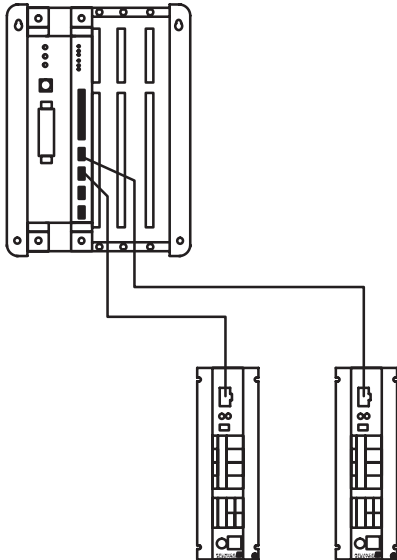

Figure 4.3- Sample Configurations for Analog Rail Module
Connected Directly to AutoMate 30 or 40

Analog Rail Module Connected to AutoMate 30 or 40 Through a Local I/O Head
(Rail Mode Only)

The following sample configuration shows two Analog Rail modules connected to an AutoMate 30 or 40 through a Local I/O Head:

MSLT	DROP	TYP	RSLT	CARD	CH0	REGISTER	CH1	REGISTER	CH2	REGISTER	CH3	REGISTER
2				A/M	LHD	0-3	NU		NU		NU	

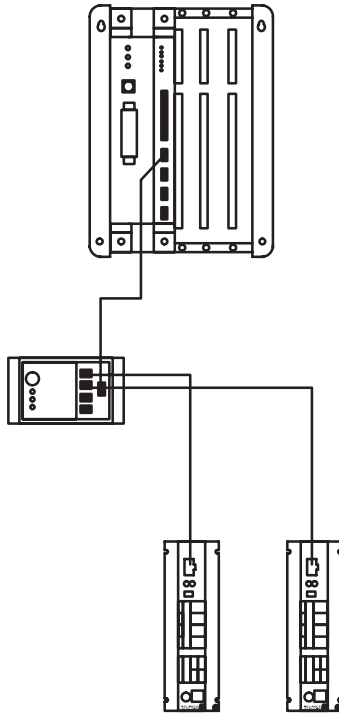

Figure 4.4 - Sample Configuration for Analog Rail Module Connected to AutoMate 30 or 40 Through Local I/O Head

Analog Rail Module with AutoMate Local I/O Processor (Local Head Mode Only)

The following sample configuration shows three Analog Rail modules connected to a Local I/O Processor in a remote rack:

MSLT	DROP	TYP	RSLT	CARD	CH0	REGISTER	CH1	REGISTER	CH2	REGISTER	CH3	REGISTER
2	1	RRK	2	LIOP	LHD	0-3	LHD	4-7	LHD	10-13	NU	

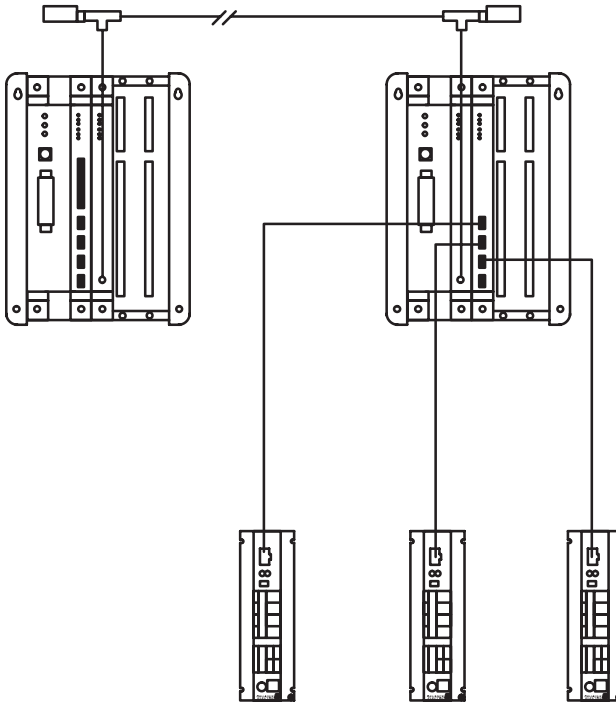

Figure 4.5- Sample Configuration for Analog Rail Module with AutoMate Local I/O Processor

Analog Rail Module with AutoMate Remote I/O Head (Local Head Mode Only)

The following sample configuration shows one Analog Rail module connected to an AutoMate Remote I/O Head:

MSLT	DROP	TYP	RSLT	CARD	CH0	REGISTER	CH1	REGISTER	CH2	REGISTER	CH3	REGISTER
1	0	RHD			LHD	0-3	NU		NU		NU	

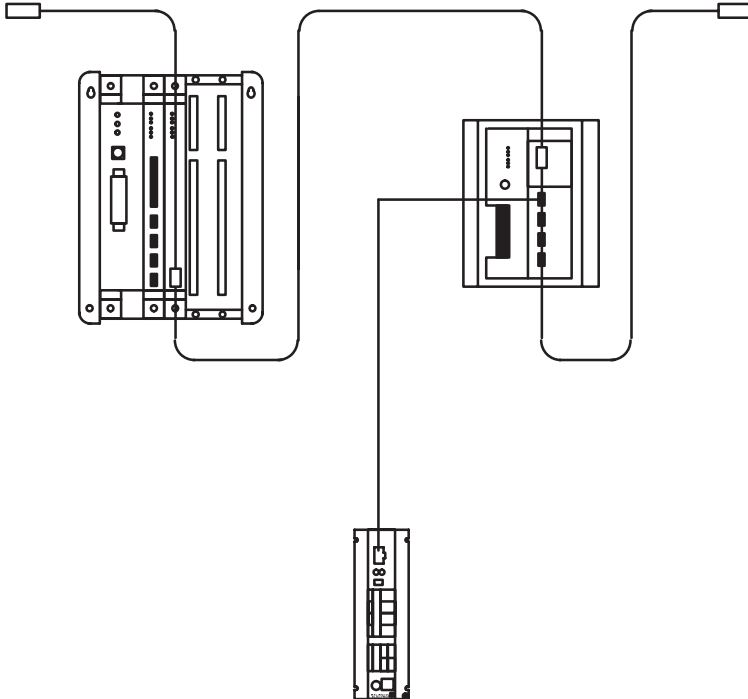

Figure 4.6- Sample Configuration for Analog Rail Module with AutoMate Remote I/O Head

4.1.2 AutoMate Programming in Rail Mode

In Rail mode, the Analog Rail module is imaged in one I/O register of the processor. Data from one of the four channels will occupy the register as a function of the channel select bits. The active channel is updated at the end of each scan. For the input channels, the two channel select bits in the register must be set to the appropriate input channel number. After the I/O update, the register contains the data in the format shown in figure 4.7.

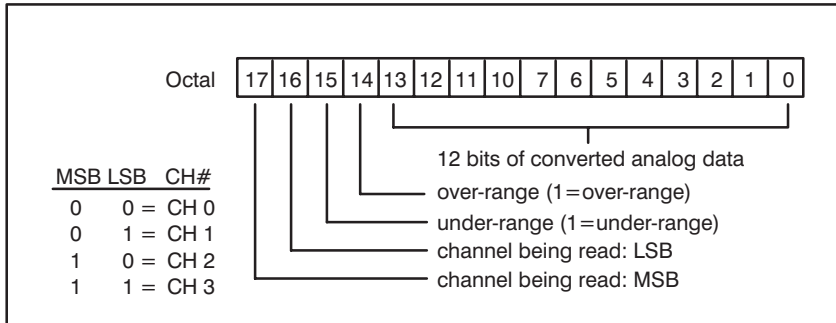

Figure 4.7 - Rail Mode Register Image for Input Channels

The Analog Rail module data may also be accessed in the middle of the scan (as opposed to the end of the scan, which is the normal mode of operation for digital rail I/O) using the appropriate number of Analog In (AIN) blocks. The AIN block will check whether the over-range or under-range bits have been set by the module and the error coil will be energized, if applicable. See section 4.1.4 for more information about the AIN block.

Note that the AIN block is supported by the AutoMate 20E M/N 45C224 and 45C225, but not the AutoMate 20 (M/N 45C20, 45C21, 45C220, 45C221) by APX Version 3.0.

For processors that do not support the AIN block, you can use the MOVE block to move data in and out of the registers assigned and to determine the channel select bits. Over-range and under-range bits should be used as inputs to error coils. The I/O update will occur automatically at the end of each scan. See Appendix C for a sample AutoMate program that reads from the Analog Rail module without using AIN blocks.

4.1.3 AutoMate Programming in Local Head Mode

In Local Head mode, the module is imaged in four I/O registers of the processor. Data from all four channels is always available and will be updated at the end of each scan. It is not necessary to select the channel. After the I/O update, the register contains the data in the format shown in figure 4.8.

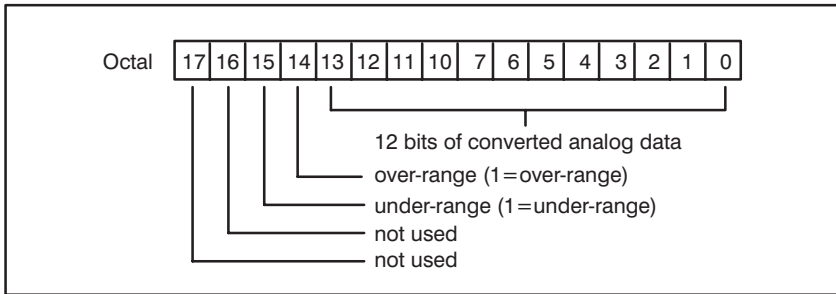

Figure 4.8 - Local Head Register Image for Input Channels

The Analog Rail module data may also be accessed in the middle of the scan (as opposed to the end of the scan) using the appropriate number of Analog In (AIN) blocks. The AIN block will set the over-range or under-range bits if applicable. See section 4.1.4 for more information about the AIN blocks.

Note that the AIN block is supported by the AutoMate 20E (M/N 45C224 and 45C225), but not the AutoMate 20 (M/N 45C20, 45C21, 45C220, 45C221) by APX Version 3.0.

For processors that do not support the AIN block, you can use the MOVE block to move data in and out of the registers assigned. Over-range and under-range bits should be used as inputs to error coils. The I/O update will occur automatically at the end of each scan. See Appendix C for a sample AutoMate program that reads from the Analog Rail module without using the AIN block.

4.1.4 Analog In (AIN) Instruction Block

The AIN block is used to read inputs from the Analog Rail module. AIN is supported for the A20E. The AIN block makes it possible to update the channels on the Analog Rail module during the scan instead of at the end of the scan (the standard AutoMate I/O update). The block also makes it possible to update all four channels during the scan in Rail mode, a hardware configuration which would otherwise allow only one channel on the module to be updated. The format of the AIN block is shown in figure 4.9.

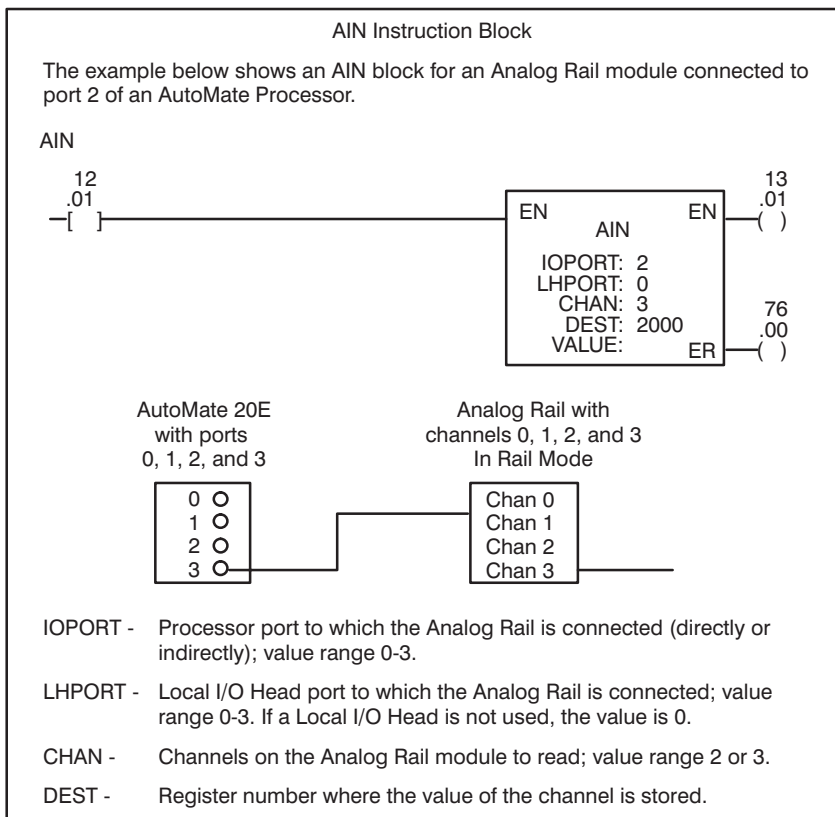

Figure 4.9 - AIN Instruction Block

4.2 Analog Rail Module in DCS 5000/AutoMax Systems

This section describes how the Analog Rail is used with DCS 5000/AutoMax systems.

4.2.1 Configuring the Analog Rail Module with a DCS 5000/AutoMax Remote I/O Head

The Analog Rail module is used in the Local Head mode when the host is a DCS 5000/AutoMax Remote I/O Head. For AutoMax Version 3.0 and later, the Analog Rail module is configured using the AutoMax Programming Executive. Refer to instruction manual J-3750 for more information. For DCS 5000 or AutoMax Version 2.1 or earlier, the module is defined in the configuration task for the master rack using the DCS 5000 or AutoMax Programming Executive software. See instruction manual J-3649 for more information on the configuration task.

For DCS 5000 or AutoMax Version 2.1 or earlier, use the RIODEF statement to define each channel on the Analog Rail module as a separate register. Note that in addition to defining each channel as a register, you can also define the over-range and under-range bits for each channel separately. These bits can also be defined using the RIODEF statement. Use the following format for the RIODEF statement:

```
nnnnn RIODEF name[MASTER_SLOT=m, DROP=d, SLOT=s, REGISTER=r, BIT=b]
```

where:

nnnnn - Configuration task line number; range 1-32767.

name - Symbolic name of channel, ending with % (integer) for registers, @ (booleans) for bits.

m - Slot in rack containing DCS 5000/AutoMax master remote I/O module; range 0-15.

d - Drop number of DCS 5000/AutoMax Remote I/O Head; range 1-7.

s - Communication port on the DCS 5000/AutoMax Remote I/O Head to which the Analog Rail module or Local I/O Head is connected; range 0-3.

r - Register number; range 0-3.

b - Optional field defining the bit position within the register number; range 0-15.

4.2.2 Configuring the Analog Rail Module with a Power Module Interface Processor Host

The Analog Rail module is used in the Rail mode when the host is a Power Module Interface (PMI) Processor. Beginning with AutoMax Version 3.3, the Analog Rail module is configured using the AutoMax Programming Executive. Refer to instruction manual J2-3045 for more information.

4.2.3 DCS 5000/AutoMax Programming

When programming the Analog Rail module, it is recommended that you monitor the state of the over-range and under-range bits for the input channels. You can check the status of the appropriate bits directly if they were defined in the configuration. You can also use the BASIC expression AND with the variable name assigned to the input channel to mask off the 12 bits of analog data and read the values in the over-range and under-range bits. Any non-zero result means that the value is out of range. See the following three statements for examples of how to detect values out of range. Use the hexadecimal values shown to mask off the analog data.

The value in the channel defined as CHANNEL_2 is either over-range or under-range:

```
10000 RANGE_ERROR@ = CHANNEL_2 AND 3000H
```

The value in the channel defined as CHANNEL_2 is over-range:

```
11000 OVER_ERROR@ = CHANNEL_2 AND 1000H
```

The value in the channel defined as CHANNEL_2 is under-range:

```
12000 UNDER_ERROR@ = CHANNEL_2 AND 2000H
```

5.0 DIAGNOSTICS AND TROUBLESHOOTING

DANGER

THE REMAINING STEPS ARE MADE WITH POWER ON. EXERCISE EXTREME CAUTION BECAUSE HAZARDOUS VOLTAGE EXISTS. FAILURE TO OBSERVE THIS PRECAUTION COULD RESULT IN SEVERE BODILY INJURY OR LOSS OF LIFE.

WARNING

ONLY QUALIFIED ELECTRICAL PERSONNEL FAMILIAR WITH THE CONSTRUCTION AND OPERATION OF THIS EQUIPMENT AND THE HAZARDS INVOLVED SHOULD INSTALL, ADJUST, OPERATE, AND/OR SERVICE THIS EQUIPMENT. READ AND UNDERSTAND THIS MANUAL IN ITS ENTIRETY BEFORE PROCEEDING. FAILURE TO OBSERVE THIS PRECAUTION COULD RESULT IN BODILY INJURY.

WARNING

INSERTING OR REMOVING THIS PRODUCT OR ITS CONNECTING CABLES MAY RESULT IN UNEXPECTED MACHINE MOTION. POWER TO THE MACHINE SHOULD BE TURNED OFF BEFORE INSERTING OR REMOVING THE PRODUCT OR ITS CONNECTING CABLES. FAILURE TO OBSERVE THIS PRECAUTION COULD RESULT IN BODILY INJURY.

This section explains how to troubleshoot the Analog Rail module. If you cannot correct the problem using the instructions below, the unit is not user-serviceable.

5.1 Both LEDs on the Faceplate are Off

Problem: The "PWR OK" and "COM OK" LEDs on the faceplate are off. This problem can indicate that the unit is not receiving the +5V from the processor or Local or Remote Head, the 120 VAC or 24 VDC from the external power supply, or both within the specified ranges. This problem can also indicate that the external power supply fuse (.75A or .25A) has blown or that the module is malfunctioning.

- Step 1. Stop any application programs or tasks that are running. Use a voltmeter to measure the input power (120 VAC or 24 VDC) to the module. Verify that the power source is providing 120 VAC or 24 VDC, whichever is appropriate.

DANGER

VOLTAGE IS PRESENT ON THE PLUG CONNECTOR TERMINALS. DISCONNECT THE POWER AT THE SOURCE BEFORE TOUCHING THE PLUG CONNECTOR TERMINALS. FAILURE TO OBSERVE THIS PRECAUTION COULD RESULT IN SEVERE BODILY INJURY OR LOSS OF LIFE.

DANGER

DO NOT TOUCH THE CONNECTORS ON THE FACEPLATE IF THERE IS POWER ON THE WIRES ATTACHED TO THE PLUG CONNECTOR SCREW TERMINALS. ALWAYS TURN OFF POWER BEFORE HANDLING A CONNECTOR THAT IS WIRED. FAILURE TO OBSERVE THIS PRECAUTION COULD RESULT IN SEVERE BODILY INJURY OR LOSS OF LIFE.

- Step 2. Turn off power to the module. Verify that the input power connector is connected securely to the faceplate. Verify that the I/O Rail cable connections are tight at both ends.
- Step 3. Turn on power to the module. If LEDs are still off, try replacing the I/O Rail cable. Check that the pins on the input connector are not bent.
- Step 4. If the LEDs are still off, turn off power to the module and replace the power supply fuse on the front panel following the directions below.

CAUTION

MAKE CERTAIN THAT THE ANALOG RAIL MODULE CONTAINS THE PROPER FUSE FOR THE POWER SUPPLY BEING USED. USE A .25 A FUSE FOR 120 VAC POWER AND A .75A FUSE FOR 24 VDC POWER. FAILURE TO OBSERVE THIS PRECAUTION COULD RESULT IN DAMAGE TO OR DESTRUCTION OF THE EQUIPMENT.

- a) Use a screwdriver to release the fuse holder located on the Analog Rail module faceplate. Pull the fuse holder out of the module.
 - b) Take the old fuse out of the fuse holder and replace it with the new fuse. Use a .25A fuse for 120 VAC power and a .75A fuse for 24 VDC power. See Appendix A for the fuse type and rating.
 - c) Re-insert the fuse holder into the module. Turn the screwdriver clockwise while pressing down on the fuse holder. The fuse holder must be flush against the faceplate.
- Step 5. Turn on power to the module. If both LEDs still do not light, replace the module.

5.2 The “COM OK” LED is Off

Problem: The “COM OK” LED on the faceplate is off. This LED signifies whether there is communication between the Analog Rail and the host. The LED should be on if communication is taking place. The possible causes of this problem are incorrect configuration, a disconnected or malfunctioning I/O Rail cable, a malfunctioning host, or a malfunctioning Analog Rail module. After verifying that the configuration of the Analog Rail is correct, follow the steps below to isolate the problem.

- Step 1. Stop any application tasks or programs that are running and turn off power to the Analog Rail module.

DANGER

VOLTAGE IS PRESENT ON THE PLUG CONNECTOR TERMINALS. DISCONNECT THE POWER AT THE SOURCE BEFORE TOUCHING THE PLUG CONNECTOR TERMINALS. FAILURE TO OBSERVE THIS PRECAUTION COULD RESULT IN SEVERE BODILY INJURY OR LOSS OF LIFE.

DANGER

DO NOT TOUCH THE CONNECTORS ON THE FACEPLATE IF THERE IS POWER ON THE WIRES ATTACHED TO THE PLUG CONNECTOR SCREW TERMINALS. ALWAYS TURN OFF POWER BEFORE HANDLING A CONNECTOR THAT IS WIRED. FAILURE TO OBSERVE THIS PRECAUTION COULD RESULT IN SEVERE BODILY INJURY OF LOSS OF LIFE.

- Step 2. Verify that the connections on both ends of the I/O Rail cable are tight. Check that the pins on the input connector are not bent.
- Step 3. Turn on power to the module. The “COM OK” LED should be illuminated if communication is taking place. If the LED still does not illuminate, turn off power to the module and replace the I/O Rail cable.
- Step 4. If applicable, try to reset the condition by disconnecting and then re-connecting the cable between the host and the Local I/O Head, the AutoMate Remote I/O Head, or the DCS 5000/AutoMax Remote I/O Head. Troubleshoot the host if necessary. If the problem is still not corrected, replace the Analog Rail module.

5.3 Incorrect Data

Problem: The data (signal) being read is always on, always off, or different than expected. The possible causes of this problem are incorrect configuration, a programming error, a disconnected or malfunctioning I/O Rail cable, disconnected or malfunctioning wiring to the external hardware, malfunctioning external hardware or a malfunctioning Analog Rail module. After verifying that the configuration of the module is correct, follow the steps below to isolate the problem.

- Step 1. Verify that the application program(s) is correct. Check to see that the program is referencing the correct registers (AutoMate) or symbolic names (DCS 5000/AutoMax). In DCS 5000/AutoMax applications, make certain that the program is not attempting to write to the input channels.
- Step 2. Stop any application tasks that are running. Turn off power to the Analog Rail module.
- Step 3. Try to clear the condition by disconnecting and then reconnecting the I/O Rail cable. Make certain the connections are tight. If applicable, check the connections between the host and the Local I/O Head, the AutoMate Remote I/O Head, or the DCS 5000/AutoMax Remote I/O Head. Check that the pins on the input connector are not bent.
- Step 4. Turn off power to the external hardware. Verify that the wiring to the external hardware is tight and functioning correctly.
- Step 5. Turn on power to the external hardware.
For input channels, use the Executive software to read the value on the input channels. Use an ammeter to read the input signal and compare the two. If the signal is being converted correctly, there is a problem with the external hardware or wiring.
- Step 6. Troubleshoot the external hardware, the wiring, and the host.

5.4 Constant Under-Range

Problem: the under-range bit (12 decimal) on an input channel register is constantly set to 1. Assuming that the power supply for the external hardware connected to the input channel is providing an input signal within the specified limits (4-20mA), the possible causes of this problem are a loose connector on the analog input section of the faceplate, loose or malfunctioning wiring, incorrect (reversed) input signal wiring on the module faceplate, or a blown input channel fuse (32mA fuse). Follow the steps below to isolate the problem.

- Step 1. Stop any application tasks that are running. Turn off power to the external hardware connected to the module. Turn off input power (120 VAC or 24 VDC) to the module.
- Step 2. Verify that the 12-point connector on the analog section of the module faceplate is securely attached to its mating half.
- Step 3. Verify that the signal wiring on the module faceplate is correct. See step 9 in section 3.2 for more information. Verify that the wiring is tight and functioning properly.
- Step 4. Turn on power to the module and to the external hardware. Use the Executive software to read the value on the input channel. Use an ammeter to read the input signals at the terminal point and compare the two. If both read zero, verify that the external hardware is operating correctly. If the external hardware is operating correctly, the 32mA fuse for the input channel may be blown.

- Step 5. Replace the 32mA fuse(s) that has blown following the directions below.
- a) Stop any application tasks that are running.
 - b) Turn off power to the external hardware connected to the module. Turn off power (120 VAC or 24 VDC) to the module.
 - c) Without disconnecting the wiring, remove the 12-point connector from the faceplate and set aside. Without disconnecting the wiring, remove the 4-point connector from the faceplate and set aside.
 - d) Before disassembling the module, note that it consists of two major pieces, the metal enclosure and the printed circuit board, which is screwed to the left side of the enclosure (if facing the front of the module). After the screws are removed, the two pieces can be separated in a manner similar to that of opening a book. Simply pull the left side of the module (including the faceplate) to the left away from the remainder of the metal enclosure. See below for the screws that need to be removed. If some of the screws are inaccessible, remove the entire module from the cabinet before proceeding.

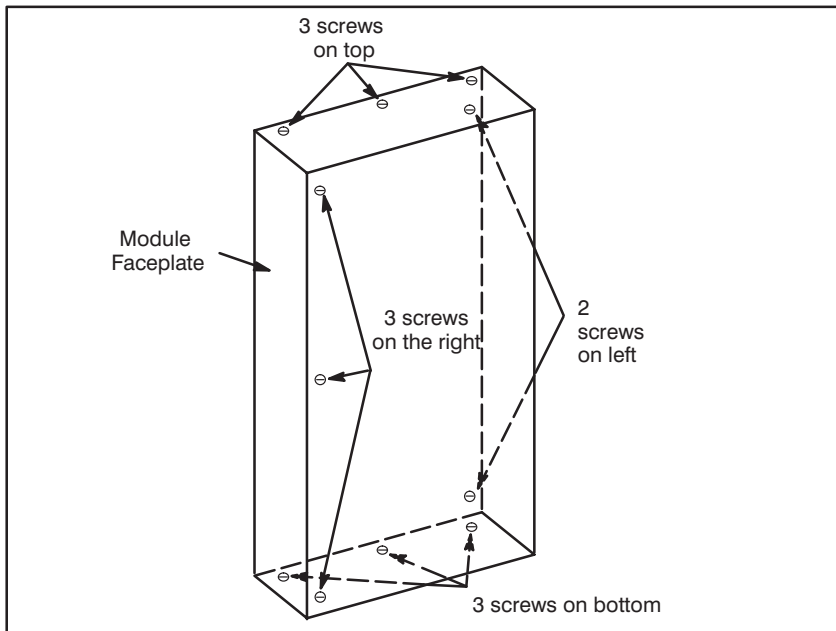

Figure 5.1 - Disassembling the Module to Replace the 32mA Fuse

- e) Place the metal enclosure side of the left-hand piece on a clean surface. Note the position of the fuses from the drawing below. As shown on the drawing, the top fuse is for channel 0 and the bottom fuse is for channel 3. The fuses are held in place by spring clips and are marked F1, F2, F3 and F4. Remove the blown fuse(s) carefully and discard. Replace the fuse(s) with a new fuse.

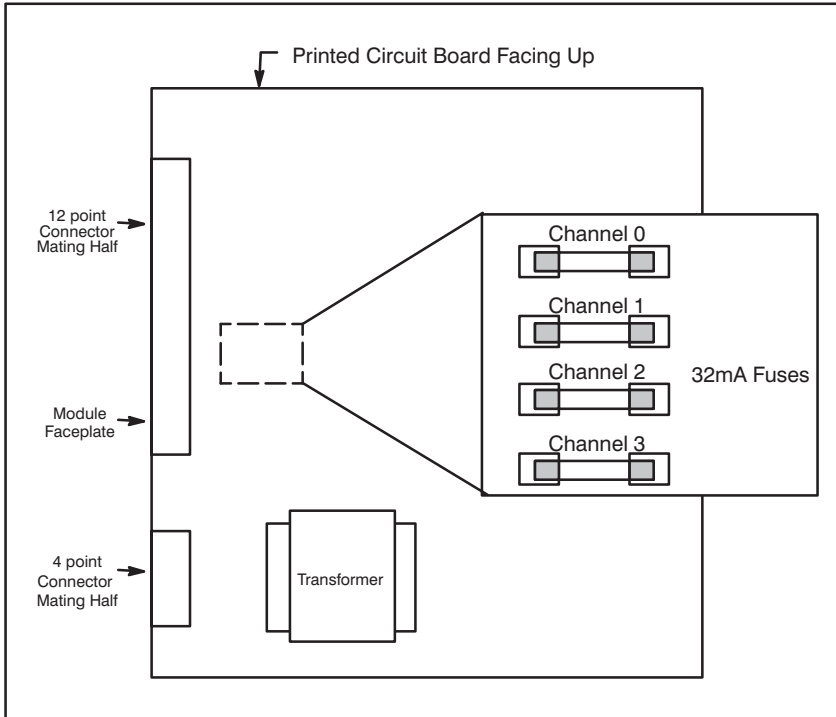

Figure 5.2 - Replacing the 32mA Fuse

- f) Using the reserved screws, re-attach the printed circuit board assembly to the metal enclosure, making certain that the lip on the metal enclosure is covered by the printed circuit board assembly. If the module is re-assembled incorrectly, the screw holes will not line up properly.
- g) Re-attach the two connectors to the faceplate of the module. Turn on power to the module. Turn on power to the external hardware.

Appendix A

Technical Specifications

Ambient Conditions

- Storage temperature: -40°C to 85°C
 -40°F to 185°F
- Operating temperature (at the module): 0°C to 60°C
 32°F to 140°F
- Humidity: 5-90% non-condensing

Dimensions

- Height: 9.25 inches (23.5 cm)
- Width: 2.94 inches (7.5 cm)
- Depth: 7.75 inches (19.7 cm including plug-in terminals)
- Weight: 4.5 lbs (2.1 kg)

Recommended Cable for Analog Signal Wiring

- Belden 8761 or equivalent type

Maximum Power Dissipation

- 4.5 Watts

Communication Power Requirements

- +5V: 250 mA (supplied by host through I/O Rail cable)

Analog Circuit Power Supply

(use either 120 VAC or 24 VDC supply)

- 120 VAC supply: 92 - 132V acceptable range (+15% / -20%)
Maximum current: 150 mA
- 24 VDC supply: 20 - 32V acceptable range (+33% / -16%)
Maximum current: 350 mA

Maximum Source KVA

- 10

Fuse Types and Rating

- MDQ 250 VAC .25A (for 120 VAC power)
- MDQ 250 VAC .75A (for 24 VDC power)
- GDB 250 VAC .032A (for analog signal inputs)

Appendix A

(Continued)

Input Channels

- Operating range: 4-20 mA
- Number of channels: 4 (single-ended)
- Number of commons: 1 (shared among all 4 channels)
- Resolution: 12 bits binary
- Non-linearity: ± 1 LSB maximum
- Accuracy: $\pm 0.33\%$ of full scale at 25°C maximum
- Thermal drift: ± 50 ppm/degrees C
- Type of converter: Successive approximation
- Speed of conversion: 13 usec
- Impedance: 278 Ohms plus 32 mA fuse resistance
(an additional 200-400 Ohms)
- Input filter: 2nd order 160 Hz low pass
- Input over-current protection: 32 mA fuse per input channel
- Isolation of analog section from host and input power: 2500V RMS

Appendix B

Block Diagram

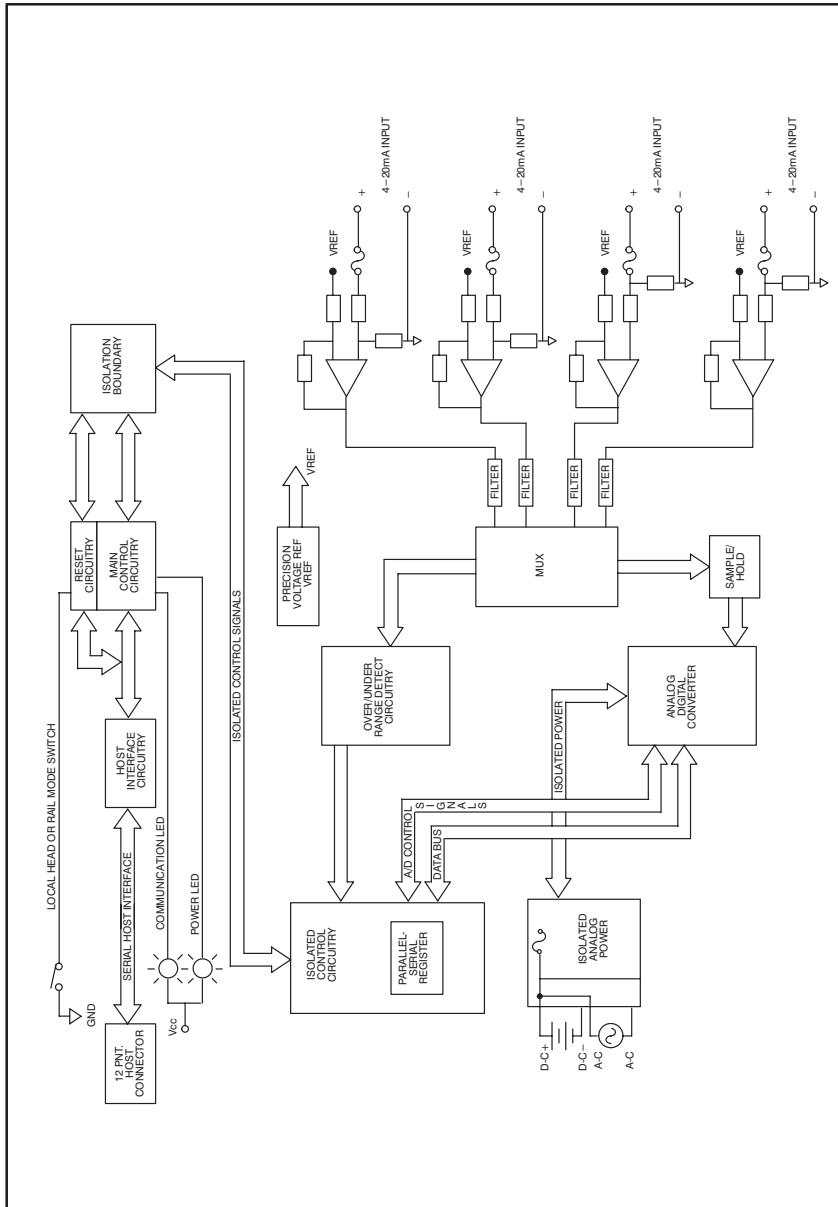

Appendix C

Sample AutoMate Program

The following AutoMate program sequences can be used to interface to an AutoMate Processor that does not support the AIN block. Over a period of four scans, the program below inputs four channels from an Analog Rail module in Rail mode.

Registers Used

0	Register that is configured to be updated at the end of scan.
40	Value input from channel 0
41	Value input from channel 1
42	Value input from channel 2
43	Value input from channel 3
44	Counter to select channel to operate this scan
45	Coils

Beginning of the Scan

If channel 0 was read in, put the data in register 40. The channel select bits are cleared, but the under-range and over-range bits are left for later testing.

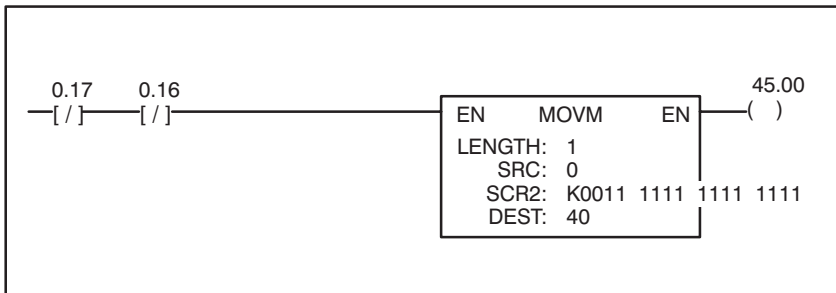

If channel 1 was read in, put the data in register 41.

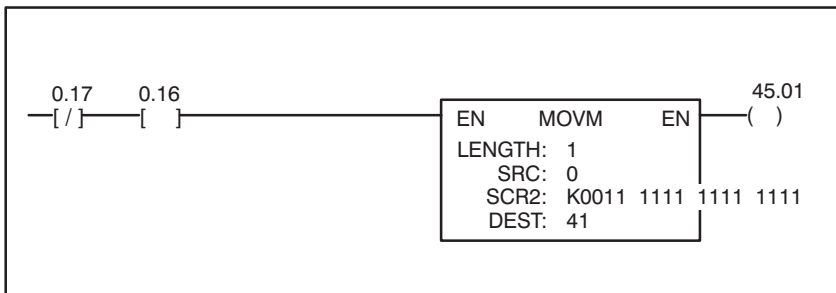

Appendix C

(Continued)

If channel 2 was read in, put the data in register 42.

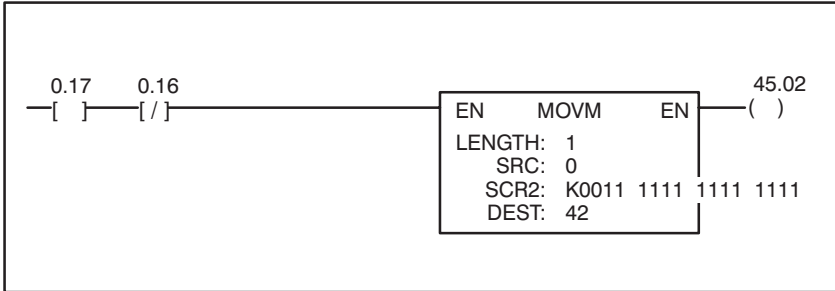

If channel 3 was read in, put the data in register 43.

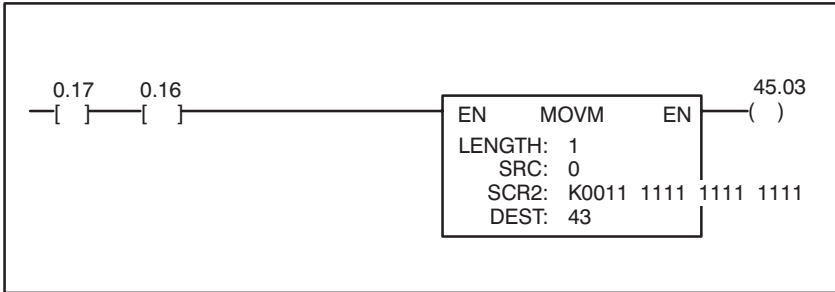

At the End of the Scan

Select the channel to read in at end of scan.

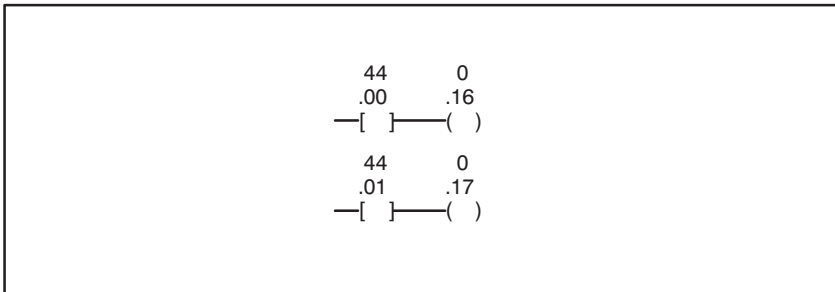

Appendix C

(Continued)

Increment counter 0, 1, 2, 3 and then back to 0.

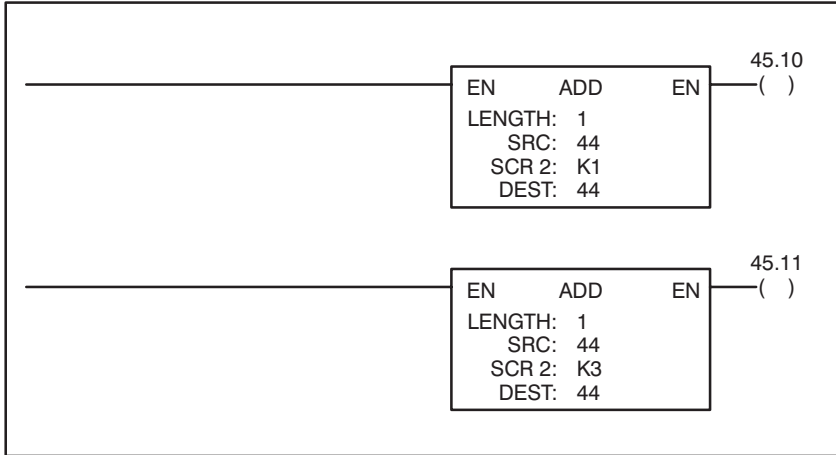

For additional information

1 Allen-Bradley Drive
Mayfield Heights, Ohio 44124 USA
Tel: (800) 241-2886 or (440) 646-3599
<http://www.reliance.com/automax>

www.rockwellautomation.com

Corporate Headquarters

Rockwell Automation, 777 East Wisconsin Avenue, Suite 1400, Milwaukee, WI, 53202-5302 USA, Tel: (1) 414,212,5200, Fax: (1) 414,212,5201

Headquarters for Allen-Bradley Products, Rockwell Software Products and Global Manufacturing Solutions

Americas: Rockwell Automation, 1201 South Second Street, Milwaukee, WI 53204-2496 USA, Tel: (1) 414,382,2000, Fax: (1) 414,382,4444
Europe/Middle East/Africa: Rockwell Automation SA/NV, Vorstlaan/Boulevard du Souverain 36, 1170 Brussels, Belgium, Tel: (32) 2 663 0600, Fax: (32) 2 663 0640
Asia Pacific: Rockwell Automation, 27/F Citicorp Centre, 18 Whitfield Road, Causeway Bay, Hong Kong, Tel: (852) 2887 4788, Fax: (852) 2508 1846

Headquarters for Dodge and Reliance Electric Products

Americas: Rockwell Automation, 6040 Ponders Court, Greenville, SC 29615-4617 USA, Tel: (1) 864,297,4800, Fax: (1) 864,281,2433
Europe/Middle East/Africa: Rockwell Automation, Brühlstraße 22, D-74834 Eltetal-Dallau, Germany, Tel: (49) 6261 9410, Fax: (49) 6261 17741
Asia Pacific: Rockwell Automation, 55 Newton Road, #11-01/02 Revenue House, Singapore 307987, Tel: (65) 6356-9077, Fax: (65) 6356-9011